

RIGHORN

Denali 1000 B ***Denali 1000 APEX*** ***SERVICE MANUAL***



This manual is general version, the pictures in manual book are little difference compared with real part, so please check real part accordingly.

Foreword

This manual contains such content as introductions on overhaul, maintenance, overhauling program, dismantling, assembling, troubleshooting and service data of UTV1000.

This manual will help you know the vehicle better so that you can assure your customers of fast and reliable service.

This manual has been prepared on the basis of the latest specifications at the time of publication. If modifications have been made since then, differences may exist between the content of this manual and the actual vehicle.

Illustrations in this manual are used to show the basic principles of operation and work procedures. They may not represent the actual vehicle exactly in detail.

Manufacturer reserves the right of no prior notice on product improvement or modification. Repair and maintenance shall be carried out according to actual situation of vehicle.

▲ WARNING

Inexperienced mechanics or mechanics without the proper tools and equipment may not be able to properly perform the services described in this manual.

Improper repair may result in injury to the mechanic and may render the vehicle unsafe for the rider.

Covered Models

UTV1000-15 Denali 1000 B, UTV1000-15 Denali 1000 APEX

GROUP INDEX	
GENERAL INFORMATION	1
PERIODIC MAINTENANCE	2
ENGINE	3
COOLING SYSTEM	4
FUEL SYSTEM	5
DRIVE TRAIN	6
STEERING SYSTEM	7
SUSPENSION SYSTEM	8
BRAKES SYSTEM	9
CHASSIS	10
HVAC SYSTEM	11
ELECTRICAL SYSTEM	12
TROUBLESHOOTING	13
SPECIFICATIONS	14

1.GENERAL INFORMATION

VEHICLE APPEARANCE.....	1-1	MARKER INFORMATIVENESS.....	1-2
PRECAUTIONS.....	1-2	Engine Brake-in Steps.....	1-3
TIGHTENING TORQUE.....	1-3		

1.1 VEHICLE APPEARANCE

UTV1000 left-hand view

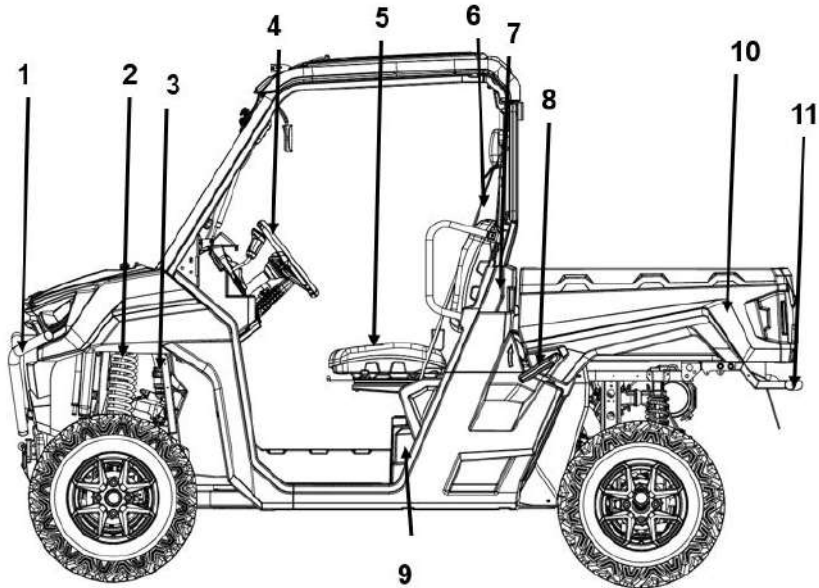

1. Front bumper	2. Front shock absorber	3. Brake fluid reservoir	4. Steering wheel
5. Driver seat	6. Driver seat belt	7. Air filter	8. Cargo box release lever
9. Battery	10. Cargo box	11. Rear bumper	

UTV 1000 right-hand view

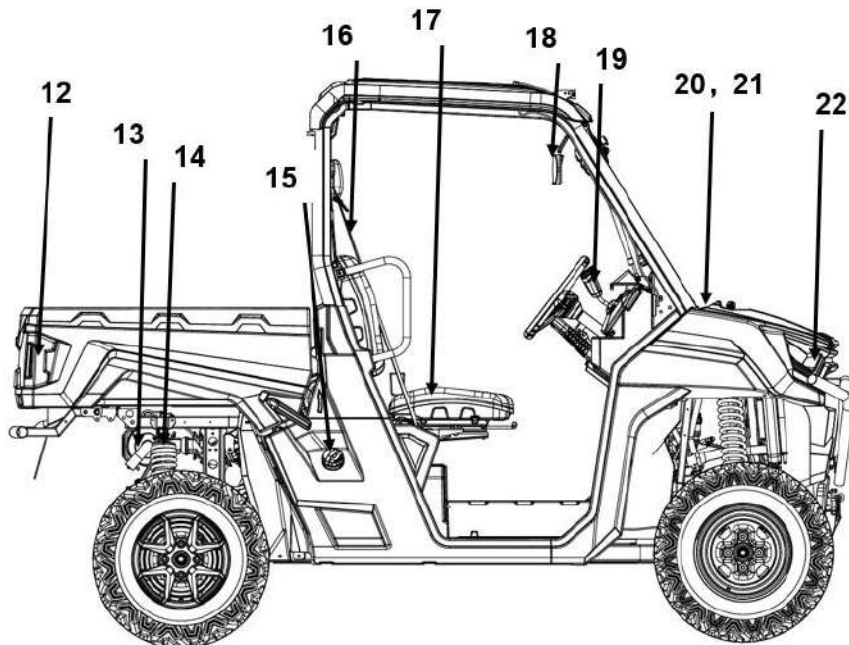

12 Tail light	13. Muffler	14. Rear absorber shock	15. Fuel tank cap
16. Passenger seat belt	17. Passenger seat	18. Inner mirror	19. Shift lever
20. Windshield washer Passenger	21. Coolant reservoir	22. Headlights	

1.2 MARKER INFORMATIVENESS

Numbers of frame (or VIN code), engine and transmission case are major information numbers of a motorcycle. When ordering components or authorizing special services, these numbers are able to assist distributors to serve you better.

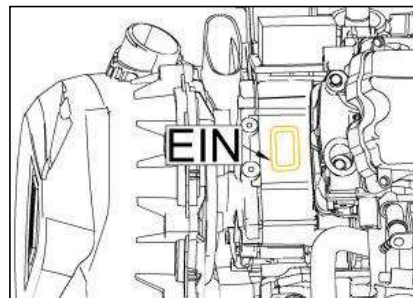
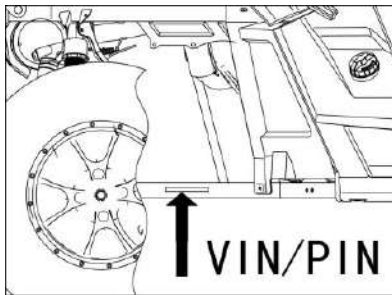
**TYPICAL**

1. EIN (Engine Identification Number on left side/anterior portion on the crankcase)
2. VIN /PIN (Vehicle Identification Number on the right side/rear on the frame)

1.3 PRECAUTIONS

1. Do not make engine under operation at a closed place or place with poor ventilation for a long time.
2. If engine stops operation, please do not touch it or silencer to avoid burning.
3. Due to high corrosiveness, battery fluid (dilute sulphuric acid) may cause burns to skin and eyes. In case of splashing it to skin, please clean it with water and contact the doctor immediately. In case of splashing it to clothes, please wash it with water immediately. Keep battery fluid far away from Children.
4. Cooling liquid is toxic. Do not drink it or splash it to skin, eyes and clothes. once splashing it to skin, please wash it with a lot of soapy water. In case of splashing it to eyes, please wash eyes immediately and contact the doctor. In case of drinking cooling liquid, resulting in vomit, please contact the doctor. Keep cooling liquid far away from children.
5. Wear proper working suit, boots and hat. If necessary, please wear long-sleeve working suit and gloves for operation.
6. Gasoline is highly inflammable. No smoking or firing. At the same time, fire sparks shall be avoided. Vaporized gasoline is explosive as well. Operation shall be carried out at places with good ventilation.
7. Battery may produce explosive hydrogen in charging. Please ensure charging at places with good ventilation.
8. Use legal parts, lubricating oil and lubricating grease.
9. Before overhauling, please clean soil and dust.
10. Keep accessories of each part well for correct assembly.
11. Replace dismantled gasket, O-shaped ring, piston pin retainer and cotter pin.
12. Retainer of rubber ring may be deformed after dismantling. So, please do not use loose and soft retainer.
13. Please wash and dry dismantled parts. Use lubricant on the surface of moving parts. For correct installation, please measure data well in dismantling process.
14. If do not know length of screw, please install screws one by one to ensure their corresponding depth.
15. Pre-tighten bolts and nuts and then tighten them with designated torque from the big to the small and from the inside to the outside.
16. Check whether rubber parts are aged. If necessary, replace them. Keep rubber parts far away from grease.

- 17.If necessary, special tools can be used.
- 18.Rotate inside and outside races of bearing to ensure flexibility of balls.
- A)If axial or radial resistance is too large, please replace it. If there is concave-convex on the surface, please use oil for washing. If no effect is achieved with washing, please replace it.
- B)If bearing cannot be clamped tightly in pressing into machine or axle, please replace bearing.
- 19.Please install a side dust proof bearing at correct direction. In installation of open or double-face dust proof bearing, pay attention to that marks of manufacturer shall be outward.
- 20.In cleaning and drying bearing, please keep bearing support still. Before installation, please carry out lubrication with oil or lubricating oil.
- 21.Please correct install elastic retaining ring. Assembling after opening can ensure installation of snap ring into slot.
- 22.After assembly, please check whether all parts are of perfect tightening and flexible movement.
- 23.Brake fluid and coolant may damage shell and plastic and rubber parts. In case of being splashed by them, please use water for washing.
- 24.In installing pipeline, please insert them to bottom of connecting pipeline. In installing pipe clamp, please install them to groove if there is. As for pipeline or pipe clamp that cannot be tightened, please replace them.
- 25.Do not mix soil or dust into engine and/or hydraulic braking system.
- 26.Before installation, please clean gasket and spacer of engine shell. Use oil stone to polish scratch of joint face evenly.
- 27.Do not twist or bend too much cable. Twisted or damaged cables may cause inflexible operation.
- 28.In assembling protective caps of parts, insert cap into groove if any.

1.4 Engine brake-in steps

Though quality material has been used for motorcycle manufacturing and all components are conforming to high quality standard, all components and parts shall subject to brake-in process before engine reaching maximum load. The reason behind this is that cooperation of components has not reached the best status after their assembling. This leads to damping force of engine and unnecessary mechanical loss. The ideal cooperation can be reached after operation for some time. In this case, mechanical loss can be minimized, reaching the best status and bringing the output power to maximum value. As a result, engine performance directly relates to initial maintenance. Regulation of running-in process is shown as follows:

-Please follow the restriction requirements for engine speed in the brake-in period below:

The first 150km	Below 5000 rpm
Till 800km	Below 5500 rpm
Till 1600km	Below 6500 rpm
Above 1600km	Below 8500 rpm

-Do not fully open the accelerator before the reading of the odometer reaching 1000km.

Attention: the speed shall not exceed 6500 rpm no matter what in brake-in period.

-During the brake-in period, the engine shall not work at the same speed with the same gear position for a long time. Try to shift gear position and speed to facility running-in of components.

-After 1000km of operation, transmission and crank cases shall be cleaned thoroughly.

1.5 TIGHTENING TORQUE

Locking devices (e.g.: locking tabs, elastic stop nuts, self-locking fasteners, etc.) must be installed or replaced with new ones, where specified. If the efficiency of a locking device is impaired, it must be renewed. In order to avoid a poor assembling, tighten screws, bolts or nuts in accordance with the following recommended torque value:

Grade	Torque (N·m)					
	M6	M8	M10	M12	M14	M16
4.6	4~5	10~12	20~25	36~45	55~70	90~110
5.6	5~7	12~15	25~32	45~55	70~90	110~140
6.8	7~9	17~23	33~45	58~78	93~124	145~193
8.8	9~12	22~30	45~59	78~104	124~165	193~257
10.9	13~16	30~36	65~78	110~130	180~201	280~330
12.9	16~21	38~51	75~100	131~175	209~278	326~434

Grade	Torque (lbf.ft)					
	M6	M8	M10	M12	M14	M16
4.6	3~3.7	7.4~8.6	14.8~18.5	26.6~33.2	40.6~51.7	66.4~81.2
5.6	3.7~5.2	8.9~11.1	18.5~23.6	33.2~40.6	51.7~66.4	81.2~103.3
6.8	5.2~6.6	12.5~17	24.4~33.2	42.8~57.6	68.6~91.5	107~142.4
8.8	6.6~8.6	16.2~22.1	33.2~43.5	57.6~76.8	91.5~121.8	142.4~189.7
10.9	9.6~11.8	22.1~26.6	48~57.6	81.2~95.9	132.8~148.3	206.6~243.5
12.9	11.8~15.5	28~37.6	55.4~73.8	96.7~129.2	154.2~205.2	240.6~320.3

CAUTION: Be sure to use the proper tightening torque for the proper strength grade. Always torque screws, bolts and / or nuts in a crisscross sequence.

	Bolt length comparison table							
Length(mm)	12	14	16	20	25	30	35	40
Length(in)	0.47	0.55	0.63	0.79	0.98	1.18	1.38	1.57
Length(mm)	45	50	55	60	65	70	75	80
Length(in)	1.77	1.97	2.17	2.36	2.56	2.76	2.95	3.15
Length(mm)	85	90	95	100	105	110	115	120
Length(in)	3.35	3.54	3.74	3.94	4.13	4.33	4.53	4.72
Length(mm)	125	130	135	140	145	150	155	160
Length(in)	4.92	5.12	5.31	5.51	5.71	5.91	6.1	6.3
Length(mm)	165	170	175	180	185	190	195	200
Length(in)	6.5	6.69	6.89	7.09	7.28	7.48	7.68	7.8

2. PERIODIC MAINTENANCE

MAINTENANCE SCHEDULE.....	2-1	AIR CLEANER.....	2-2
VALVE CLEARANCE.....	2-3	SPARK PLUG.....	2-4
THROTTLE CABLE PLAY.....	2-5	ENGINE OIL.....	2-5
FRONT DIFFERENTIAL OIL.....	2-6	STEERING SYSTEM.....	2-7
BRAKING SYSTEM.....	2-7	GEAR SHIFT.....	2-7
COOLING SYSTEM.....	2-8	WHEELS.....	2-8
ENGINE COMPRESSION PRESSURE.....	2-9	ENGINE OIL PRESSURE.....	2-9
SUSPENSION SYSTEM.....	2-9		

2.1 MAINTENANCE SCHEDULE

In order to maintain the best performance and economical performance of vehicles, suggestions on intervals for necessary regular maintenance are listed. Following maintenance is calculated in km, mile and hour based on firstly appeared data.

However, keep in mind that if the vehicle isn't used for a long period of time, the month maintenance intervals should be followed.

Items marked with an asterisk should be performed by a dealer as they require special tools and technical skills.

In case of complicated road conditions, regular maintenance shall be carried for vehicles.

ITEM	ROUTINE	Whichever Comes first ⇒	INITIAL			EVERY		
			month	1	3	6	6	12
			Km (mi)	320 (200)	1200 (750)	2400 (1500)	2400 (1500)	4800 (3000)
			hours	20	75	150	150	300
Valves*	<ul style="list-style-type: none"> ● Check valve clearance. ● Adjust if necessary. 		○		○	○	○	
Cooling system	<ul style="list-style-type: none"> ● Check coolant leakage. ● Repair if necessary. ● Replace coolant every 24 months. 		○	○	○	○	○	
Spark plug	<ul style="list-style-type: none"> ● Check condition. ● Adjust gap and clean. ● Replacement every 24 months 		○	○	○	○	○	
Air filter elements	<ul style="list-style-type: none"> ● Clean. ● Replacement every 24 months 	Every 20-40 hours (More often in dusty areas)						
Crankcase breather system*	<ul style="list-style-type: none"> ● Check breather hose for cracks or damage. ● Replace if necessary. 				○	○	○	
Exhaust system*	<ul style="list-style-type: none"> ● Check for leakage. ● Tighten if necessary. ● Replace gasket(s) if necessary. 				○	○	○	
Fuel line*	<ul style="list-style-type: none"> ● Check fuel hose for cracks or damage. ● Replacement fuel hoses every 48 months ● Replacement fuel filters every 24 months 				○	○	○	
Engine oil	<ul style="list-style-type: none"> ● Replace (Check oil level every month). 		○		○	○	○	
Engine oil filter	<ul style="list-style-type: none"> ● Replace. 		○		○		○	
Differential and gearbox oil	<ul style="list-style-type: none"> ● Check oil level/oil leakage. ● Replacement every 24 months. 		○				○	
Brake*	<ul style="list-style-type: none"> ● Check operation/brake pad wear/fluid leakage. ● Brake fluid needs to be above the lowest position. ● Correct if necessary. Replace pads/disk if worn to the limit. 		○	○	○	○	○	
Accelerator pedal*	<ul style="list-style-type: none"> ● Check operation and free play. 		○	○	○	○	○	
Wheels*	<ul style="list-style-type: none"> ● Check balance/damage/ run out ● Repair if necessary. 		○		○	○	○	
Wheel bearings*	<ul style="list-style-type: none"> ● Check bearing assemblies for looseness or damage. ● Replace if damaged. 		○		○	○	○	
Front and rear Suspension*	<ul style="list-style-type: none"> ● Check no deformation and looseness. ● Correct if necessary. 				○		○	

Steering system*	<ul style="list-style-type: none"> ●Check operation and no looseness. ●Repair if damage. ●Check toe-in/Adjust if necessary. 	O	O	O	O	O
Rear knuckle pivots and suspension arms*	<ul style="list-style-type: none"> ●Lubricate with lithium-soap-based grease. 			O	O	O
Drive shaft universal joint*	<ul style="list-style-type: none"> ●Lubricate with lithium-soap-based grease. 			O	O	O
Engine mount*	<ul style="list-style-type: none"> ●Check for cracks or damage. ●Correct bolt tightness. 			O	O	O
Front and rear axle boots*	<ul style="list-style-type: none"> ●Check operation. ●Replace if damage. 	O				O
Stabilizer bushings*	<ul style="list-style-type: none"> ●Check for cracks or damage. 			O	O	O
Fittings and fasteners*	<ul style="list-style-type: none"> ●Check all chassis fittings and fasteners. ●Correct if necessary. 	O	O	O	O	O
Battery	<ul style="list-style-type: none"> ●End connection 	O		O	O	O
Lamp and steering indication	<ul style="list-style-type: none"> ●Operation 	O	O	O	O	O

2.2 AIR CLEANER

In case of driving in dusty environment, air filter shall be cleaned regularly. It is of great possibility to accelerate wear to engine if there is not filtering element or worn filtering element is used. So, please keep air filter under good conditions all the time. If vehicle is used in dusty area, inspect more frequently than specified in MAINTENANCE SCHEDULE.

If the air cleaner is clogged with dust, intake resistance will be increased, with a resultant decrease in power output and an increase in fuel consumption. never remove or modify any component in the air filter housing. The engine management system is calibrated to operate specifically with these components. Otherwise, engine performance degradation or damage can occur.

CVT Air Filter

Removal

Tilt cargo box, remove air filter protective cover. Pull CVT air filter out.

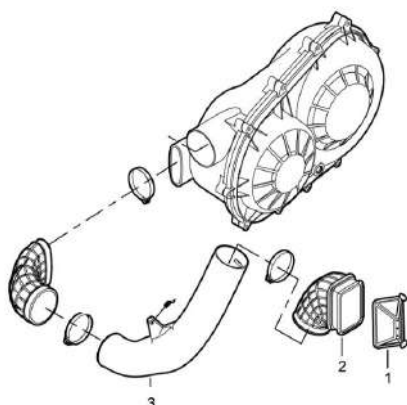

- 1. CVT air filter
- 2. CVT air intake boot
- 3. CVT intake pipe

Cleaning

- 1. Inspect filter and replace if damaged.
- 2. Clean filter, using soft soap and water, then water rinse.
- 3. Gently shake off excess water and allow filter to

dry at room temperature.

- 4. Clean the inside of CVT air inlet with a vacuum cleaner.

CVT Air Filter Installation

Reinstall CVT air filter and lower cargo box.

NOTE: Maintaining a clean CVT air filter will maximize air flow for an optimum CVT components lifespan.

Engine Air Filter

Engine Air Filter Removal

Tilt cargo box.

Unlatch air filter cover and remove air filter.

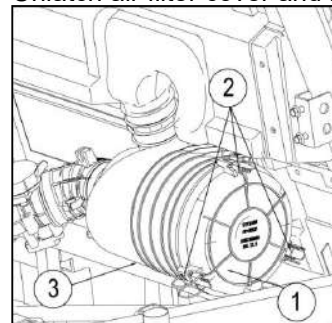

RH SIDE OF VEHICLE, UNDER CARGO BOX

- 1. Air filter cover
- 2. Latches
- 3. Duck bill valve

The filter fits tightly over the outlet tube and there will be some initial resistance.

Gently move the end of the filter back and forth to break the seal, then rotate while pulling straight out. Avoid knocking the filter against the vehicle.

Engine Air Filter Cleaning

-Inspect the filter for any signs of leaks. A streak of dust on the clean side of the filter is a telltale sign. Replace filter if there are any damages. Eliminate any source of air leaks before installing a new filter.

-Clean engine air filter by tapping out heavy dust from paper element, this will allow dirt and dust to get out of the paper filter.

NOTICE: It is not recommended to blow compressed air on the paper element; this could damage the paper fibers and reduce its filtration ability when used in dusty environments. If engine

air filter is too dirty and cannot be cleaned following the recommended procedure, it should be replaced. -Use a clean damp cloth to wipe both the filter sealing surface and the inside of the outlet tube. Ensure that the outlet tube sealing area is undamaged. Inspect air filter housing for cleanliness.

Duckbill Valve Cleaning

Visually check and physically squeeze the duckbill valve. Make sure that the valve is flexible and not inverted, damaged or plugged.

Engine Air Filter Installation

Insert the filter carefully. Seat the filter by hand, making certain it is inserted completely into the air cleaner housing. Apply pressure by hand at the outer rim of the filter, not the flexible center. Secure air filter cover with latches.

HV/HVAC System Air Filter(If equipped)

Notice: The cleaning of the filter must be performed more often than recommended when riding in dusty conditions or sand.

Removal

Remove front panel.

Remove A/C intake grille.

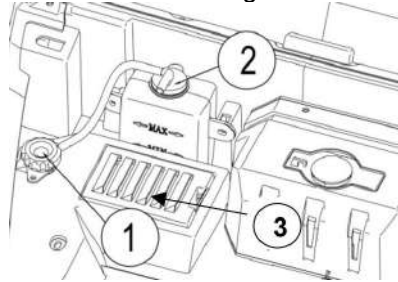

- 1. Radiator cap
- 2. Auxiliary water tank
- 3. Heater air filter

Pull out heater air filter from A/C intake duct.

Insection and Cleaning

Inspect the filter for any signs of leaks. A streak of dust on the clean side of the filter is a telltale sign. Replace filter if there are any damages. Eliminate any source of air leaks before installing a new filter. Clean air filter by tapping out heavy dust from paper element, this will allow dirt and dust to get out of the paper filter.

NOTICE: It is not recommended to blow compressed air on the paper element; this could damage the paper fibers and reduce its filtration ability when used in dusty environments. If air filter is too dirty and cannot be cleaned following the recommended procedure, it should be replaced.

Use a clean damp cloth to wipe both the filter sealing surface and the inside of the intake pipe. Ensure that intake pipe sealing area is undamaged.

Installation

The installation is the reverser of the removal procedure.

2.3 VALVE CLEARANCE

Excessive valve clearance results in valve noise and insufficient valve clearance results in valve damage and reduced power.

Check the intake and exhaust valve clearances at the distances indicated above and adjust the valve clearances to specification, if necessary.

Valve clearance is to be checked when the engine is cold. The intake and exhaust valve must be checked an adjusted when the piston is at TOP DEAD CENTER(TDC) on the compression stroke.

Tilt cargo box.

Remove relevant accessories around an engine, with relevant contents referring to Chapter 5 Vehicle Dismantling.

Remove spark plug cable and spark plug of both cylinders.

Remove the compressor form engine.(Only for HVAC Version)

Remove the bolts and valve cover of both cylinders.

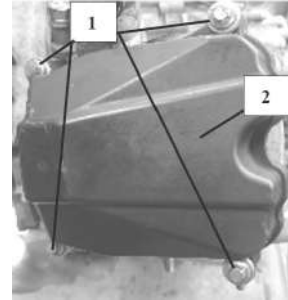

TYPICAL

- 1.4xM6 bolt
- 2. Valve cover

Remove the M6 bolts, the magneto cover and crankshaft position sensor.

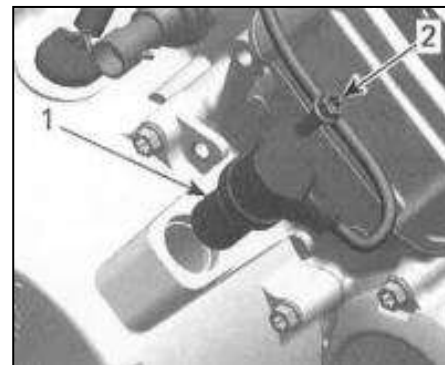

TYPICAL

- 1. Crankshaft position sensor
- 2. M6 bolt

Valve clearance of cylinder 2

Use a 13 mm socket to turn crankshaft until piston 2, rear is at TDC ignition.

When rear piston is at TDC ignition, marks on magneto flywheel "2" and on the magneto cover are aligned.

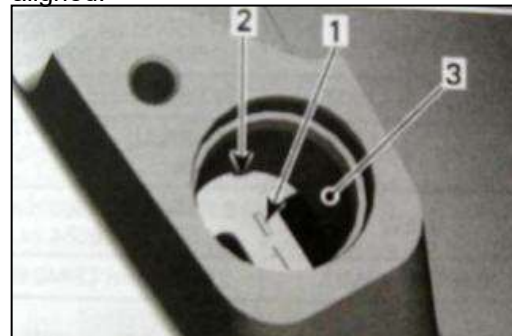

- 1. Mark "2" on magneto flywheel
- 2. Notch on magneto cover
- 3. Location of crankshaft position sensor

At TDC ignition, the printed marks on the camshaft timing gear have to be parallel to cylinder head base as per following illustration.

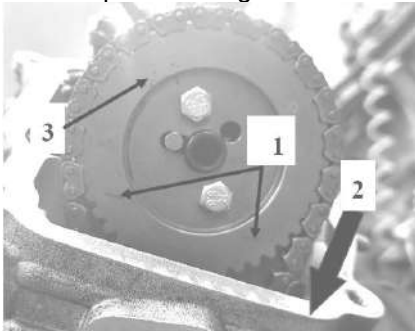

1. Printed marks on camshaft timing gear
2. Cylinder head base
3. Camshaft timing gear

Insert the feeler gauge between the valve stem end and adjusting screw on the rocker arm to check the clearance.

If the valve clearance is out of specification, adjust valves as follows.

Valve clearance	
Intake	0.05 to 0.09mm
Exhaust	0.10 to 0.15mm

Use mean valve of exhaust/intake to ensure a proper valve adjustment.

Hold the adjustment screw at the proper position and torque the locking nut.

Repeat the procedure for each valve.

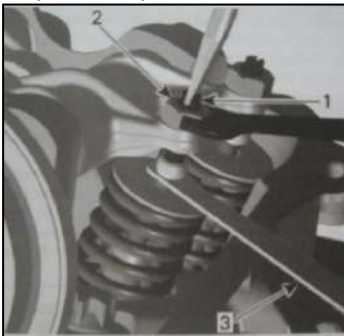

1. Adjustment screw
2. Adjustment nut
3. Feeler gauge

Valve clearance adjuster lock nut: 12Nm.

Valve clearance of cylinder 1

Using a 13 mm socket, turn crankshaft 280° counterclockwise.

Until marks on magneto flywheel "1" and magneto cover are aligned.

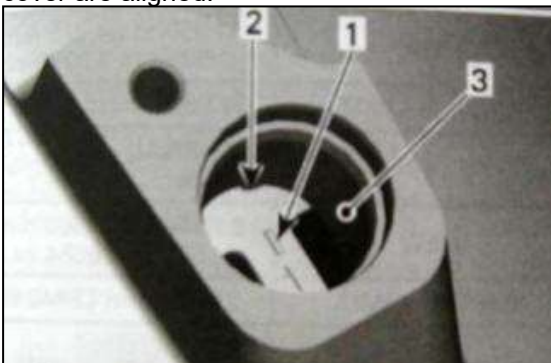

1. Mark "2" on magneto flywheel
2. Notch on magneto cover
3. Location of crankshaft position sensor

At TDC ignition, the printed marks on the camshaft timing gear have to be parallel to cylinder head base as per following illustration.

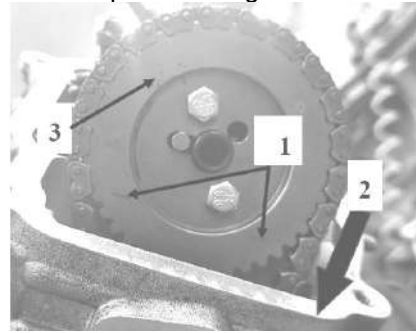

1. Printed marks on camshaft timing gear
2. Cylinder head base
3. Camshaft timing gear

Insert the feeler gauge between the valve stem end and adjusting screw on the rocker arm to check the clearance.

If the valve clearance is out of specification, adjust valves as follows.

Valve clearance	
Intake	0.05 to 0.09mm
Exhaust	0.10 to 0.15mm

Use mean valve of exhaust/intake to ensure a proper valve adjustment.

Hold the adjustment screw at the proper position and torque the locking nut.

Repeat the procedure for each valve.

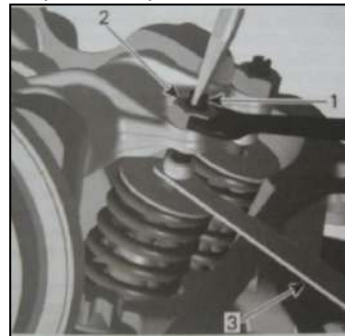

1. Adjustment screw
2. Adjustment nut
3. Feeler gauge

Valve clearance adjuster lock nut: 12Nm.

CAUTION: Securely tighten the locknut after completing adjustment.

Install the valve cover, spark plug cable and spark plug of both cylinders, the crankshaft position sensor and magneto cover.

2.4 SPARK PLUG

In case of serious wear or burn to electrode or burn to insulator by spark plug or damage to thread etc., please replace it with new spark plug

In case of carbon deposit, please use proper tools for cleaning.

Spark plug gap

Use feeler gauge to measure clearance of spark plug.

In case of exceeding designated range, then adjust the gap.

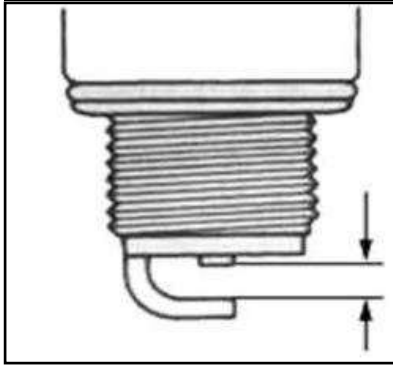

Spark plug gap: 0.7-0.9mm

Spark plug heat range

Check the spark plug heat range by observing the electrode color. If the electrode of the spark plug is appearing wet or dark color, replace the spark plug with a hotter type one. If it is white or appearing glazed, replace the spark plug with a colder type one.

Standard type: DCPR8E / NGK

Colder type: DCPR9E / NGK

Hotter type: DCPR7E / NGK

CAUTION: In order to avoiding damaging cylinder cap thread, firstly use hands to tighten spark plug and then use spark plug wrench to tighten cylinder cap with designated torque.

2.5 THROTTLE CABLE PLAY

Before starting the engine, check the throttle pedal to ensure the correct operation, and ensure that the throttle pedal can be completely restored to the idle position without the external force.

Check the free play and adjust, if needed, press the throttle to ensure that the movement of the smooth and not sticky buckle back when the check throttle pedal correctly. It must run smoothly, fully spring back to the free position.

Check throttle pedal free play:

3 - 5mm (0.118-0.197inches)

In case of out of range: → adjustment

Tilt cargo box.

Loose throttle cable (bracing cable). Turn adjuster to adjust free play of throttle pedal.



From the gate line (support), turn the regulator, regulate the solar term door handle free play.

After adjustment, tighten nut.

If free play after adjustment cannot reach designated requirement or there is viscosity for throttle valve, replace it with new throttle cable.

2.6 ENGINE OIL

Oil level verification

Strictly follow this procedure, otherwise wrong oil level may be indicated.

1.Ensure vehicle is on a level surface.

2. Start engine and let idle for a few minutes.

3. Stop engine. Wait a few minutes to allow oil to flow down to crankcase then check oil level.
4. Tilt cargo box and remove dipstick.
5. Fully screw in dipstick to check oil level.
6. Remove dipstick and read oil level. Oil level must be between minimum (2) and maximum (1) marks on dipstick.
7. There is a capacity of 300 ml between the two marks. Refill oil as necessary. Do not overfill.
8. Reinstall dipstick.

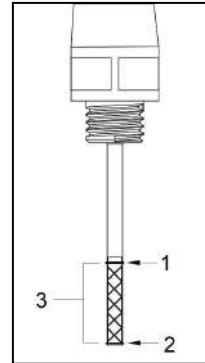

1.Full

2.Add

3.Operating range

Replace engine oil

Prior to change the oil, ensure vehicle is on a level surface. Oil and oil filter must be replaced at the same time. Oil change and oil filter replacement should be done with a warm engine.

▲ WARNING

The engine oil can be very hot. Wait until engine oil is warm.

CAUTION: Dispose oil and filter as per your local environmental regulations.

1. Ensure vehicle is on a level surface.
2. Start engine and let idle for a few minutes.
3. Stop engine. Wait a few minutes to allow oil to flow down to crankcase then check oil level.
4. Tilt cargo box.
5. Remove dipstick.
6. Raise the vehicle, support it securely. Place a drain pan under the engine drain plug area.
7. Clean the drain plug area.
8. Unscrew drain plug then remove dipstick.

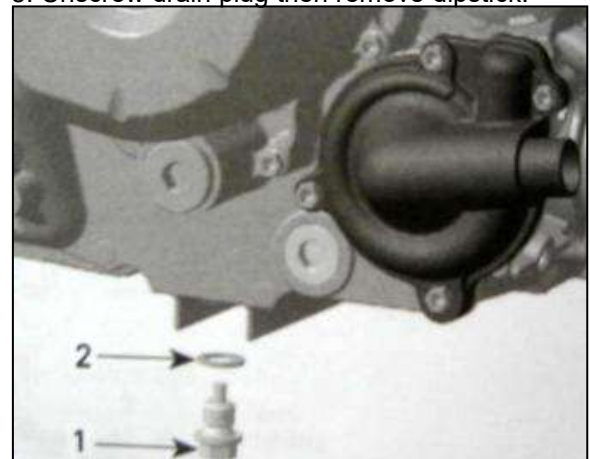

1. Oil drain Plug

2. O-ring

9. Allow oil to drain completely from crankcase.

10. Clean the magnetic drain plug from metal

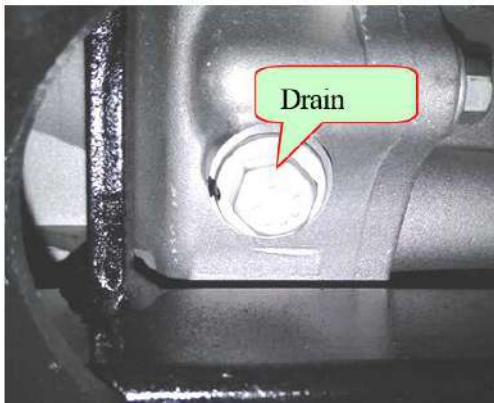

Pour the specified oil (GL-45 80W90) about 280mL by syringe through the oil level check plug hole until the oil over flows.

Tighten the oil level check plug to 20 Nm.

2.8 STEERING SYSTEM

Park vehicle at flat ground and turn handle left or right slowly to see whether it can be turned flexibly. In case of obstacles, check whether it is caused by main cable or other wiring installation. If it is not caused by above situations, please check the bottom of steering tie rod and see whether steering column bearing is damaged or not.

Park vehicle on flat ground, make sure the tire pressure for right and left tires is same and set to the proper specification, set the front wheels in the straight position, then place a load of 75kg on the seat. Measure the distance A and B of the front wheels and calculate the difference.

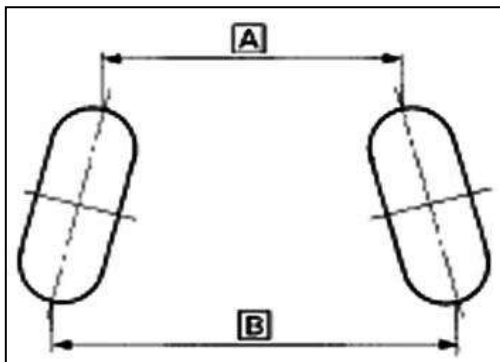

TYPICAL

A: front of front wheel

B: rear of front wheel

Toe-in.: B-A= 5mm

Out of range of toe-in: →Adjust nut of tie rod

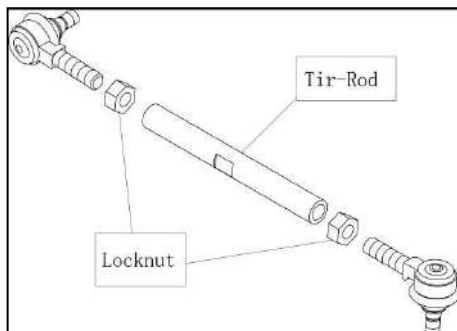

CAUTION: After adjusting toe-in, first rotate steering wheel from center position to the left and right, to ensure that is the same corner, then slowly run vehicle to see whether its direction can be controlled.

2.9 BRAKING SYSTEM

Check if any brake fluid is leaking out of the pipe joints or the brake fluid reservoir. Apply the brakes firmly for one minute. If there is any leakage, have the vehicle inspected by an authorized dealer.

Test the brakes at slow speed after starting out to make sure they are working properly. If the brakes do not provide proper braking performance, inspect the brake system. If needed, have the vehicle inspected by an authorized dealer.

Brake fluid level

Check the brake fluid level by observing the lower limit line on the brake fluid reservoir.

When brake fluid level is lower than lower limit, supplement brake fluid DOT4 in time.

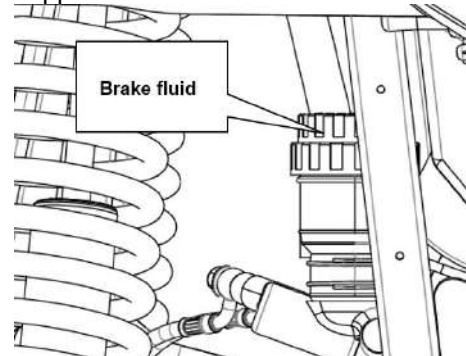

Brake pedal adjustment

The brake pedal stroke is 30 ~ 40mm. If less than equal 30mm, it will be a hidden dangers, must adjust the brake pin connecting the brake pedal.

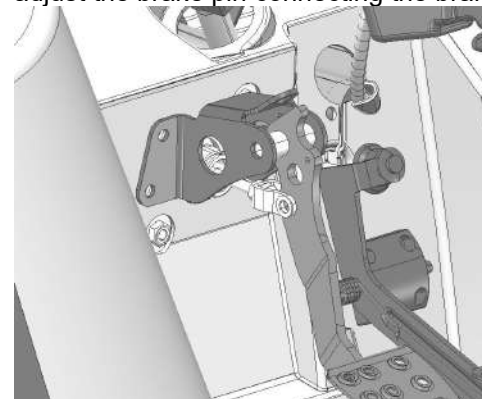

2.10 GEAR SHIFT

Check the shift lever as to change gearshift from P to R N H L and reverse smoothly. Also the meter display is correct. If not, need to adjust.

Tilt cargo box.

Unscrew the two adjust nuts on the rear side of the shift cable.

Select the shift lever to N and confirm gauge display N.

Tighten the nuts of the shift cable equably.



2.11 COOLING SYSTEM

To prevent rust formation or freezing condition, always replenish the system with the premixed coolant or with 50% antifreeze and 50% water. Do not use tap water, straight antifreeze or straight water in the system. Tap water contains minerals and impurities which build up in the system. During cold weather, straight water causes the system to freeze while straight antifreeze thickens and does not have the same efficiency. Always use ethylene glycol antifreeze containing corrosion inhibitors specifically recommended for aluminum engines. Cooling liquid may be reduced by natural evaporation. Regularly check horizontal position of cooling liquid.

Coolant level verification

Park vehicle at flat ground and check horizontal line of cooling liquid.

Remove the front panel.

Check the level of cooling water in fluid reservoir (auxiliary radiator) is between upper and lower critical levels.

▲ WARNING

To avoid potential burns, do not remove the radiator cap or loosen the cooling drain plug if the engine is hot. Never drain or refill cooling system when engine is hot.

Coolant replacement

Park vehicle at flat ground and check horizontal line of cooling liquid.

Remove the front service cover. Remove auxiliary tank cover and radiator cover.

Tilt cargo box.

Partially unscrew coolant drain plug located below water pump housing.

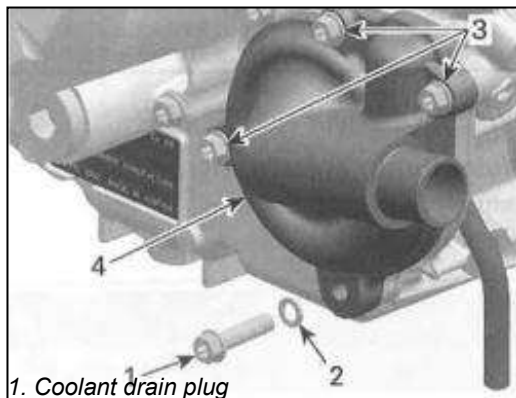

1. Coolant drain plug

2. Sealing ring

3. Screws

4. Water pump housing

When coolant is drained completely, remove cooling drain plug completely and install a new gasket ring. Screw the coolant drain bolt and torque it to 10 Nm. Unscrew bleed screws on top of thermostat housing.



Both cylinders must be bled.

Unscrew bleed bolt on top of radiator.



Fill up the radiator with coolant, when the coolant comes out by the thermostat housing hole, install the bleed screws with its gasket ring and torque to 10 Nm.

Start the engine and let idling.

Continue adding coolant to radiator, when the coolant comes out by the radiator bleed hole, install the bleed bolt with its gasket ring and torque to 10 Nm.

Press and relax the throttle pedal five times to bleed air bubbles completely.

Refill coolant tank up to upper-level mark. Install the coolant tank cap and the radiator cap.

Run engine until radiator fan opens then stop engine.

When engine has completely cooled down, recheck coolant level in radiator and coolant tank. Top up if necessary.

CAUTION: Check the general condition of hoses and clamps for tighten. Check the leak indicator pipe in front of water pump for oil and coolant.

2.12 WHEELS

Lift wheels up at horizontal position and ensure no load to each wheel.

Shake wheels to left and right to see whether their connecting parts are installed tightly and check whether they can be swung.

No adequate tightening: → tightening

Swing: → replace rocker arm



Tire pressure

Improper tire pressure will lower comfort of operation and driving and may lead to wear to side edges of tires.

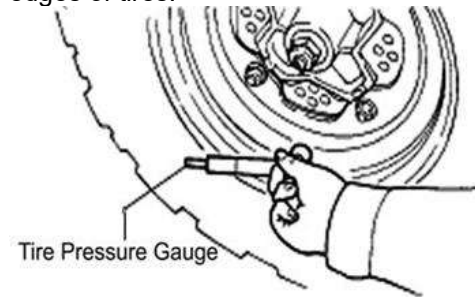

Tire thread.

When the tire groove decreases to 6 mm (0.24 in) due to wear, replace the tire.

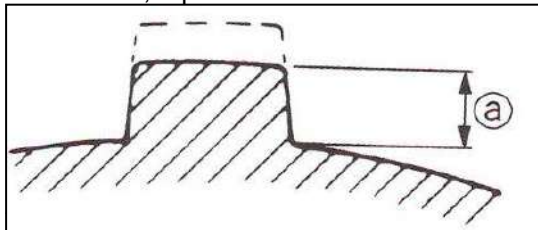

2.13 ENGINE COMPRESSION PRESSURE

The compression pressure reading of a cylinder is a good indicator of its internal condition. The decision to overhaul the cylinder is often based on results of a compression test.

Before measuring cylinder pressure, ensure installation and tightening of cylinder cap bolt with designated torque and reasonable clearance of valve.

Standard cylinder pressure: 0.9~1.2Mpa

Too low cylinder pressure may cause the following:

1. Excessive wear to cylinder;
2. Wear to piston or piston ring;
3. Blockage of piston ring in groove;
4. Close valve seat;
5. Damage to cylinder lining or faults of other parts

Measure engine compression pressure:

1. Warm up engine.
2. Ensure full charging of battery.
3. Tilt cargo box.
4. Dismantle spark plugs.
5. At spark plug hole, install cylinder pressure meter.
6. Press button of start for several seconds. Record indication of maximum cylinder pressure.

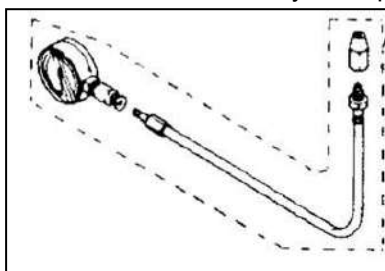

2.14 ENGINE OIL PRESSURE

Check the engine oil pressure periodically. This will give a good indication of the condition of the moving parts. The engine oil pressure test should be done with a warm engine 90°C and the recommended oil. Tilt cargo box.

Remove the oil pressure switch wire connector and switch on the left of engine.



Install oil pressure gauge and adapter hose.

Start engine on idle speed. The engine oil pressure should be within the following values.

Oil pressure	1250 RPM	6000 RPM
Minimal	70 KPa	300 KPa
Nominal	150 KPa	350 KPa
Maximal	250 KPa	450 KPa

Remove oil pressure gauge and adapter hose.

Installation oil pressure switch to 12Nm and the oil pressure switch wire connector.



2.15 SUSPENSION SYSTEM

Lubricate both suspension arms with lithium-soap based grease. There are two grease fittings on each suspension arm. Check operation and for leakage. Grease fitting location of front/rear suspension arms.

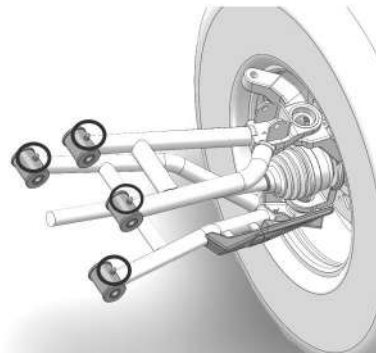

Lubricate rear knuckles with lithium-soap based grease.

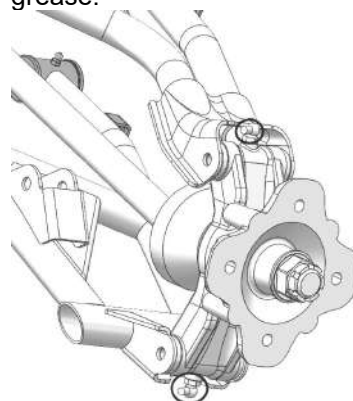

3. ENGINE

ENGINE REMOVAL.....	3-2	VALVE COVER.....	3-2
TIMING CHAIN TENSIONER.....	3-2	CAMSHAFT TIMING GEAR.....	3-3
ROCKER ARM.....	3-4	CYLINDER HEAD.....	3-5
CAMSHAFT.....	3-6	VALVE SPRING.....	3-9
VALVE.....	3-10	VALVE GUIDE.....	3-11
CYLINDER.....	3-12	PISTON.....	3-13
PISTON RINGS.....	3-15	DRIVE SHAFT.....	3-16
PTO COVER.....	3-17	DRIVE GEAR.....	3-19
TIME CHAIN.....	3-19	CRANKCASE.....	3-20
CRANKSHAFT.....	3-22	OIL PRESSURE REGULATOR.....	3-24
OIL PUMP.....	3-25	MAGNETO COVER.....	3-26
MAGNETO STATOR.....	3-27	MAGNETO ROTOR.....	3-27
SPRAG CLUTCH.....	3-28	TRANSMISSION.....	3-30
GEARBOX.....	3-34	ENGINE INSTALLATION.....	3-48

Components which are identical for both cylinders/cylinder heads are identified in the two exploded views by the same number. Components which are different or which are, for instance, present on one of the cylinders/cylinder heads but not on the other, have different numbers. The information given below always relates as a general rule.

Special reference is made in the text to work instructions which are not the same for cylinder no. 1 and cylinder no. 2.



1. Cylinder 1
2. Cylinder 2

▲ WARNING

Torque wrench tightening specifications must strictly be adhered to. Locking devices (e.g.: locking tabs, elastic stop nuts, self-locking fasteners, cotter pin, etc.) must be installed or replaced with new ones where specified. If the efficiency of a locking device is impaired, it must be repaired.

When diagnosing an engine problem, always perform a cylinder leak test. This will help pin-point a problem. Refer to the instructions included with your leak tester and to LEAK TEST section for procedures.

Always place the vehicle on level surface.

NOTE: For a better understanding, the many illustrations are taken with engine out of vehicle. To perform the following instructions, it is not necessary to remove engine from vehicle.

Always disconnect BLACK (-) cable from the battery, then RED (+) cable before working on the engine.

Even if the removal of many parts is not necessary to reach another part, it is recommended to remove these parts in order to check them.

When disassembling parts that are duplicated in the engine, (e.g.: valves), it is a strongly recommended to note their position (PTO/MAG side) and keep them as a "group". If you find a defective component, it would be much easier to find the cause of the failure among its group of parts (e.g.: you found a worn valve guide. A bent spring could be the cause and it will be easy to know which one among the springs is the cause to replace it if you grouped them at disassembly). Also, since used parts have matched together during the engine operation, they will keep their matched fit when you reassemble them together within their "group".

3.1 ENGINE REMOVAL

To avoid potential burns, let engine and exhaust system cool down before performing any servicing. Place vehicle on a work station that will have access to an engine-lifting hoist. Then start with initial preparation of vehicle.

Tilt the cargo box.

Disconnect the BLACK (-) cable from battery, then the RED (+) cable.

Drain coolant from engine cooling system. Drain engine oil only if engine overhaul is necessary. To work on gearbox the removal is necessary but do not drain engine oil.

Before remove engine, drain engine oil and coolant.

-Remove CVT air inlet and exhaust pipe.

-Remove shift arm.

-Remove throttle body, water pump inlet hose, coolant outlet hose, oil inlet hose, air inlet hose, spark plug, crankcase exhaust gas hose. Disconnect crankshaft position sensor, the speed sensor on the engine and the gear position switch, starter motor harness, disconnect the oil pressure sensor plug, engine ground harness and disconnect the engine wiring harness from the main harness.

-Remove rear wheel and disconnect rear driveshaft from engine.

-Remove seat bottom guard plate and passenger seat, then disconnect front driveshaft from engine.

-Remove engine mounting bolts on upper hang bracket and engine rear mounting board.

3.2 VALVE COVER

Cover Removal

Remove:

-Distance screws of valve cover

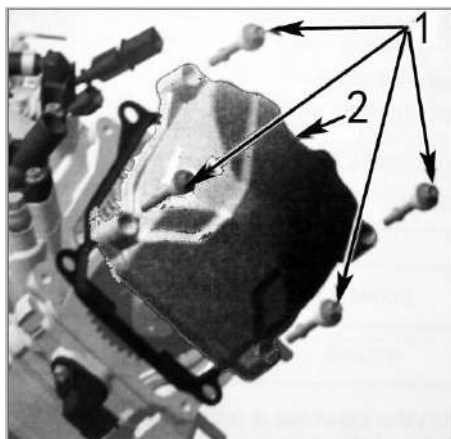

1. Distance screws

2. Valve cover

-Valve cover and gasket.



1. Valve cover

2. Gasket

Repeat the procedure for the other valve cover if required.

Cover Inspection

Check the gasket on the valve cover if it is brittle, cracked or hard. If so, replace the gasket.

Cover Installation

For installation, reverse the removal procedure.

Torque the valve cover distance screws in a crisscross sequence.

3.3 TIMING CHAIN TENSIONER

NOTE: Before removal and installation, make sure that the respective cylinder is set to TDC ignition. Refer to CAMSHAFT.

Tensioner removal

▲WARNING

Timing chain tensioner is spring loaded. Never perform this operation immediately after the engine has been turn because the exhaust system can be very hot. Wait until exhaust system is warm or cold.

Remove:

-Chain tensioner plug

-O-ring

-Spring

-Chain tensioner plunger

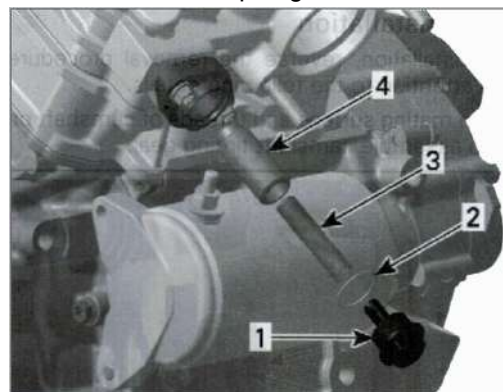

1. Chain tensioner plug

2. O-ring

3. Spring

4. Chain tensioner plunger

Screws retaining chain tensioner housing

-Chain tensioner housing with O-ring

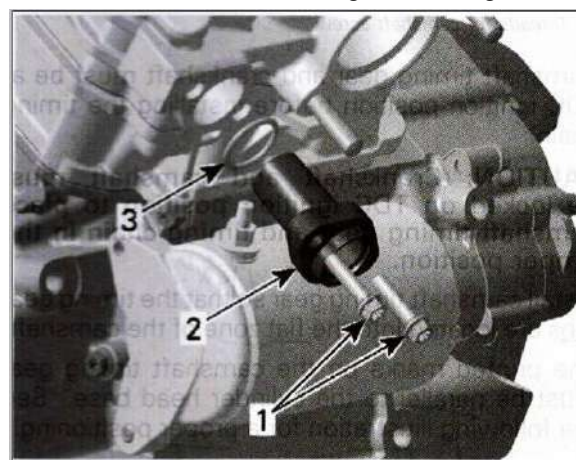

1. Chain tensioner screws

2. Chain tensioner housing

3. O-ring

Tensioner Inspection

Check the housing for cracks or other damages.

Replace if necessary.
 Check chain tensioner plunger for free movement and/or scoring.
 Check if O-rings are brittle, cracked or hard.
 Replace if necessary.
 Check spring condition. Replace if broken or worn.

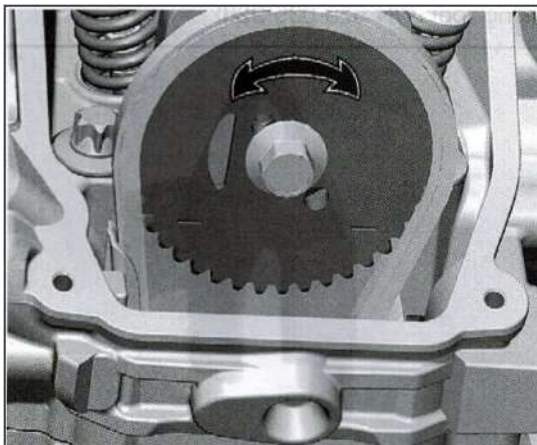

Tensioner Installation

For installation, reverse the removal procedure. However, pay attention to the following.

NOTE: Before installing the chain tensioner make sure, that the camshaft timing gear can be moved back and forth.

Apply engine oil on the plunger before installing.

NOTE: Slightly screw in the plunger until the timing chain allows no more back and forth movement of the camshaft timing gear. Then screw in the plunger an additional 1/8 turn to reach the required torque of 0.1 Nm.

CAUTION: Improper adjustment of the timing chain will lead to severe engine damage.

Fit the spring on one side into the slot of the plug screw and on the other side into the plunger. Turn spring only clockwise in order to fit the spring end into the notch of the plunger and to avoid loosening the plunger during spring installation. Do not preload the spring.

NOTE: Do not forget to place the O-ring on chain tensioner plug.

Then compress the spring and screw in plug screw. Finally, tighten the plug screw to 4.5 Nm.

3.4 CAMSHAFT TIMING GEAR

Gear Removal

Turn crankshaft to TDC ignition of the respective cylinder.

Unscrew timing chain tensioner.

Remove camshaft timing gear screw.

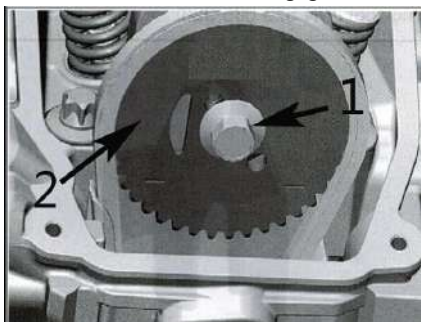

1. Camshaft timing gear screw
2. Camshaft timing gear

Remove the camshaft timing gear.

NOTE: Secure timing chain with a retaining wire.

Gear Inspection

Check camshaft timing gear for wear or deterioration.

If gear is worn or damaged, replace it as a set (camshaft timing gear and timing chain).

Gear Installation

For installation, reverse the removal procedure. Pay attention to the following details.

Clean mating surface and threads of camshaft, prior to assemble camshaft timing gear.

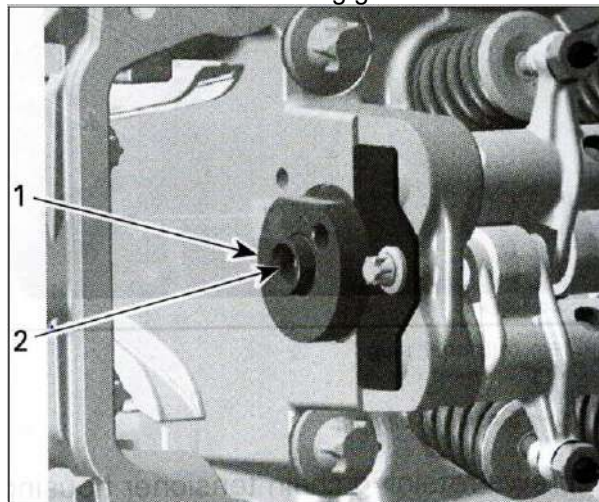

1. Mating surface on camshaft
2. Threads for camshaft screw

Camshaft timing gear and crankshaft must be at TDC ignition position before installing the timing chain.

CAUTION: Crankshaft and camshaft must be locked on TDC ignition position to place camshaft timing gear and timing chain in the proper position. Install camshaft timing gear so that the timing gear tabs are located into the flat zone of the camshaft.

The printed marks on the camshaft timing gear must be parallel to the cylinder head base. See the following illustration for a proper positioning.

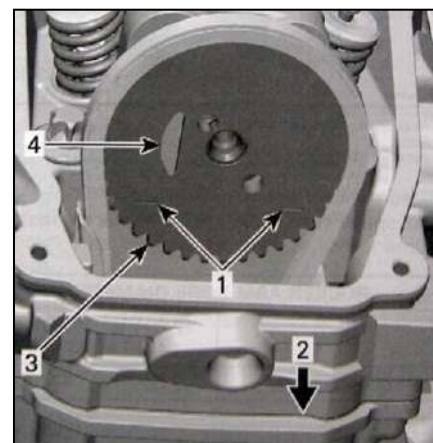

1. Printed marks on camshaft timing gear
2. Cylinder head base
3. Camshaft timing gear
4. Timing gear tab

Install trigger wheel on camshaft timing gear of cylinder 1.

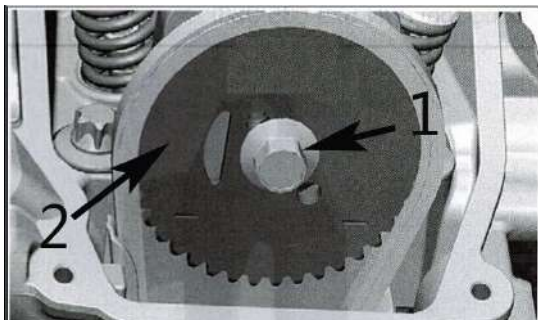

1. Camshaft timing gear screw
2. Camshaft timing gear

When the camshaft timing gear and the timing chain are installed, remove the crankshaft locking bolt as well as the camshaft locking tool.

NOTE: Before installing the camshaft screw adjust the chain tension and check again if marks on the timing gear are parallel to cylinder head base.

Reinstall all other removed parts.

3.5 ROCKER ARM

Rocker Arm Removal

Remove:

- Valve cover
- Chain tensioner
- Camshaft timing gear
- Allen screw and camshaft retaining plate

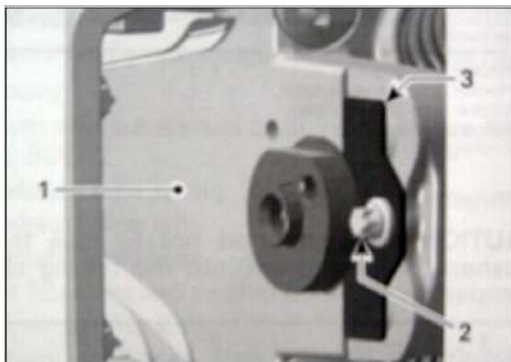

1. Cylinder head
2. Allen screw
3. Camshaft retaining plate

- Rocker arm shafts
- Rocker arm assembly (exhaust side and intake side) with adjustment screws and nuts.

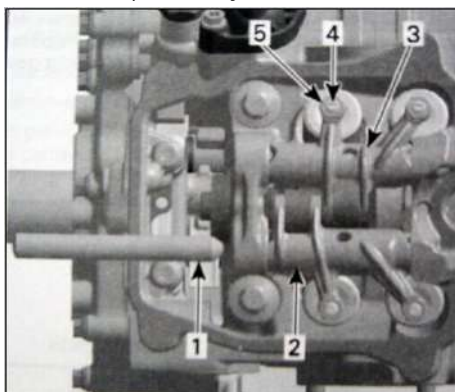

1. Rocker arm shaft
2. Rocker arm (exhaust side)
3. Rocker arm (intake side)
4. Adjustment screw
5. Locking nut

- Thrust washer

CAUTION: Pay attention not to lose thrust washers

or drop them into the timing chain compartment.

Rocker Arm Inspection

Inspect each rocker arm for cracks and scored friction surfaces. If so, replace rocker arm assembly. Check the rocker arm rollers for free movement, wear and excessive radial play. Replace rocker arm assembly if necessary.

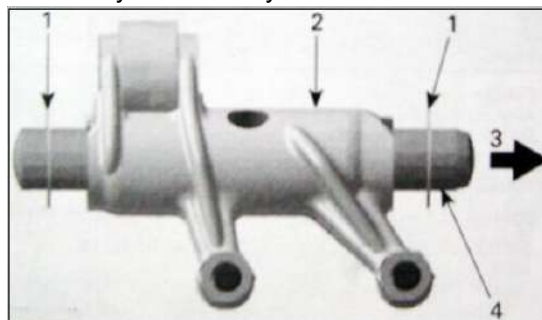

1. Rocker arm (exhaust side)
2. Roller
3. Bore for rocker arm shaft

Measure rocker arm bore diameter. If diameter is out of specification, change the rocker arm assembly.

Rocker arm bore diameter	
new	12.000 to 12.018 mm
Service limit	12.030 mm

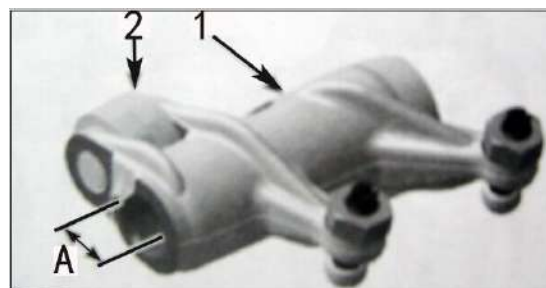

Check adjustment screws for free movement, cracks and/or excessive play.

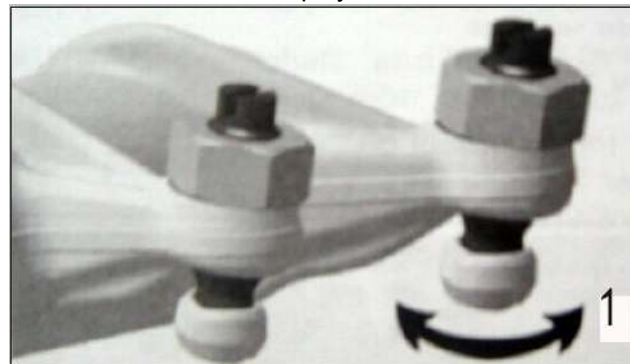

1. Free movement of adjustment screw top

Rocker arm shaft

Check for scored friction surfaces, if so, replace parts.

Measure rocker arm shaft diameter.



A: Measure rocker arm shaft diameter here

Rocker arm shaft diameter	
New	11.983 to 11.994 mm
Service limit	11.970 mm

Any area worn excessively will require parts replacement.

Rocker Arm Installation

NOTE: use the same procedure for exhaust and intake rocker arm.

Apply engine oil on rocker arm shaft.

Install the rocker arm shafts with the chamfered edge first and use following procedure:

-Insert a rocker arm pin through rocker arm pin bore.

-Install a thrust washer then the proper rocker arm.

-Push in rocker arm shaft until its chamfer reaches the end of rocker arm bore.

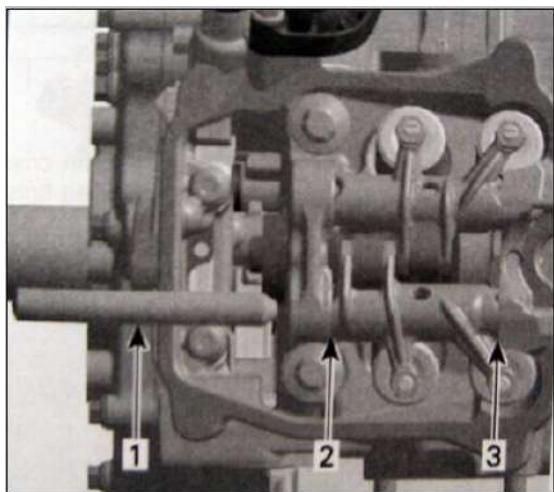

1. Rocker arm shaft
2. Thrust washer (timing chain side)
3. Thrust washer (spark plug side)

-Place the other thrust washer and push rocker arm shaft to end position.

-Install the camshaft retaining plate.

3.6 CYLINDER HEAD

Cylinder Head Removal

The removal procedure is the same for both cylinder heads.

Drain coolant.

CAUTION: Before removing cylinder head, blow out remaining coolant by air pressure. During cylinder head removal, the remaining coolant in cylinder head could overflow into the engine and a little quantity of coolant could drop into the engine. In this case, the engine oil will be contaminated.

Disconnect:

- Spark plug wire
- Temperature sensor connector, located at rear cylinder head

Remove:

- Exhaust pipe spring
- Exhaust pipe nuts
- Radiator inlet hose
- Air filter box and throttle body
- Air intake manifold
- Chain tensioner
- Valve cover and gasket
- Camshaft timing gear

- Cylinder head screws M6
- Cylinder head screws M10 retaining cylinder head and cylinder to cylinder base.

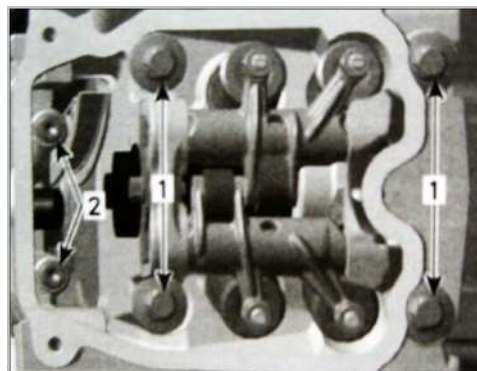

1. Cylinder head screws M10
2. Cylinder head screws M6

Pull up cylinder head.

Remove:

- Chain guide
- Cylinder head gasket and scrap it.

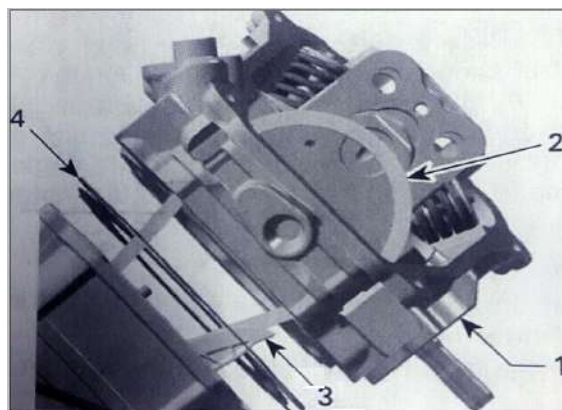

1. Cylinder head
2. Timing chain
3. Chain guide
4. Cylinder head gasket

Cylinder Head Inspection

Inspect timing chain guide for wear, cracks or other damages. Replace if necessary.

Check for cracks between valve seats, if so, replace cylinder head.

Check mating surface between cylinder and cylinder head for contamination. If so, clean both surfaces.

Clean oil support through the cylinder head from contamination.

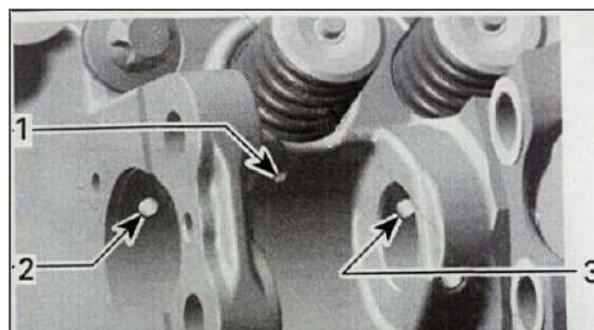

1. Oil port to lubricate camshaft lobes intake/exhaust
2. Oil supply to camshaft bearing journal timing chain side
3. Oil supply to camshaft bearing journal spark plug side

Cylinder Head Installation

NOTE: The cylinder heads are not identical in design. Do not invert the cylinder heads at assembly.

For installation, reverse the removal procedure. Pay attention to the following details.

Ensure dowel pins are in place.

CAUTION: Chain guide has to be fixed between cylinder and cylinder head.

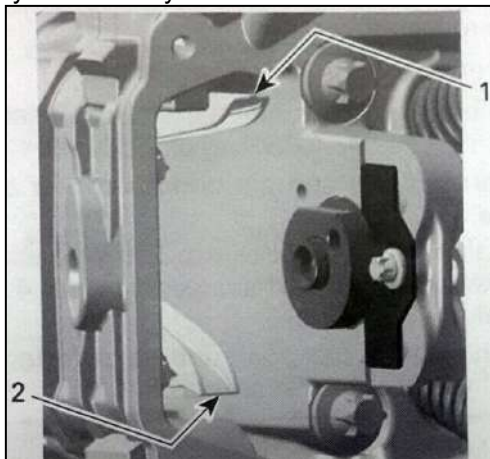

1. Chain guide (fixed between cylinder and cylinder head)

2. Chain tensioner guide (mounted in crankcase)

Install a new cylinder head gasket.

First, torque cylinder head screws M10 in crisscross sequence to 20 Nm then finish by tightening to 60 Nm.

Install cylinder head screws M6.

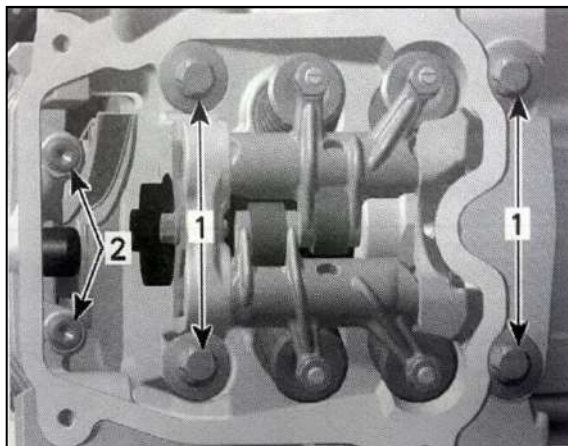

1. Cylinder head screws M10

2. Cylinder head screws M6

Check chain guide for movement.

Remove crankshaft locking bolt and reinstall plug screw with sealing ring.

3.7 CAMSHAFT

NOTE: The engine is equipped with two different camshafts.



1. Camshaft of cylinder 1

2. Camshaft of cylinder 2

Camshaft timing cylinder 2

Turn crankshaft until piston is at TDC ignition as follows.

Remove:

-Spark plug cable and spark plug of both cylinders

-Valve cover of both cylinders

-Plug screw and O-ring of magneto cover

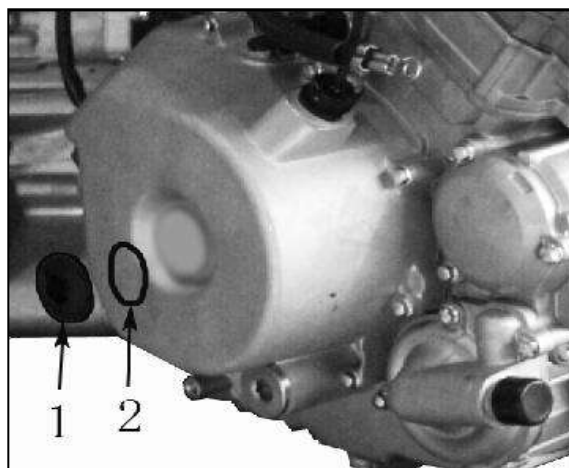

1. Plug screw

2. O-ring

-Crankshaft position sensor

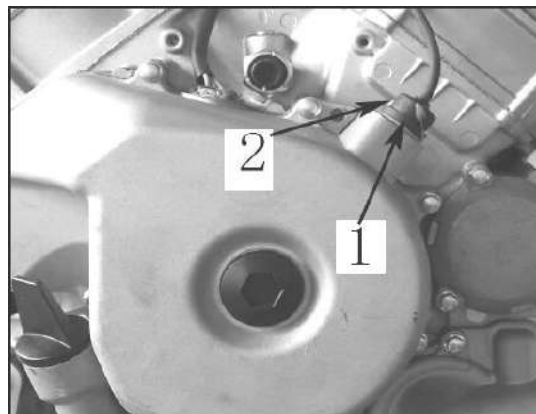

1. Crankshaft position sensor

2. Screw

Use a 14 mm Allen key to turn crankshaft until piston 2, rear is at TDC ignition.

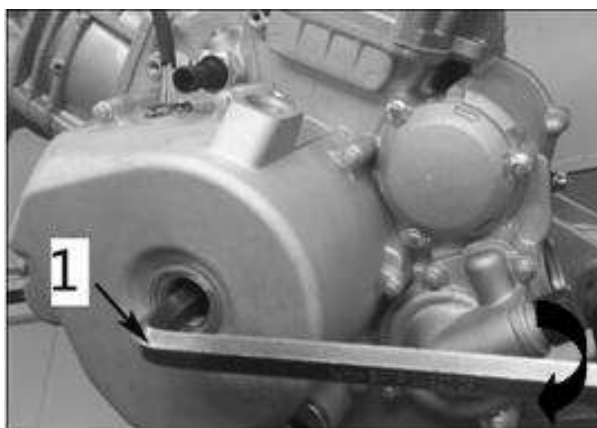

1. Allen key 14 mm

When rear piston is at TDC ignition, marks on magneto flywheel "2" and on the magneto cover are aligned.

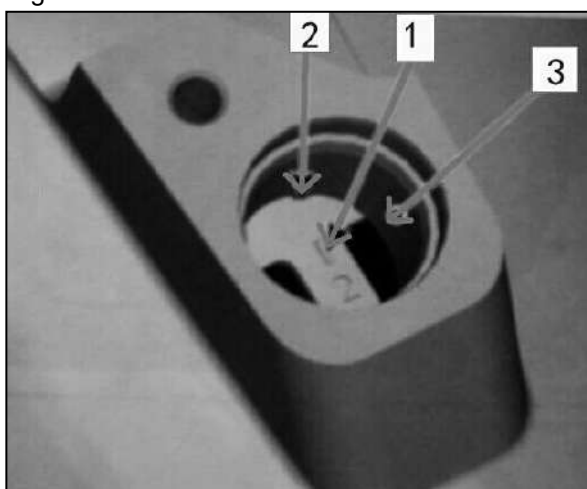

1. Mark "2" on magneto flywheel
2. Notch on magneto cover
3. Crankshaft position sensor location

At TDC ignition, the printed marks on the camshaft timing gear have to be parallel to cylinder head base.

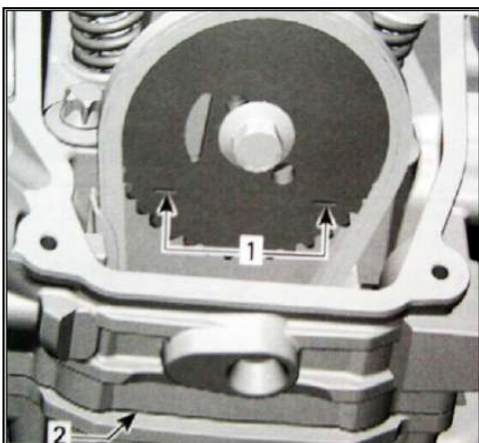

1. Printed marks on camshaft timing gear
2. Cylinder head base

To lock crankshaft at TDC ignition, proceed as follows.

Remove from crankcase plug screw with sealing ring.

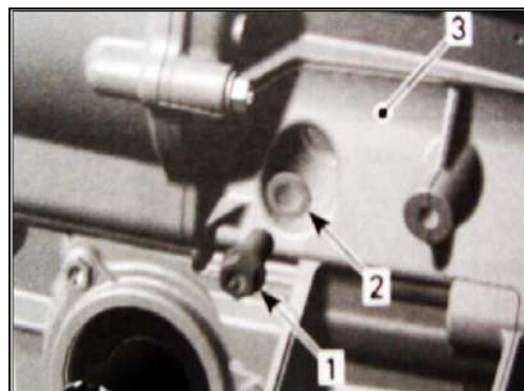

1 Plug screw
2 Sealing ring
3 Crankcase PTO side, front side

Lock crankshaft with crankshaft locking bolt.

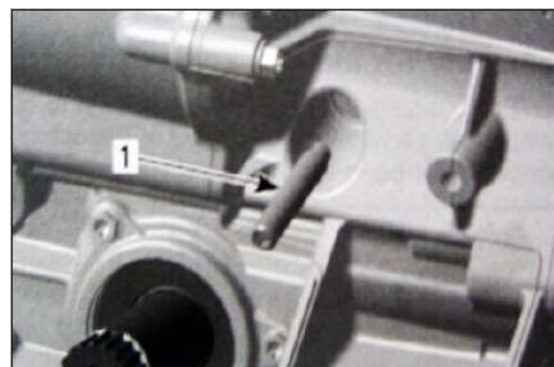

1. Crankshaft locking bolt

NOTE: Make sure the locking bolt engages in the groove of the crankshaft.

Camshaft Timing Cylinder 1

Using a 14 mm Allen key, turn crankshaft 280° counterclockwise, until marks on magneto flywheel "1" and magneto cover are aligned.



1. Allen key 14mm
2. Turn crankshaft 280° counterclockwise

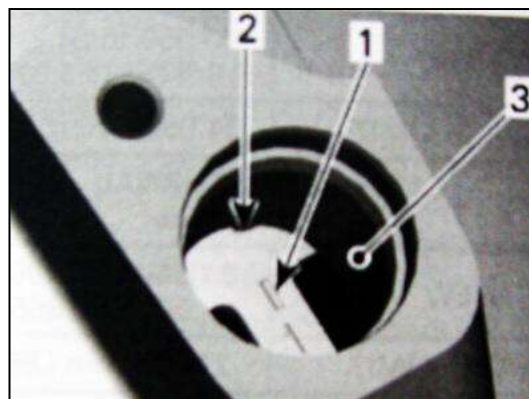

1. Mark "1" on magneto flywheel
2. Notch on magneto cover
3. Location of crankshaft position sensor

NOTE: At TDC ignition, the printed marks on the camshaft timing gear have to be parallel to cylinder head base as per following illustration.

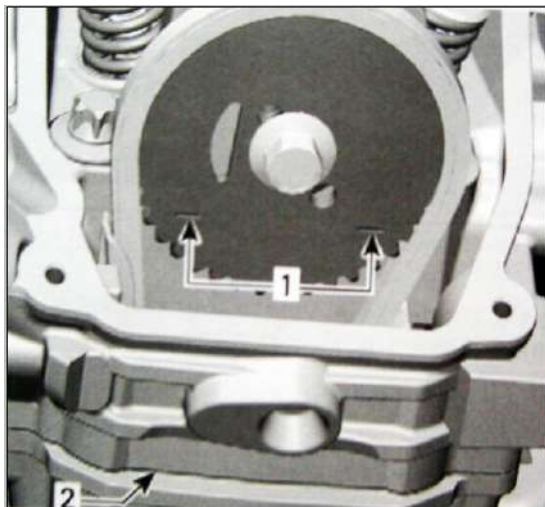

1. Printed marks on camshaft timing gear
2. Cylinder head base

CAUTION: Crankshaft can not be locked at cylinder 1 TDC ignition.

Camshaft Removal

The removal procedure is the same for both camshafts.

Each camshaft is different in design. Thus, it is important not to mix up any parts of the camshaft assembly with that of the other cylinder. Keep parts as a group.

Remove:

- Valve cover (see VALVE COVER above)
- Chain tensioner (see CHAIN TENSIONER above)
- Camshaft timing gear (see CAMSHAFT TIMING GEAR above)
- Camshaft retaining plate

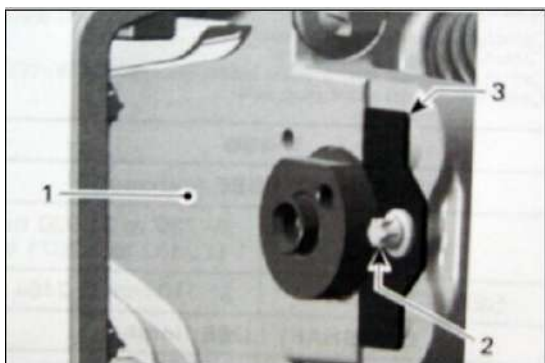

1. Cylinder head
 2. Allen screw
 3. Camshaft retaining plate
- Rocker arms (see ROCKER ARM above)
 - Camshaft.

NOTE: For removal rotate camshaft so that intake/exhaust lobe shows to upper side of cylinder head.

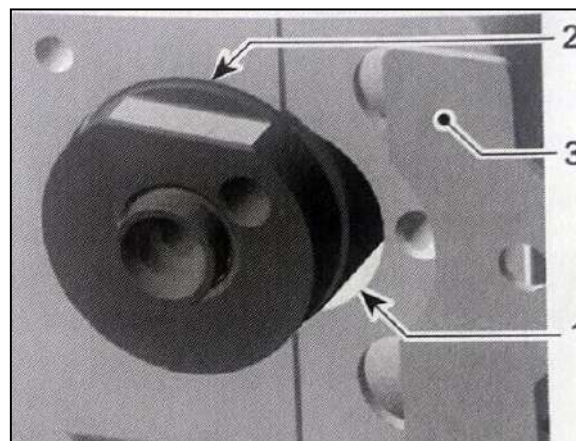

1. Area for camshaft lobes
2. Camshaft
3. Camshaft retaining

Camshaft Inspection

Check each lobe and bearing journal of camshaft for scoring, scuffing, cracks or other signs of wear. Measure camshaft bearing journal diameter and lobe height using a micrometer.

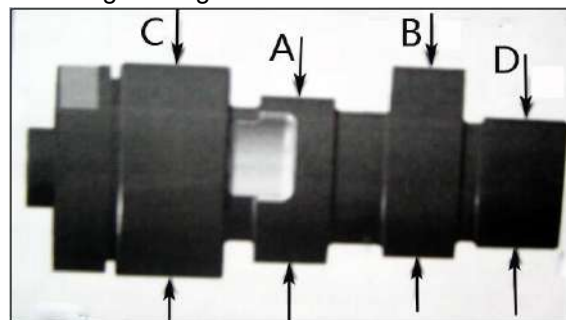

- A. Camshaft lobe (exhaust valves)
- B. Camshaft lobe (intake valves)
- C. Camshaft journal timing chain side
- D. Camshaft journal spark plug side

Camshaft lobe (exhaust)	
New	31.95 to 32.05mm
Service limit	31.92mm
Camshaft lobe (intake)	
New	32.15 to 32.25 mm
Service limit	32.09 mm

Camshaft journal (timing chain side)	
New	34.959 to 34.975 mm
Service limit	34.94mm
Camshaft journal (spark plug side)	
New	35 to 35.025 mm
Service limit	35.04 mm

Measure clearance between both ends of camshaft and cylinder head. Replace parts that are not within specifications.

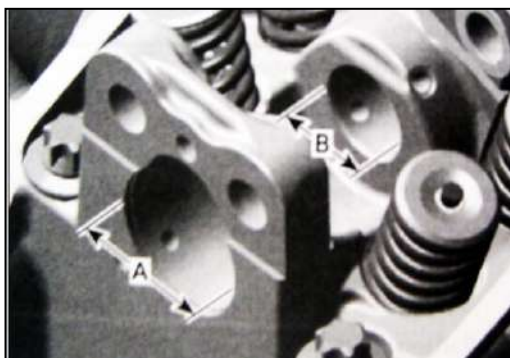

- A. Cylinder head camshaft bearing timing chain side
- B. Cylinder head camshaft bearing spark plug side

Cylinder head camshaft bearing (timing chain side)	
New	35.000 to 35.025 mm
Service limit	35.040 mm
Cylinder head camshaft bearing (spark plug side)	
New	22.000 to 22.021 mm
Service limit	22.040 mm

Camshaft Installation

For installation, reverse the removal procedure. Pay attention to the following details.

CAUTION: The camshafts are not identical in design. Do not invert the camshafts during assembly. Any mix-up of the components will lead to engine damage.

Place the camshaft retaining plate in the slot of the camshaft.

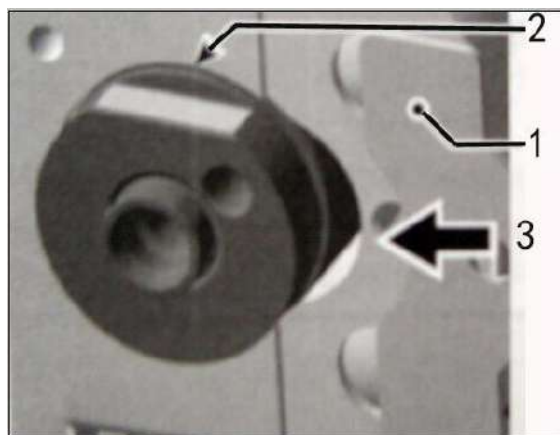

- 1. Camshaft retaining plate position
- 2. Slot retaining camshaft
- 3. Direction of movement

For other parts, refer to proper installation procedure.

3.8 VALVE SPRING

Valve Spring Removal

Remove:

- Rocker arms (see ROCKER ARM above)
- Cylinder head (see CYLINDER HEAD above).

Compress valve spring; use valve spring compressor clamp and valve spring compressor cup.

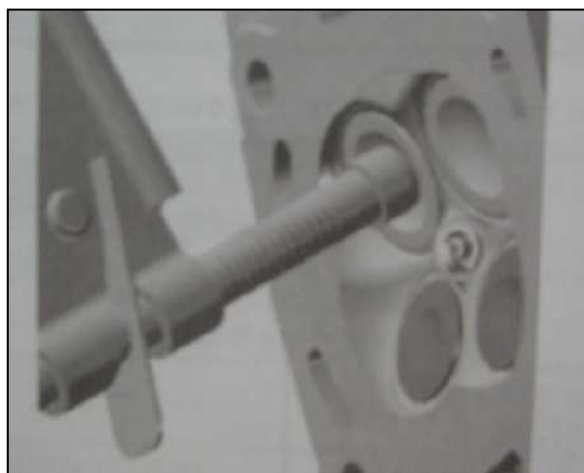

▲WARNING

Always wear safety glasses when disassembling valve springs. Be careful when unlocking valves. Components could fly away because of the strong spring preload.

Remove valve cotters.

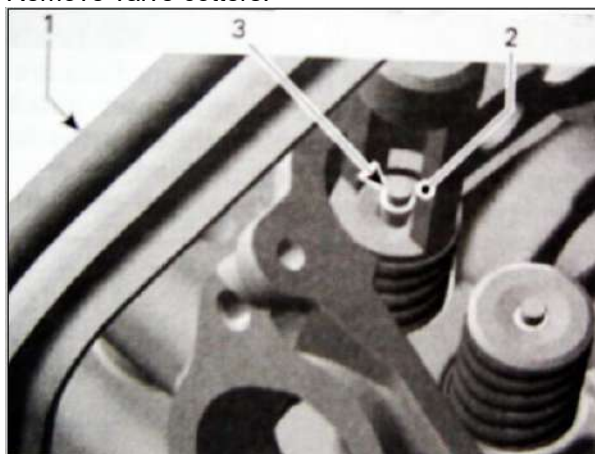

- 1. Valve spring compressor clamp
- 2. Valve spring compressor cup
- 3. Valve cotter

Withdraw valve spring compressor, valve spring retainer and valve spring.

Valve Spring Inspection

Check valve spring for visible damages. If so, replace valve spring.

Check valve spring for free length and straightness. Replace valves springs if not within specifications.

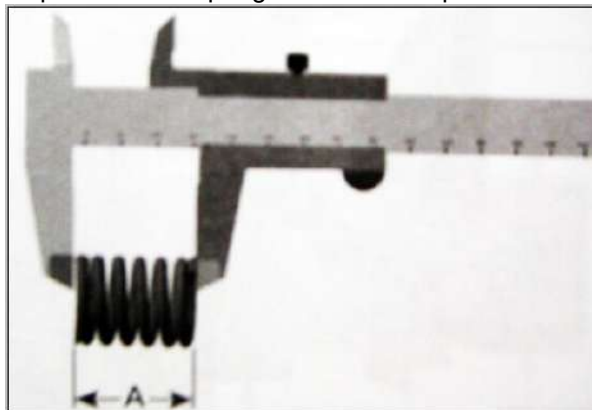

- A. Valve spring length

Valve spring free length	
Normal New	40.5 mm
Service limit	39.00 mm

Valve Spring Installation

For installation, reverse the removal procedure. Pay attention to the following details.

Colored area of the valve spring must be placed on top.

To ease installation of cotters, apply oil or grease on them so that they remain in place while releasing the spring.

NOTE: Valve cotter must be properly engaged in valve stem grooves.



1. Position of the spring
2. Valve cotter

After spring is installed, ensure it is properly locked by tapping on valve stem end with a soft hammer so that valve opens and closes a few times.

CAUTION: An improperly locked valve spring will cause engine damage.

3.9 VALVE

VALVE Removal

Remove valve spring, see VALVE SPRING above. Push valve stem, then pull valves (intake and exhaust) out of valve guide.

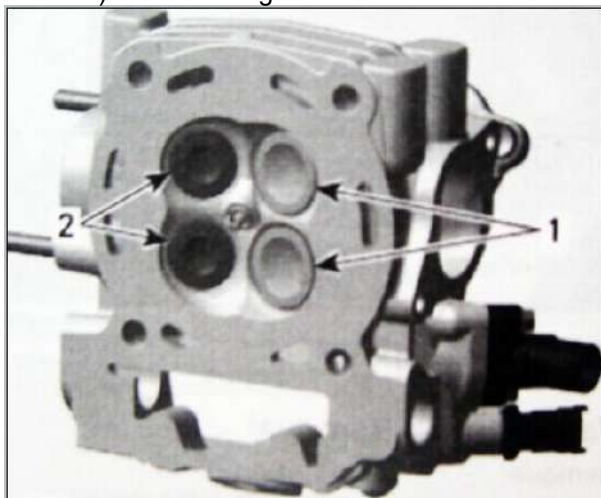

1. Intake valves 31mm
2. Exhaust valve 27mm

Remove valve stem seal with Snap-On pliers and discard it

Valve Inspection

Valve Stem seal

Always install new seals whenever valves are removed.

Valve

Inspect valve surface, check for abnormal stem wear and bending. If out of specification, replace by a new one.

Valve out of round (intake and exhaust valves)	
New	0.006 mm
Service limit	0.06 mm

Valve Stem and Valve Guide Clearance

Measure valve stem and valve guide in three places using a micrometer and a small bore gauge.

NOTE: Clean valve guide to remove carbon deposits before measuring.

Change valve if valve stem is out of specification or has other damages such as wear or friction surface.

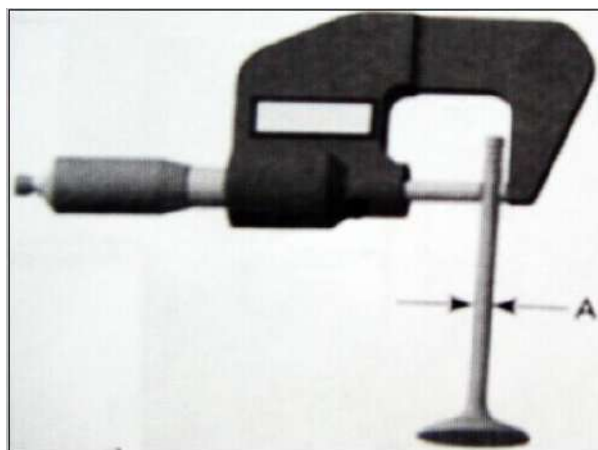

A. Valve stem diameter

Valve stem diameter	
Exhaust valve	
New	4.945 to 4.965 mm
Service limit	4.930 mm
Intake valve	
New	4.960 to 4.975 mm
Service limit	4.930 mm

Replace valve guide out of cylinder head if valve guide or out of specification or has other damages such as wear or friction surface (see VALVE GUIDE PROCEDURE below)

Valve guide diameter (intake and exhaust valves)	
New	5.000 to 5.015 mm
Service limit	5.050 mm

Valve Face and Seat

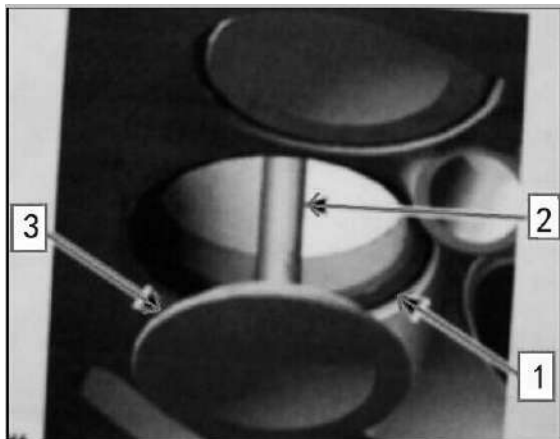

1. Valve seat
2. Exhaust valve contaminated
3. Valve face (contact surface to valve seat)

Check valve face and seat for burning or pitting.

and replace valve or cylinder head if there are signs of damage.

Ensure to seat valve properly. Apply some lapping compound to valve face and work valve on its seat with a lapping tool (see VALVE GUIDE PROCEDURE below).

Measure valve face contact width.

NOTE: The location of contact area should be in center of valve seat.

Measure valve seat width using a caliper.

Valve seat contact width	
Exhaust valve	
New	1.25 to 1.55 mm
Service limit	2.00 mm
Intake valve	
New	1.05 to 1.35 mm
Service limit	1.80 mm

If valve seat contact width is too wide or has dark spots, replace the cylinder head.

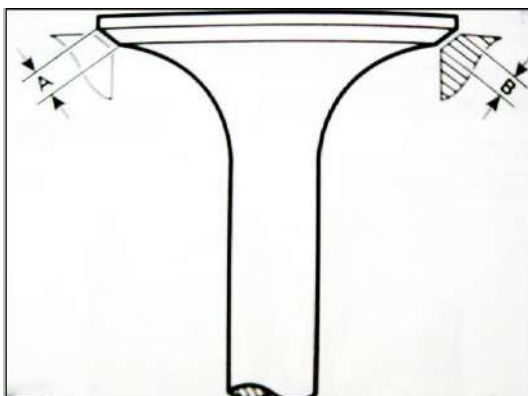

- A. Valve face contact width
- B. Valve seat contact width

Valve installation

For installation, reverse the removal procedure. Pay attention to the following details.

Install a NEW valve stem seal. Make sure thrust washer is installed before installing seal.

Apply engine oil on valve stem and install it.

CAUTION: Be careful when valve stem is passed through sealing lips of valve stem seal.

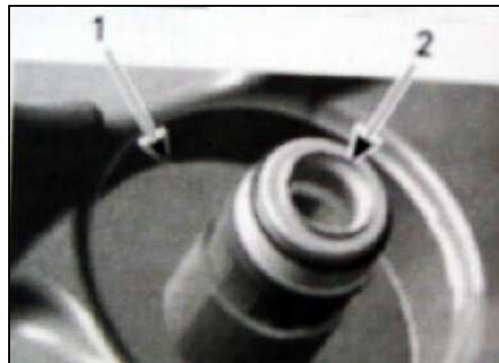

1. Thrust washer
2. Sealing lips of valve stem seal.

To ease installation of cotters, apply oil or grease on them so that they remain in place while releasing the spring.

After spring is installed, ensure it is properly locked by tapping on valve stem end with a soft hammer so that valve opens and closes a few times.

CAUTION: An improperly locked valve spring will cause engine damage.

3.10 VALVE GUIDE

Valve Guide Removal

Remove:

- Cylinder head (see CYLINDER HEAD above)
- Valve spring (see VALVE SPRING above)
- Valves (see VALVE above)

NOTE: Clean valve guide area from contamination before removal.

Using valve guide remover, remove valve guide with a hammer.



1. Valve guide remover
2. Valve guide

Valve Guide Inspection

Always replace valve stem seals whenever valve guides are removed.

Clean the valve guide bore before reinstalling the valve guide into cylinder head.

Valve Guide Installation

For installation, reverse the removal procedure. Pay attention to the following details.

Use valve guide installer to install valve guide.



NOTE: Apply LOCTITE 767 on valve guide prior to

install it into the cylinder head.
Valve guide to be adjusted in diameter by using a reamer.

Valve guide diameter (intake and exhaust valves)	
new	5.000 to 5.015 mm
Service limit	5.050mm

NOTE: Ensure to turn reamer in the right direction. Using cutting oil and make brakes to clean reamer/valve guide from metal shavings. Apply some lapping compound to valve face and work valve on its seat with a lapping tool.



1. Valve seat
2. Valve face (contact surface to valve seat)
3. Turn valve while pushing against cylinder head
- A. Valve seat angle 45°

NOTE: Ensure to seat valves properly. Apply marking paste to ease checking contact pater. Repeat procedure until valve seat/valve face fits together.

3.11 CYLINDER Cylinder removal

Remove:

- Chain tensioner (see CHAIN TENSIONER)
- Camshaft timing gear (see CAMSHAFT TIMING GEAR)
- Cylinder head (see CYLINDER HEAD)

Pull cylinder.

Discard cylinder base gaskets.



1. Cylinder
2. Piston assembly
3. Cylinder base gasket
4. Camshaft timing chain

Cylinder Inspection

Check cylinder for cracks, scoring and wear, ridge on the top and bottom of the cylinder. If so, replace cylinder.

Cylinder taper

Measure cylinder bore and if it is out of

specifications, replace cylinder and piston rings. Measure cylinder bore at 3 recommended positions. See the following illustration.

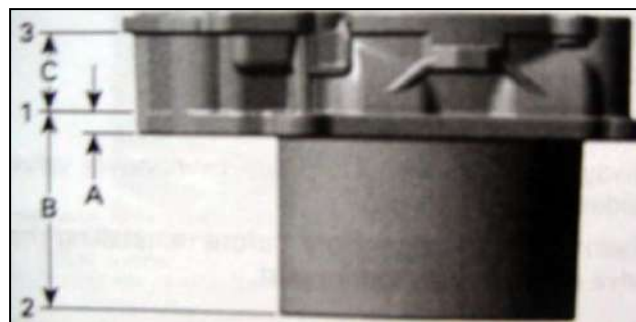

1. First measuring of diameter
2. Second measuring of diameter
3. Third measuring of diameter
- A. 7mm from cylinder bottom
- B. 68mm
- C. 32mm

Distance between measurements should not exceed the service limit mentioned above

Cylinder out of Round

Measure cylinder diameter in piston axis direction from top of cylinder. Take another measurement 90° from first one and compare.

NOTE: Take the same measuring points like described in CYLINDER TAPER above.

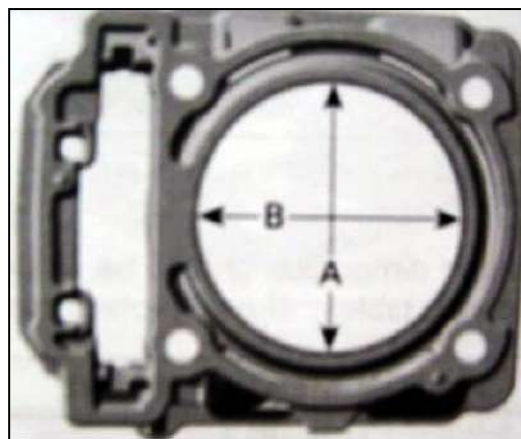

- A. Perpendicular to crankshaft axis
- B. Parallel to crankshaft axis

Cylinder out of round	
New (maximum)	0.003 mm
Service limit	0.020 mm

Cylinder Installation

For installation, reverse the removal procedure. Pay attention to the following details.

CAUTION: Always replace cylinder base gasket before installing the cylinder.

First mount cylinder 2 then remove crankshaft locking bolt. Crank the engine further and position piston 1 at TDC. Mount cylinder 1. The cylinder can not be pushed fully over the piston unless the piston is located at TDC.

Apply engine oil in the bottom area of cylinder bore and also on the band of the piston ring compressor tool.

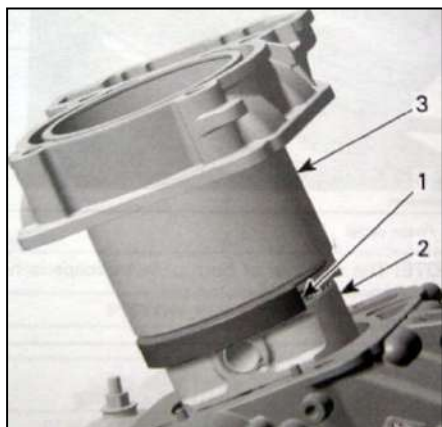

- 1. Piston ring compressor
- 2. Piston
- 3. Cylinder

NOTE: Put timing chain through the chain pit then put the cylinder in place.

CAUTION: Chain guide has to be fixed between cylinder and cylinder head.

NOTE: After both cylinders are installed, turn crankshaft until piston of cylinder 2 is at TDC ignition and lock crankshaft. Install cylinder head and the other parts in accordance with the proper installation procedures.

3.12 PISTON

Piston removal

Remove:

- Cylinder head (see CYLINDER HEAD above)
- Cylinder (see CYLINDER above).



Place a rag under piston and in the area of timing chain compartment.

Remove one piston circlip and discard it.

NOTE: The removal of both piston circlips is not necessary to remove piston pin.

Push piston pin out of piston.

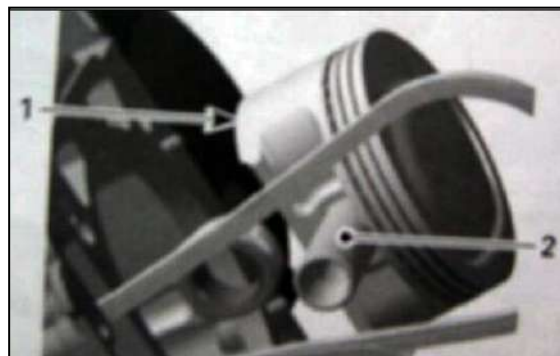

- 1. Piston
- 2. Piston Pin

Detach piston from connecting rod.

Piston Inspection

Inspect piston for scoring, cracking or other damages. Replace piston and piston rings if necessary.

Using a micrometer, measure piston at 8 mm perpendicularly (90°) to piston pin.

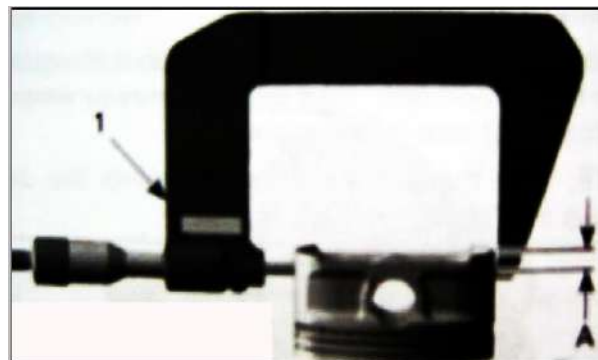

- 1. Measuring perpendicularly to piston pin
- A. 8 mm

The measured dimension should be as described in the following tables. If not, replace piston.

Piston measurement	
Size "A"	
New	90.955 to 90.962mm
Service limit	90.930mm
Size "B"	
New	90.962 to 90.970 mm
Service limit	90.940mm

Piston/Cylinder Clearance

Adjust and lock a micrometer to the piston dimension.



- 1. Micrometer set to the piston dimension

With the micrometer set to the dimension, adjust a cylinder bore gauge to the micrometer dimension and set the indicator to 0 (zero).



1. Use the micrometer to set the cylinder bore gauge
2. Dial bore gauge

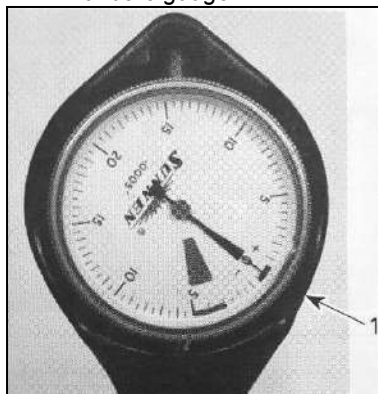

1. Indicator set to 0

Position the dial bore gauge 20 mm above cylinder base, measuring perpendicularly (90°) to piston pin axis.

Read the measurement on the cylinder bore gauge. The result is the exact piston/cylinder wall clearance.

Cylinder taper in diameter	
New (maximum)	0.033-0.048 mm
Service limit	0.090 mm

NOTE: Make sure used piston is not worn.

If clearance exceeds specified tolerance; replace piston by a new one and measure piston/cylinder clearance again. Make sure the cylinder bore gauge indicator is set exactly at the same position as the micrometer, otherwise the reading will be false.

Connecting Rod/Piston Pin clearance

Using synthetic abrasive woven clean piston pin from deposits.

Inspect piston pin for scoring, cracking or other damages.

Measure piston pin. See the following illustration for the proper measurement positions.

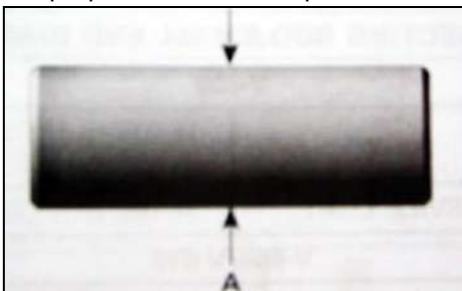

- A. Piston pin diameter

Piston pin diameter	
New	19.996 to 20.000 mm
Service limit	19.980 mm

Replace piston pin if diameter is out of specifications.

Measure inside diameter of connecting rod small end bushing.

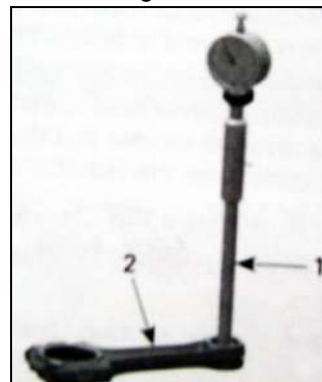

1. Bore gauge
2. Connecting rod

Connecting rod small end diameter	
New	20.010 to 20.020 mm
Service limit	20.060 mm

Replace connecting rod if diameter of connecting rod small end is out of specifications.

Piston Installation

For installation, reverse the removal procedure. Pay attention to the following details.

Apply engine oil on the piston pin.

Insert piston pin into piston and connecting rod.

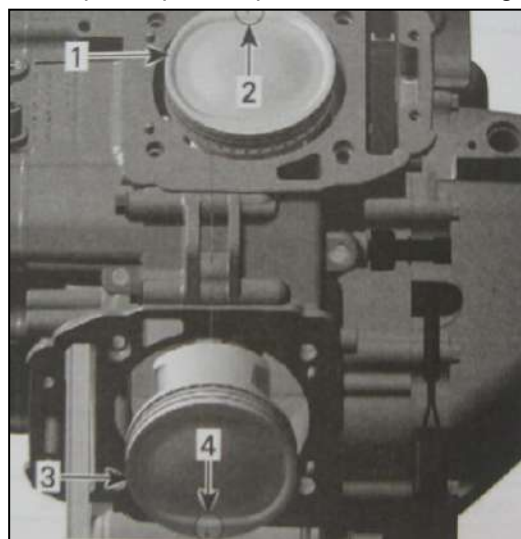

1. Piston of cylinder 1
2. Mark on piston must show to exhaust side of cylinder 1
3. Piston of cylinder 2
4. Mark on piston must show to exhaust side of cylinder 2

CAUTION: Take care that pistons will be installed with the punched arrow on piston top direction to the rear side of the engine.

Front cylinder: Mark on top of piston must show to intake side.

Rear cylinder: Mark on top of piston must show to exhaust side.

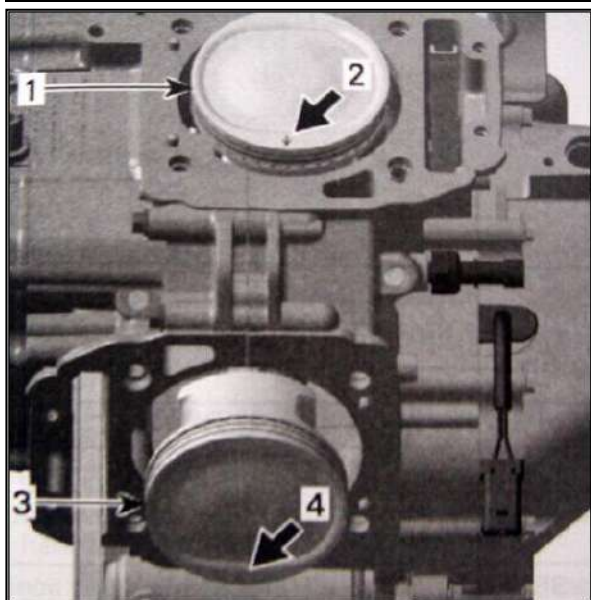

1. Piston of cylinder 1
2. Mark on piston must show to intake side of cylinder 1
3. Piston of cylinder 2
4. Mark on piston must show to exhaust side of cylinder 2

CAUTION: Always replace disassembled piston circlip(s) by new ones. Place a rag on cylinder base to avoid dropping the circlip inside the engine.

NOTE: Take care that the hook of the piston circlip is positioned properly.



3.13 PISTON RINGS

Ring Removal

Remove:

- Cylinder head
- Cylinder
- Piston pin.

Ring Inspection

Ring/piston Groove Clearance

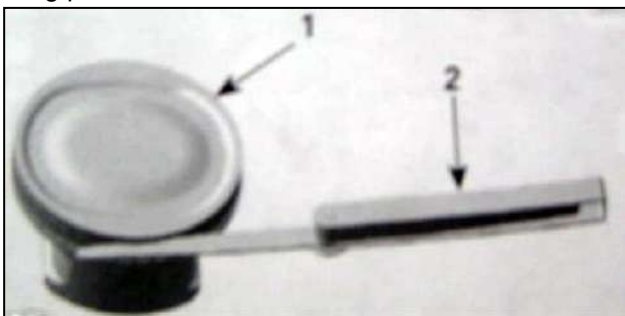

1. Piston
2. Feeler gauge

Using a feeler gauge measure each ring/piston groove clearance. If the clearance is too large, the

piston and the piston rings should be replaced.

Ring/piston groove clearance	
Upper compression ring	
New	0.030 to 0.070 mm
Service limit	0.150 mm
Lower compression ring	
New	0.020 to 0.060 mm
Service limit	0.150 mm
Oil scraper ring	
New	0.010 to 0.045 mm
Service limit	0.150 mm

Ring end gap	
Upper compression ring	
New	0.25 to 0.40 mm
Service limit	1.50 mm
Lower compression ring	
New	0.35 to 0.50 mm
Service limit	1.50 mm
Oil scraper ring	
New	0.20 to 0.70 mm
Service limit	1.50 mm

To measure the ring end gap, place the ring in the cylinder in the area of 8 to 16 mm from top of cylinder.

NOTE: In order to correctly position the ring in the cylinder, use piston as a pusher.

Using a feeler gauge, check ring end gap. Replace ring if gap exceeds above described specified tolerance.

Ring Installation

For installation, reverse the removal procedure. Pay attention to the following details.

NOTE: First install spring and then rings of oil scraper ring. Install the oil scraper ring first, then the lower compression ring with the word "N and TOP" facing up, then the upper compression ring with the word "N and TOP" facing up.

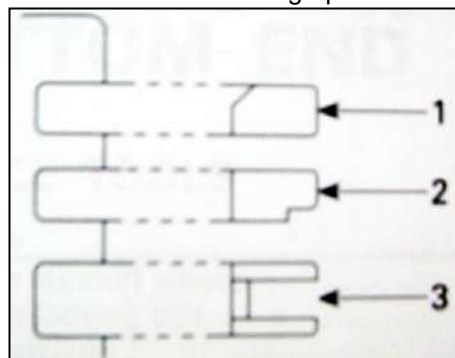

1. Upper compression ring
2. Lower compression ring
3. Oil scraper

CAUTION: Ensure that top and second rings are not interchanged.

NOTE: Use a ring expander to prevent breakage during installation. The oil ring must be installed by hand.

Check that rings rotate smoothly after installation. Space the piston ring end gaps 120 apart and do not align the gaps with the piston pin bore or the thrust side axis.

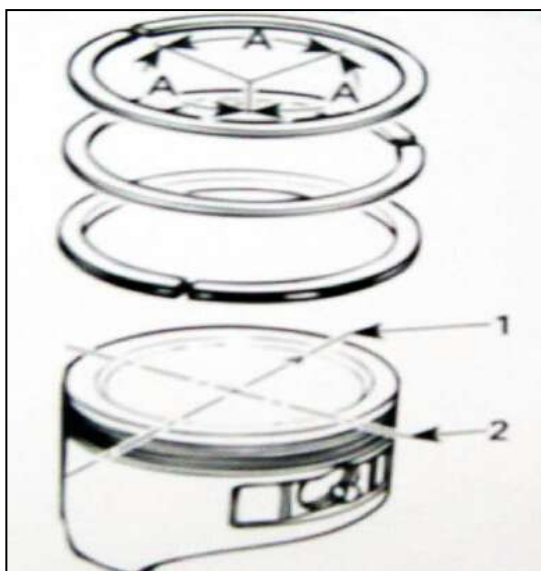

1. DO NOT align gap with piston thrust side axis
 2. DO NOT align ring with piston pin bore axis
- A. 120°.

3.14 DRIVE SHAFT

Oil Seal Removal

To remove the front oil seal, no need to remove the engine. Lift the front of vehicle to avoid engine oil spillage. Separate the front propeller shaft from engine.

For the rear oil seal, the gearbox removal is necessary.

Engine Drive Shaft Removal

NOTE: The engine drive shaft is located inside the engine and comes through it to drive the front differential.

Separate gearbox from engine.

To the rear of engine, remove the bearing cover and its O-ring.

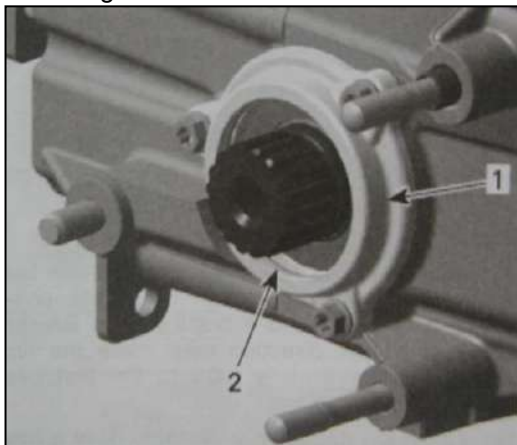

1. Bearing cover
2. O-ring

Pull out drive shaft.

CAUTION: check ends of the circlip for sharp edges or burr before removing the drive shaft, to avoid damaging the oil seal.

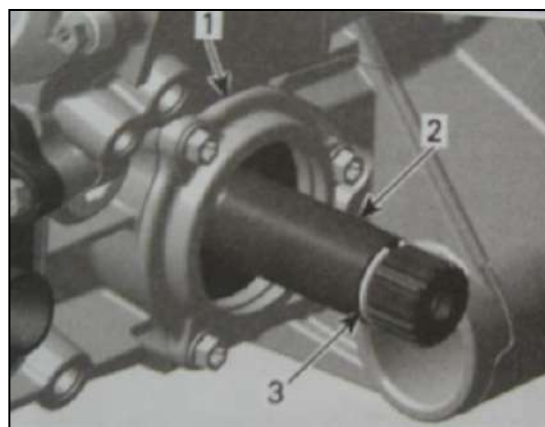

1. Bearing cover gearbox side
2. Drive shaft
3. Circlip

Remove the other bearing cover at the front of engine.

Engine Drive Shaft Inspection

Replace oil seals and/or O-ring if they are brittle, hard or damaged.

Check drive shaft bearings for contamination and/or metal shavings. Check if bearings turn freely and smoothly. Replace if necessary.

Check drive shaft for cracks, bend, pitting or other visible damages.

Check drive shaft splines for wear or damages.

Check oil seal running surface of the drive shaft for scratches. Replace if necessary.

Engine Drive Shaft Installation

The installation is reverse of removal procedure. Pay attention to the following details.

Clean all metal components in a solvent.

Crankcase surface and bearing covers are best cleaned using a combination of LOCTITE chisel and a brass brush. Brush a first pass in one direction then makes the final brushing perpendicularly (90°) to the first pass cross (hatch).

CAUTION: Do not wipe with rags. Use a new clean hand towel only.

Then install drive shaft oils with the oil seal installer. Use a suitable installer for installing bearings. Use LOCTITE 5910 on mating surfaces.

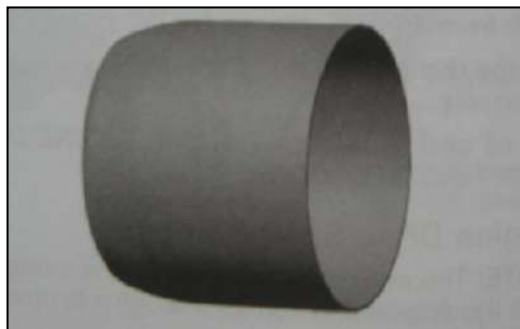

IMPORTANT: When beginning the application of the bearing cover sealant, the assembly and the first torquing should be done within 10 minutes. It is suggested to have you need on hand to save time. Use a plexiglass plate and apply some sealant on it. Use a soft rubber roller (50-75 mm) available in arts products suppliers for printing, and roll the sealant to get a thin uniform coat on the plate (spread as necessary). When ready, apply the sealant on bearing cover surfaces.

Do not apply in excess as it will spread out inside crankcase.

NOTE: It is recommended to apply this specific sealant as described here to get a uniform application without lumps. If you do not use the roller method, you may use your finger to uniformly distribute the sealant (using a finger will not affect the adhesion).

To install bearing cover, fit oil seal protection sleeve into oil seal.

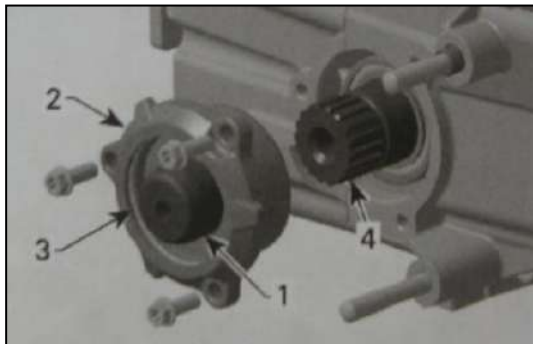

1. Protection sleeve
2. Bearing cover
3. O-ring
4. Drive shaft

Install bearing cover then place O-ring inside cover. Finally check for axial play of the drive shaft.

3.15 PTO COVER

Cover Removal

Remove

- CVT and air guide. Refer to TRANSMISSION
- Disconnect vent hose
- PTO cover screws and pull PTO cover.

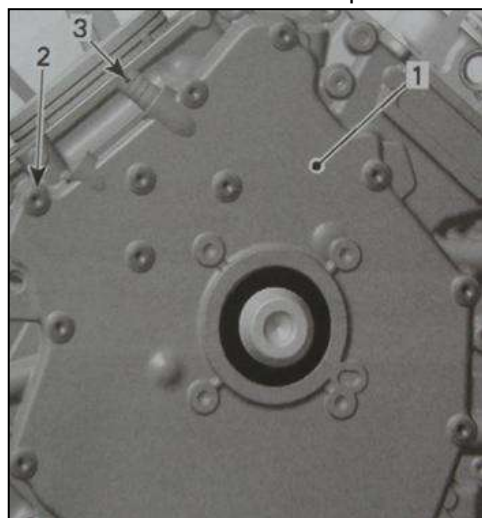

1. PTO cover
2. PTO cover screws
3. Vent hose nipple

Cover Inspection

Check the PTO cover for cracks or other damage.

Replace PTO cover if damaged.

Clean oil breather bore in PTO cover from contaminations with part cleaner then use an air gun to dry it.



1. Oil breather bore

Check oil seal running surface of crankshaft PTO side for grooves. Replace if necessary.

Oil Seal Installation

The installation is the reverse of the removal procedure.

Pay attention to the following details.

CAUTION: Oil seal must be installed with sealing lip toward the engine.

Push oil seal in place by using the oil seal installer.

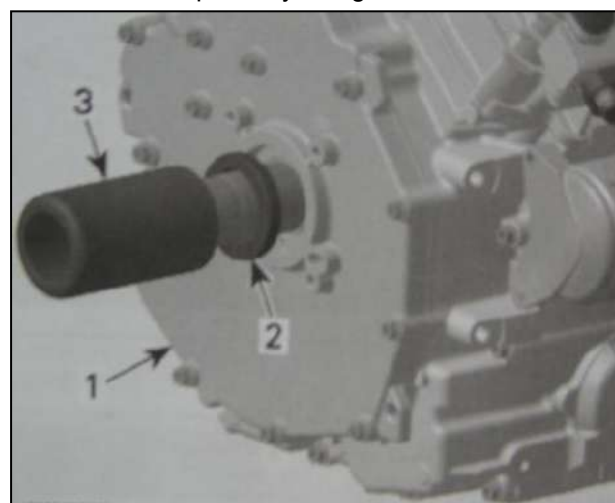

1. PTO cover
2. Oil seal
3. Oil seal installer

Check plain bearings for scorings or other damages.

NOTE: Measure plain bearing inside diameter and compare to crankshaft journal diameter (PTO support bearing). Refer to CRANKSHAFT in this section. Replace if the measurement is out of specification.

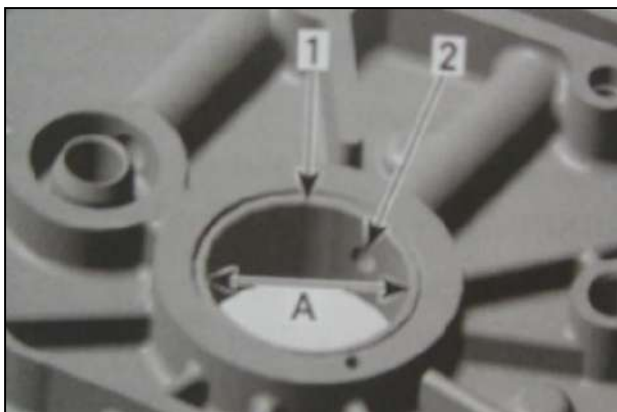

1. Plain bearing
2. Oil bore
- A. Measure plain bearing inside diameter

Plain bearing inside diameter
(PTO side support bearing)

Service limit	34.080 mm
---------------	-----------

Plain Bearing Replacement Procedure

Plain Bearing Removal

Carefully remove the oil seal no. 9 with a screwdriver, without damaging the PTO cover.

Push out the plain bearings from the outside towards the inside using the plain bearing remover/installer.

The PTO cover has to be supported from below with suitable support with straight surface, in order to prevent damage of the sealing surface.

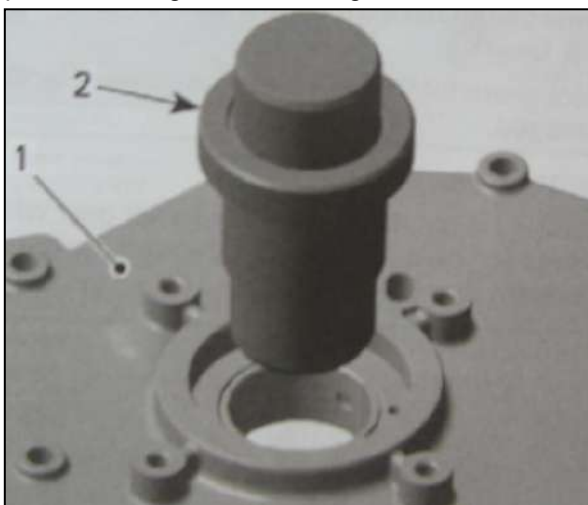

1. PTO cover
2. Plain bearing remover/installer

Plain Bearing Installation

CAUTION: Unless otherwise instructed, never use hammer to install plain bearings. Use press only. Install plain bearings with the proper plain bearing remover/installer in a cool PTO cover. Do not lubricate plain bearings and/or PTO cover for installation.

Carefully press-in the plain bearings in the same direction as during disassembly, from the outside towards the inside. Support PTO cover with suitable support with straight surface, in order to prevent damage of the sealing surface.

CAUTION: Mark position of oil bore on PTO cover and on plain bearing remover/installer. Align mark on plain bearing remover/installer with mark on PTO cover.

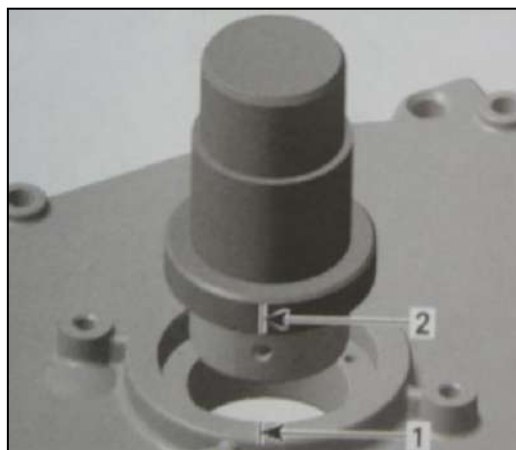

1. Mark position of oil bore on PTO cover
2. Mark position of oil bore on plain bearing remover/installer

NOTE: Wrong oil bore position will stop oil supply to plain bearings and will damage the engine.

CAUTION: The partition of the plain bearings must be positioned near to oil bore in counterclockwise direction.

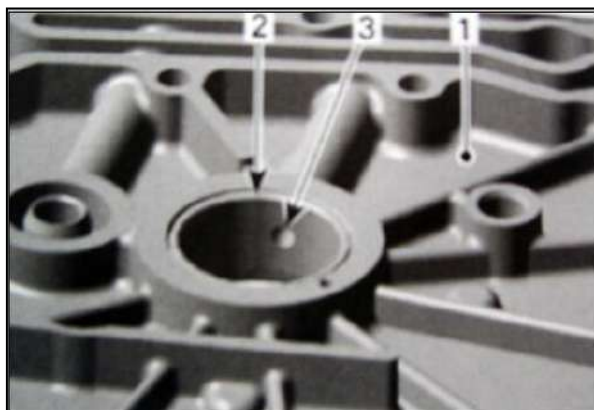

1. PTO cover (inside)
2. Partition
3. Oil bore

Cover Installation

For installation, reverse the removal procedure. Pay attention to the following details.

NOTE: At installation, replace PTO cover gasket and oil seal.

Tightening sequence for screws on PTO cover is as per following illustration.

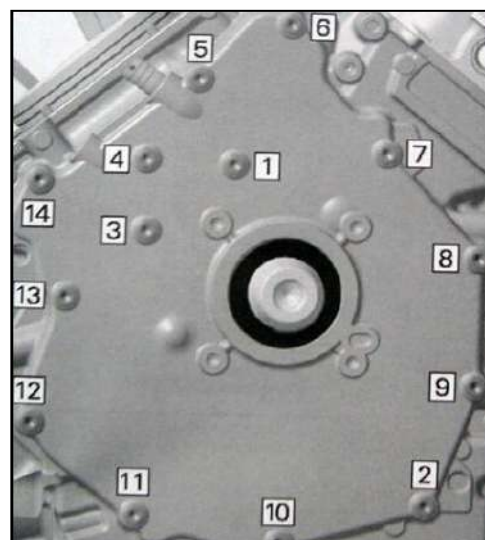

3.16 DRIVE GEARS

The drive gears are located on the engine PTO side behind the PTO cover.

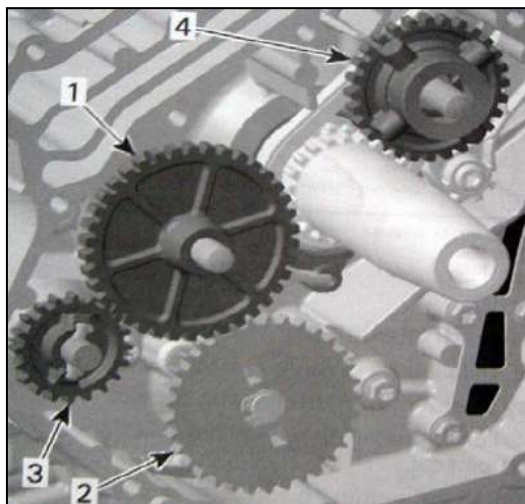

1. Intermediate gear
2. Oil pump gear
3. Water pump gear
4. Breather gear

Drive Gear Removal

Remove:

- PTO cover (refer to PTO COVER)
- Intermediate gear
- Oil pump gear
- Water pump gear

To remove water pump gear, pull the shaft assembly a bit out and turn it about one tooth until it stays out.

Now you can push water pump gear down. Remove needle pin and pull water pump gear out.

Remove breathe gear.

Drive Gear Inspection

Intermediate Gear/Oil Pump Gear/Water Pump Gear.

Inspect gears for wear or other damage. Replace if damaged.

Breather Gear

The engine is equipped with a breather gear which prevents engine oil coming out through the breathing system into the air box.

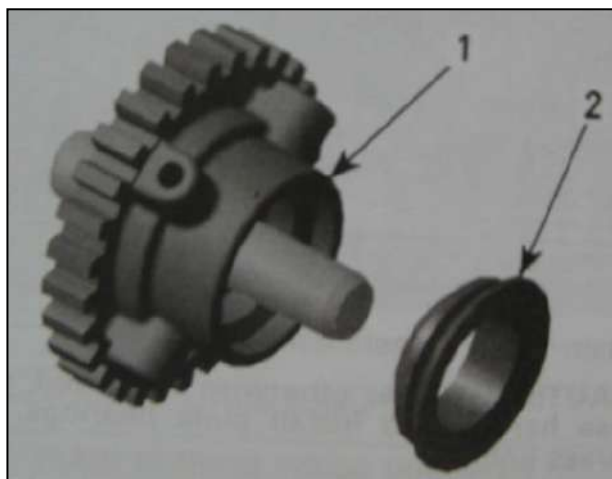

1. Breather gear
2. V-ring

Inspect gear for wear or other damage.

Check ball bearing for excessive play and smooth

operation. Replace breather gear assembly if necessary.

Drive Gear Installation

The installation is essential the reverse of the removal procedure, but pay attention to the following details.

NOTE: At installation replace the V-ring no. 16 of the breather gear.

Adequately oil the ball bearing of the breather gear.

3.17 TIMING CHAIN

The engine is equipped with two timing chains. One of the timing chains is located on engine MAG side behind the magnet cover. The second timing chain is located on engine PTO side behind the PTO cover.

Removal of Magneto Side Timing Chain

Remove:

- Valve cover, chain tensioner and camshaft timing gear (refer to CYLINDER AND HEAD)
- Magneto cover and rotor (refer to MAGNETO SYSTEM)
- Timing chain guide and lower timing chain guide.

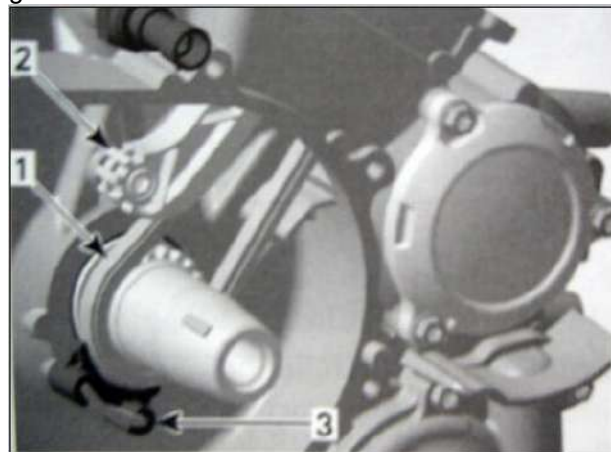

1. Timing chain
2. Timing chain guide
3. Lower timing chain guide

Carefully pull the timing chain sideward and down from the crankcase.

NOTE: Mark the operating direction of the timing chain before removal.

Removal of PTO Side Timing Chain

Remove:

- Valve cover, chain tensioner and camshaft timing gear (refer to CYLINDER AND HEAD section)
- PTO cover (refer to PTO COVER)
- Intermediate gear and breather gear (refer to DRIVE GEARS)
- Timing chain guide and lower timing chain guide (see illustration above).

Carefully pull the timing chain sideward and down from the crankcase.

NOTE: Mark the operating direction of the timing chain before removal.

Timing Chain Inspection

Inspection is the same for both timing chains.

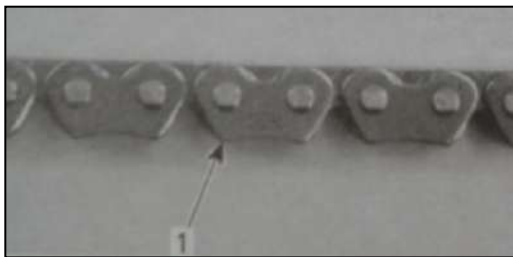

NOTE: Check timing chain on camshaft timing gear for excessive radial play. Check chain condition for wear and teeth condition. If chain is excessively worn or damaged, replace it as a set (camshaft timing gear and timing chain).

Timing Chain Installation

Installation is the same for both timing chains. The installation is essential the reverse of the removal procedure, but pay attention to the following details.

NOTE: Ensure to perform proper valve timing. Lock crankshaft (see CRANKSHAFT) and camshaft at TDC ignition (refer to CYLINDER AND HEAD section).

Install timing chain with camshaft timing gear then, adjust chain tension (refer to CYLINDER AND HEAD section).

CAUTION: Improper valve timing will damage engine components.

3.18 CRANKCASE

Crankcase Disassembly

Remove:

- Drive shaft (refer to ENGINE DRIVE SHAFT)
- PTO cover (refer to PTO COVER)
- Drive gears (refer to DRIVE GEARS)

NOTE: Oil pump removal from crankcase is not necessary, but recommended to see condition of oil pump (refer to LUBRICATION SYSTEM section).

- Electric starter

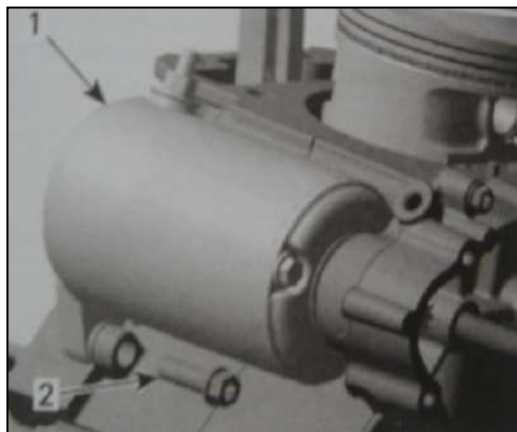

1. Electric starter
2. Screw

-Magneto cover and rotor (refer to MAGNETO SYSTEM section)

-Electric starter drive gears (refer to MAGNETO SYSTEM section)

-Water pump housing (refer to COOLING SYSTEM section)

-Oil filter (refer to LUBRICATION SYSTEM section)

-Cylinder head and cylinder (refer to CYLINDER AND CYLINDER HEAD section)

-Timing chains and timing chain guides (refer to TIMING CHAIN and TIMING CHAIN GUIDE).
Remove retaining screws of crankcase.

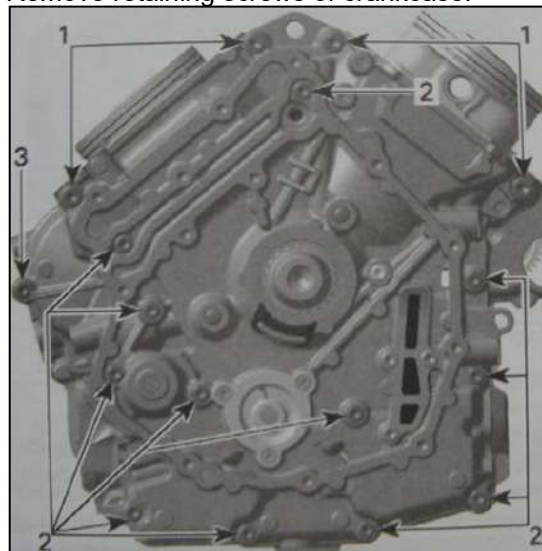

1. 4 screws M8 x 65
2. 12 screws M6 x 75
3. 1 screw M6 x 35

Carefully split crankcase halves by using a screw driver and a soft hammer.

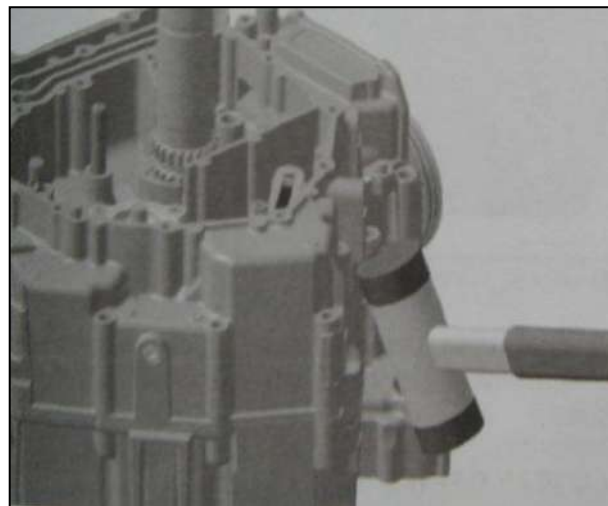

NOTE: During disassembly, do not damage the sealing surfaces of the crankcase halves.

Pull crankshaft out of crankcase.

Remove the water pump intermediate shaft and the water pump gear.



1. Water pump intermediate shaft
2. Water pump gear

Remove engine oil strainer.

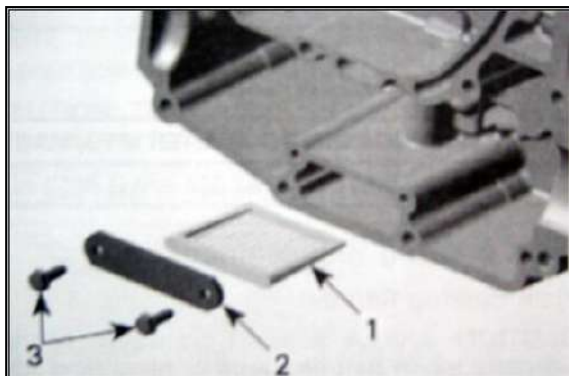

1. Engine oil strainer
2. Retaining plate
3. Screws

Crankcase Inspection

NOTE: Remove all remaining parts from the crankcase halves; they could get damaged during repair work.

Clean crankcase halves from contaminations and blow the oil supply lines with compressed air.

Check crankcase halves for cracks or other damage. Replace if damaged.

Check plain bearings for scorings or other damages.

NOTE: Measure plain bearing inside diameter and compare to PTO/MAG side journal diameters of crankshaft (refer to CRANKSHAFT). Replace if the measurements are out of specification.

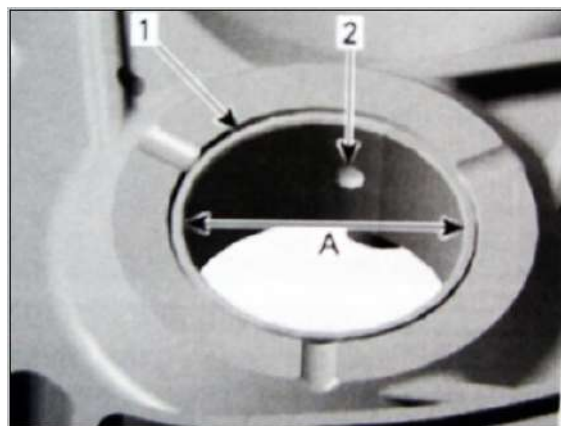

1. Plain bearing
 2. Oil bore
- A. measure plain bearing inside diameter

plain bearing inside diameter	
service limit	42.070 mm

Plain Bearing Replacement

Plain bearing Removal

CAUTION: Always support crankcase halves properly when ball bearing or plain bearings are removed. Damages to crankcase halves may occur if this procedure is not performed correctly.

NOTE: Always use a press for removal of plain bearings.

Remove plain bearings with the proper plain bearing remover/installer.

Carefully push the plain bearings out, from the crankcase half inside towards the outside.



NOTE: Place the proper crankcase support sleeve under crankcase halves before removing plain bearings. During disassembly, make sure not to damage the surfaces of the crankcase halves.

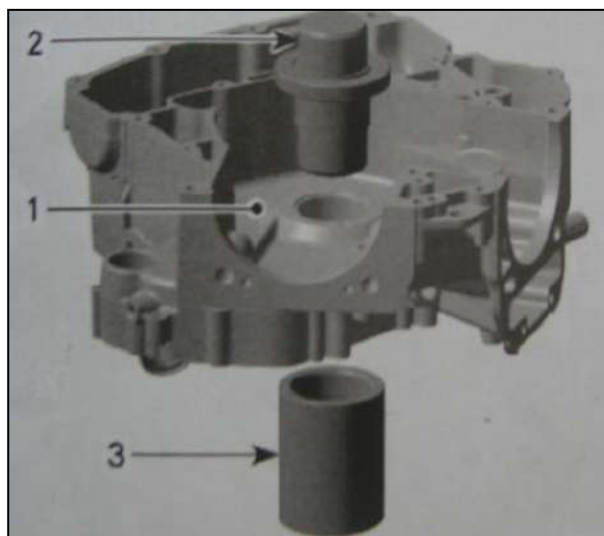

1. Crankcase half
2. Plain bear remover/installer
3. Crankcase support sleeve

Plain Bearing Installation

CAUTION: Unless otherwise, instructed, never use hammer to install ball bearings or plain bearings. Use press only.

Install plain bearings with the proper plain bearing remover/installer in a cool crankcase. Do not lubricate plain bearings and/or crankcase for installation.

NOTE: Place the proper crankcase support sleeve under crankcase halves before installing the plain bearings.

Carefully press-in the plain bearings in the same direction as during disassembly, from the crankcase inside toward the outside.

During reassembly, make sure not to damage the sealing surface of the crankcase halves.

CAUTION: Mark position of oil bore on crankcase half and on plain bearing remover/installer. Align mark on plain bearing remover/installer with mark on crankcase half.

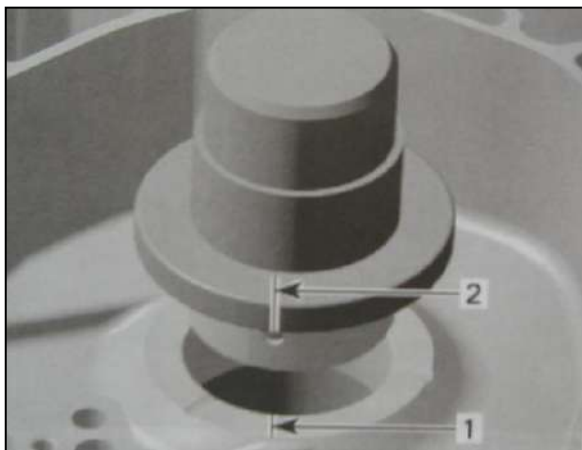

1. Oil bore position marked on crankcase
2. Oil bore position marked on plain bearing remover/installer

NOTE: Wrong oil bore position will stop oil supply to plain bearings and will cause engine damage.

CAUTION: the partition of the plain bearings in crankcase half MAG side must be positioned near to oil bore in clockwise direction (refer to no. 3 in next illustration).

CAUTION: The partition of the plain bearings in crankcase half PTO side must be positioned near to oil bore in counterclockwise direction (refer to no. 3 in next illustration).

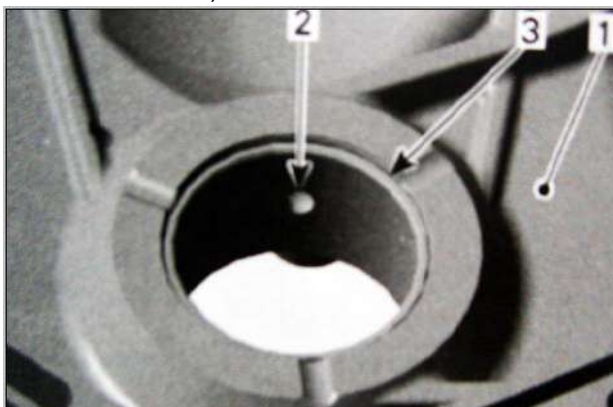

1. Crankcase half PTO (inside)
2. Oil bore
3. Partition

NOTE: Use an O-ring ($\phi 42 \times 1$ or 1.5 mm thickness) to hold plain bearings in place during installation. The O-ring will disappear in the groove, of the plain bearing remover/installer.

Crankcase Assembly

The assembly of crankcase is essentially the reverse of removal procedure. However, pay attention to the following details.

NOTE: Clean oil passages and make sure they are not clogged.

Clean all metal components in a solvent.

At installation, replace crankcase gasket.

Oil the plain bearings before mounting the crankshaft.

CAUTION: Correctly reinstall crankshaft (refer to

CRANKSHAFT).

Reinstall engine oil strainer.

Reinstall water pump shaft shafts /gears.

Tightening sequence for screws on crankcase is as per following illustration.

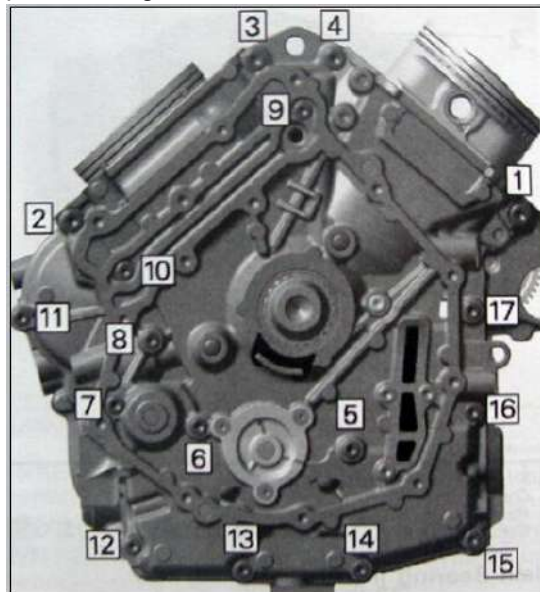

3.19 CRANKSHAFT

Crankshaft Removal

Refer to CRANKCASE.

Crankshaft Inspection

NOTE: Check each bearing journal of crankshaft for scoring, scuffing, cracks or other signs of wear.

NOTE: Replace crankshaft if the gears are worn or otherwise damaged.

CAUTION: Components with less than the service limit always has to be replaced. If this is not observed, severe damage may be caused to the engine.

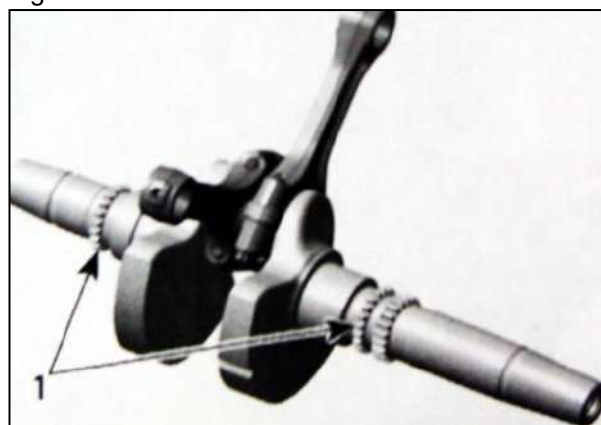

1. Crankshaft timing gears

Connecting Rod Big End Axial Play

Using a feeler gauge, measure distance between butting face of connecting rods and crankshaft counterweight. If the distance exceeds specified tolerance, replace the crankshaft.

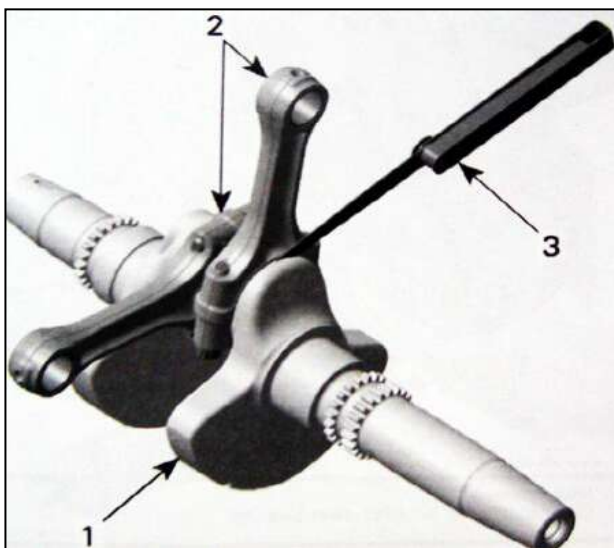

1. Crankshaft
2. Connecting rods
3. Feeler gauge

Connecting rod big end axial play	
New	0.200 to 0.500 mm
Service limit	0.6 mm

Connecting Rod/Piston Pin Clearance

NOTE: Prior to remove connecting rod from crankshaft, mark big end halves together to ensure a correct reinstallation (cracked surface fits in only one position).

Remove connecting rods from crankshaft.

CAUTION: Always replace connecting rod screws if removing the connecting rod. It is recommended to replace plain bearings, in case of installing the connecting rod.



1. Connecting rod screws.

Measure crankpin Compare to inside diameter of connecting rod big end.

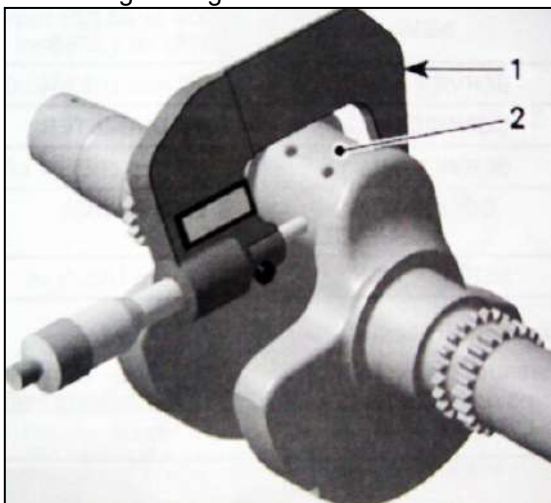

1. Micrometer
2. Crankpin area for plain bearing

To measure the rod big end diameter, use the OLD screws.

Install the OLD plain bearings as they were mounted initially.

Do the torque procedure as described further.

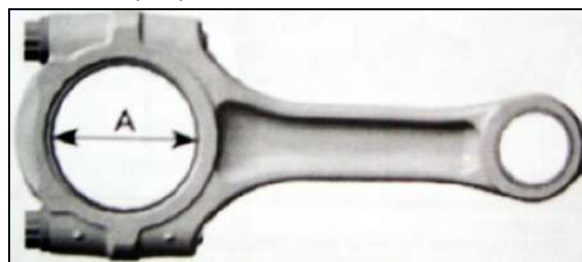

Crankshaft pin diameter	
new	40.009 to 40.025 mm
Service limit	39.990 mm
Connecting rod big end diameter	
Service limit	40.100 mm
Connecting rod big end radial clearance	
Service limit	0.09 mm

Crankshaft Radial Play MAG/PTO Side
Measure crankshaft on MAG/PTO side. Compare to inside diameter of MAG/PTO plain bearing (refer to CRANKCASE).

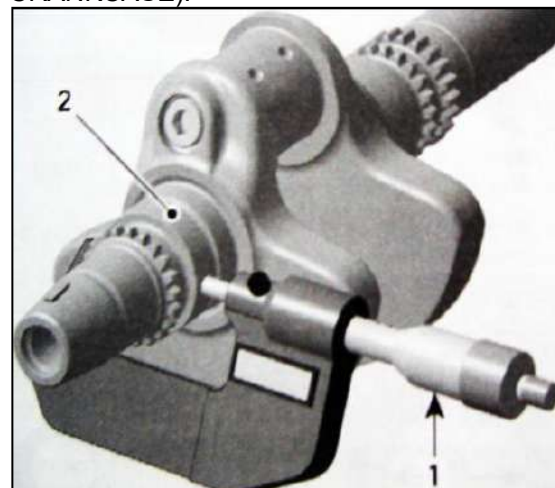

1. Micrometer
2. Crankshaft area for MAG plain bearing

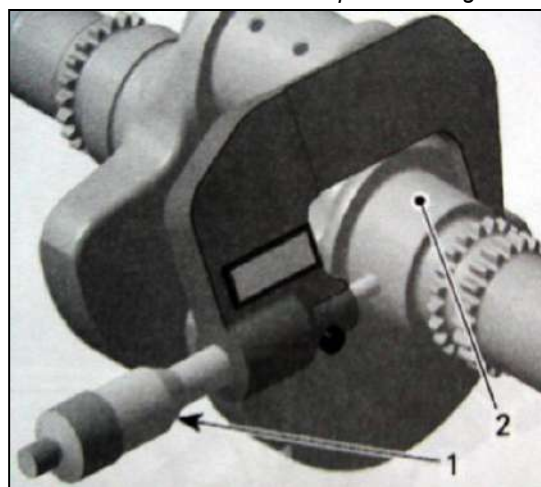

1. Micrometer
2. Crankshaft area for PTO plain bearing

Crankshaft main journal diameter	
New	42.024 to 42.040 mm
Service limit	42.000 mm
Crankshaft deflection	
Service limit	0.07mm
Crankshaft radial clearance	
Service limit	0.06 mm

Crankshaft Radial Play (PTO side support bearing)

Measure crankshaft journal of PTO support bearing. Compare to inside diameter of PTO support bearing in PTO cover (refer to PTO COVER).

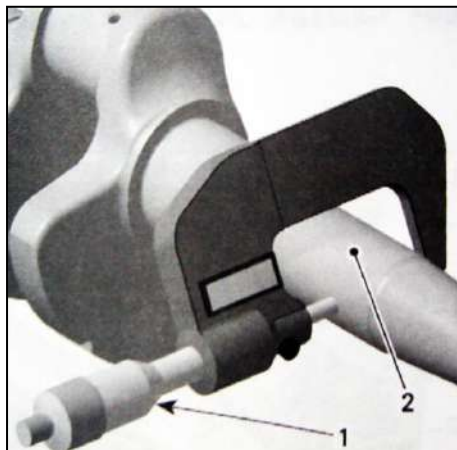

Crankshaft pin journal diameter (PTO support bearing)	
new	34.024 to 34.040 mm
Service limit	34.010mm
Crankshaft PTO support bearing radial clearance	
Service limit	0.01 mm

Crankshaft Assembly

For assembly, reverse the disassembly procedure. Pay attention to following details.

NOTE: Use NEW plain bearings, when connecting rod big end diameter is out of specification. Put plain bearings correctly in place and clean the split surface on both sides (cracked area) carefully with compressed air.

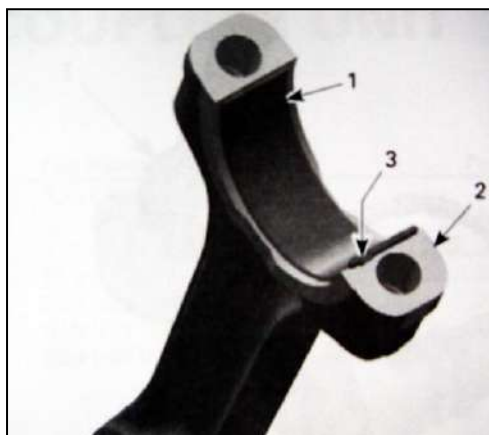

1. Half plain bearing of connecting rod big end
2. Split surface of the connecting rod
3. Nose of plain bearing in line with connecting rod groove

NOTE: Oil the plain bearing surface of the connecting rod and crank pin before installation. Torque NEW connecting rod screws as per

following procedure:

First, install screws with half of the recommended torque. Do not apply any thread locker.

Secondly, torque connecting rod screws to 20 Nm. Finish tightening the screws with an additional 60° turn using an angle torque wrench.

CAUTION: Failure to strictly follow this procedure may cause screw to loosen and lead to engine damage. The plain bearing tapered end must be against the counterweight. Besides, as the "crankpin" has been stretched from the previous installation, it is very important to use a new screw at assembly.

The running direction of big end bearings and of the piston pins must not change.

Crankshaft Installation

For installation of crankshaft in crankcase reverse the removal procedure. Pay attention to the following details.

CAUTION: Observe the correct installation position when fitting the crankshaft with the connecting rods. The connecting rod MAG side has to face to cylinder 1.

3.20 OIL PRESSURE REGULATOR

The oil pressure regulator is located the engine magneto side (inside magneto cover).



1. Engine pressure regulator

NOTE: The oil pressure regulator system works when the oil pressure exceeds 450kPa (65ps).

Removal

Remove plug screw and pull oil pressure regulator out.

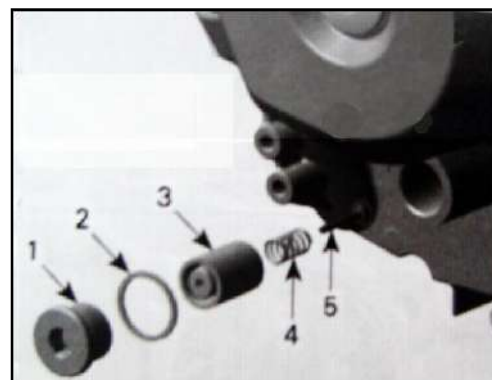

1. Plug screw
2. Gasket ring
3. Pressure regulator housing
4. Spring
5. Pressure regulator valve

Inspection

Inspect pressure regulator housing and valve for scoring or other damages.

Check spring for free length.

SPRING FREE LENGTH	
New nominal	39 mm (1.535 in)
Service limit	37 mm(1.457in)

NOTE: Replace worn or damaged components. Clean bore and thread in the magneto housing from metal shavings and other contaminations.

Installation

For installation, reverse the removal procedure.

Pay attention to the following details.

NOTE: At installation, always replace the gasket ring of the plug screw.

3.21 OIL PUMP

The oil pump is located on the engine PTO side (behind cover).

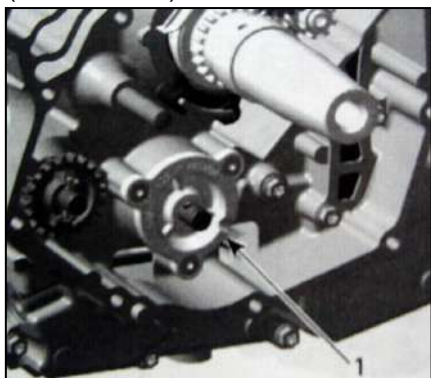

1. Oil pump

Removal

Remove parts to access the engine crankcase PTO cover.

Remove the engine crankcase PTO cover.

Remove:

- retaining ring
- oil pump gear
- needle pin
- thrust washer
- oil pump cover screws and pull oil pump cover
- oil pump shaft with inner rotor and outer rotor.

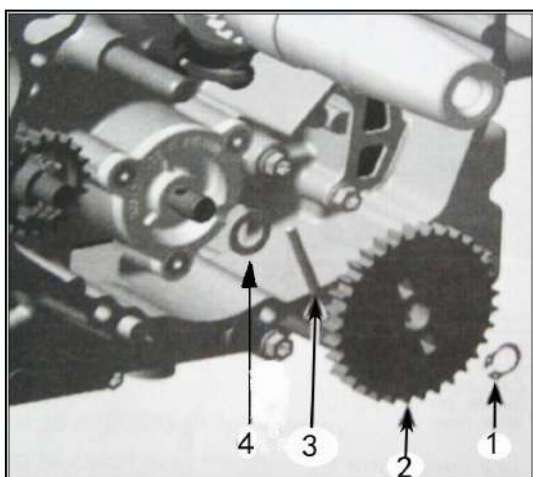

1. Retaining ring
 2. Oil pump gear
 3. Needle pin
 4. Thrust washer



1. Retaining screws
 2. Oil pump cover

Inspection

Inspect oil pump for marks or other damages.

Check for scratches in crankcase between outer rotor and oil pump bore. If so, replace damaged parts.



1. Oil pump bore
 2. Outer rotor
 3. Oil pump shaft
 4. Needle pin
 5. Inner rotor

Check inner rotor for corrosion pin holes or other damages. If so, replace oil pump shaft assembly.

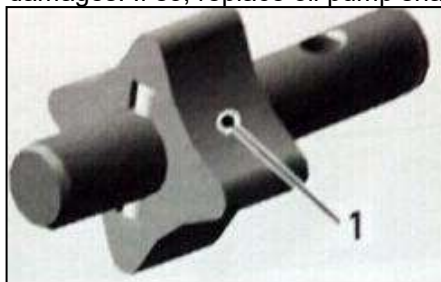

1. Pitting on the teeth

Using a feeler gauge, measure the clearance of inner and outer rotors as shown.

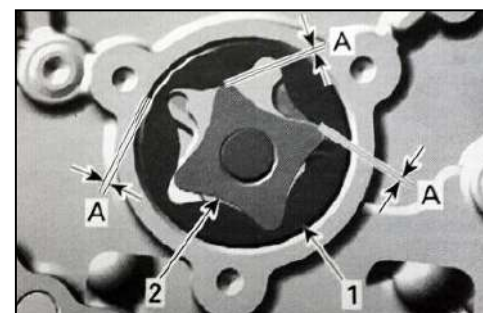

1. Outer rotor
 2. Inner rotor
 A. SERVICE LIMIT:0.25mm(0.09in)

If clearance of inner and outer rotors exceeds the tolerance, replace oil pump shaft assembly. Ensure to also check oil pump cover. If damaged, replace the complete oil pump assembly.

If clearance between outer rotor and its bore in crankcase exceeds the tolerance, replace the complete oil pump assembly and/ or the crankcase. Using a depth gauge, measure the axial clearance of the oil pump as shown.

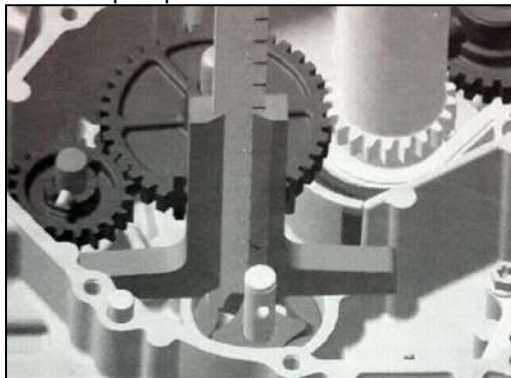

Oil PUMP-MEASUREMENT "A"

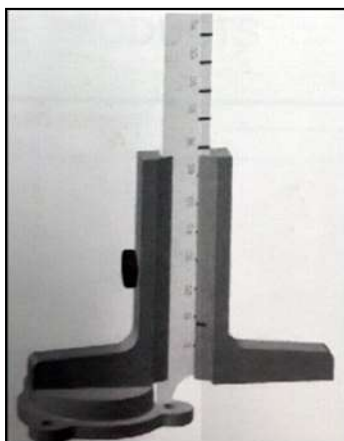

Oil PUMP COVER - MEASUREMENT "B"

Difference between measurements should not exceed 0.2 mm. If so, replace the complete oil pump assembly.

NOTE: When the axial clearance of the oil pump shaft assembly increases, the oil pressure decreases.

Installation

For installation, reverse the removal procedure. Pay attention to the following details.

NOTE: The outer rotor and inner rotor are marked. When installing, make sure both markings are on the upper side.

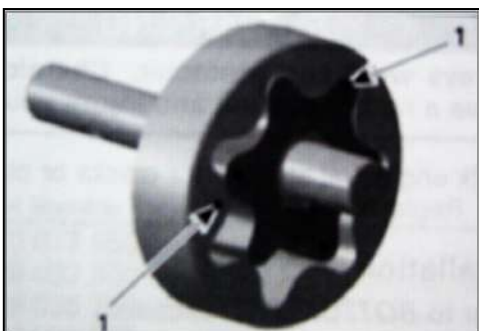

1. Markings

After reinstallation of the remaining parts, check for smooth operation of the oil pump assembly.

Final Test

After engine is completely reassembled, start engine and make sure oil pressure is within specifications.

3.22 MAGNETO COVER

Magneto Cover Removal

Lock crankshaft at TDC.

Drain engine oil.

Disconnect crankshaft position sensor (CPS) connector and cut tie rap.

Remove magneto cover retaining screws.

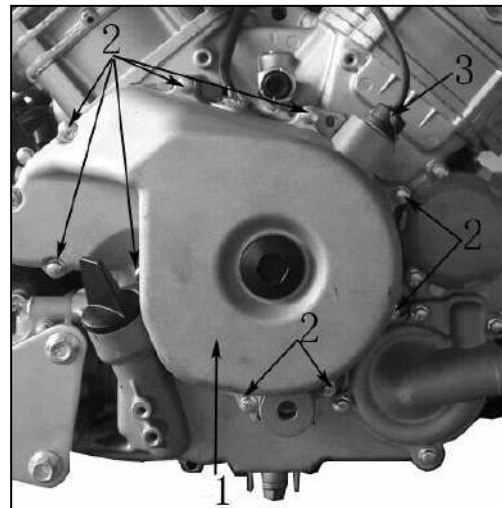

1. Magneto cover
2. Retaining screws
3. Crankshaft position sensor

Pull magneto cover.

Magneto Cover Inspection and Cleaning

Check magneto cover for cracks or other damage. Replace if necessary.

Magneto Cover Installation

For installation, reverse the removal procedure. However, pay attention to the following.

NOTE: At installation replace magneto cover gasket.

Apply Drei Bond sealing compound on stator cable grommet as shown in the illustration.

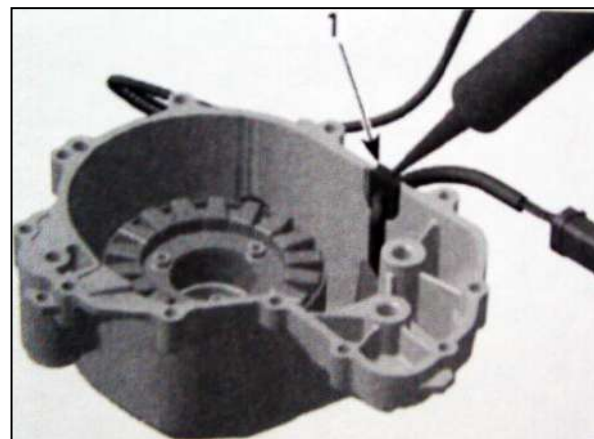

1. Apply drei bond sealing compound
- Tightening sequence for screws on magneto cover is as per following illustration.

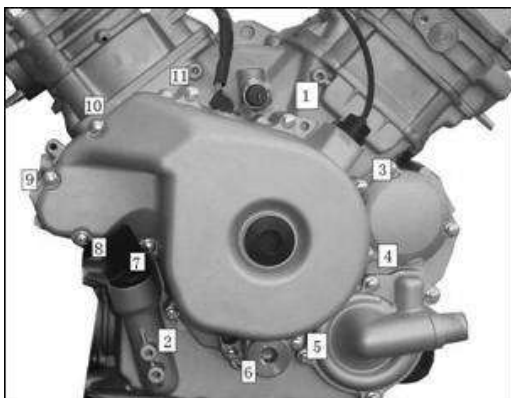

3.23 STATOR

Stator Removal

Remove magneto cover.
Remove screws securing holding strip.
Remove stator retaining screws then the stator.

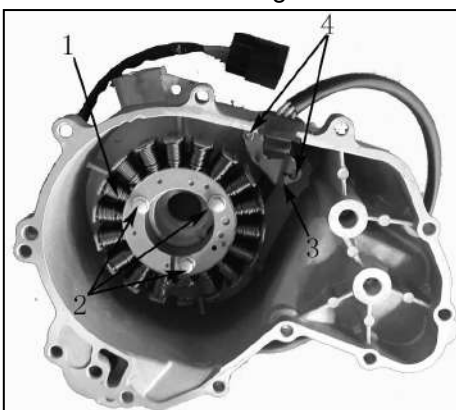

1. Stator
2. Stator retaining screws
3. Holding strip
4. Holding strip screws

Stator Inspection

Check stator condition. If damaged replace it.
Check if stator wires are brittle, bard or otherwise damaged.

For electrical inspection, refer to CHARGING SYSTEM.

Stator Installation

For installation, reverse the removal procedure.
However, pay attention to the following.

CAUTION: When installing the stator take care that the cable is in place (guide for wire).

NOTE: There is only one position for the stator (notch in the magneto housing cover).

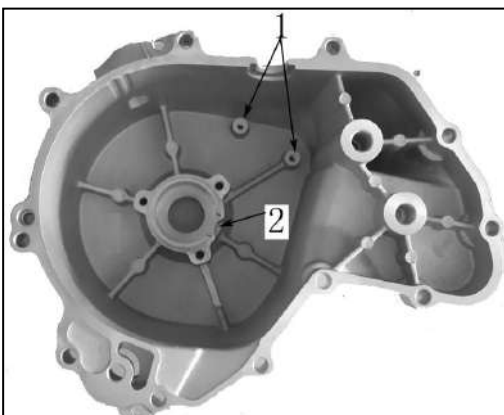

1. Threads for cable holding strip
2. Notch for stator

3.24 ROTOR

Rotor Removal

Lock crankshaft with crankshaft locking bolt.
Remove magneto cover. Refer to MAGNETO COVER above.

Remove screw and washer securing rotor to crankshaft.

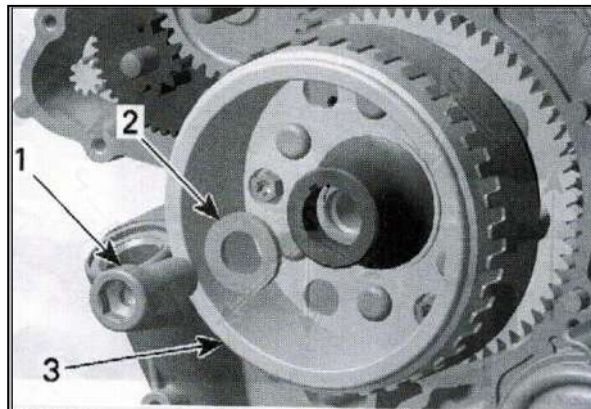

1. Screw M16
2. Washer
3. Rotor

Install magneto puller and crankshaft then remove rotor.

NOTE: Use grease to place protector on crankshaft end prior to screw on the magneto puller.

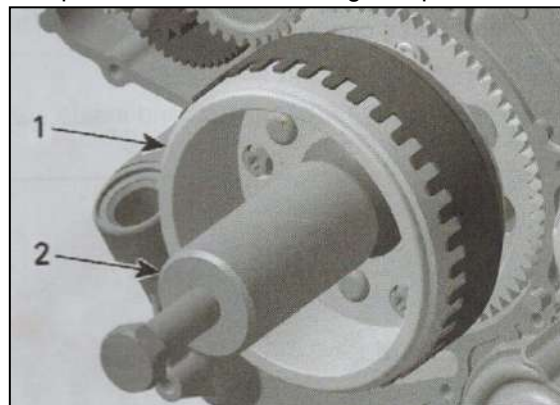

1. Rotor
2. Magneto puller

Screw magneto puller bolt to remove rotor.

Rotor Inspection

Check inner side of rotor for scratches or other damage.

Check keyway of the rotor for wear or damages.

Check if trigger wheel teeth are bent or otherwise damaged.



1. Rotor with trigger wheel

Check woodruff and keyway on the crankshaft for wear or damages.

Replace parts as necessary.

Rotor Installation

For installation, reverse the removal procedure. However, pay attention to the following.

Clean crankshaft taper and rotor with pulley flange cleaner.

CAUTION: Taper on crankshaft and rotor must be free of grease.

Oil sprag clutch in sprag clutch housing and install sprag clutch gear.

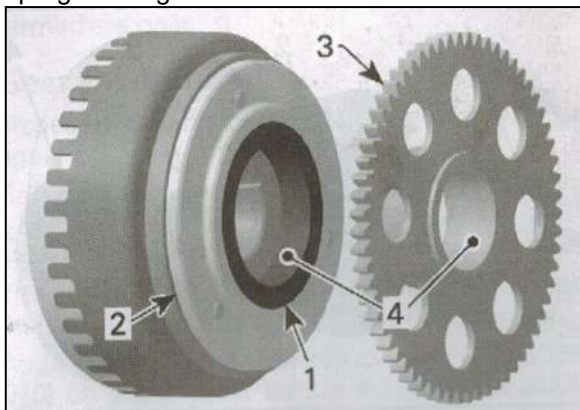

1. Sprag clutch
2. Sprag clutch housing
3. Sprag clutch gear
4. Apply engine oil here

Slide rotor onto crankshaft. The woodruff key and the keyway must be aligned.

Rotate starter double gear counterclockwise to align intermediate gear teeth with sprag clutch gear.

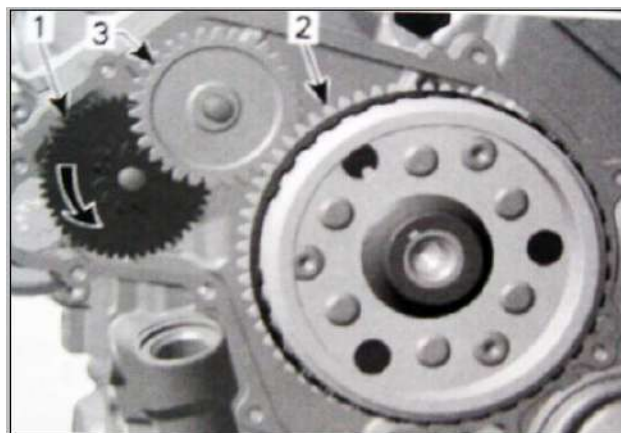

1. Starter double gear
2. Sprag clutch gear
3. Intermediate gear

3.25 SPRAG CLUTCH

Sprag Clutch Removal

Remove magneto cover

Loosen sprag clutch housing screws located inside rotor.

Remove rotor (refer to ROTOR above)

Remove sprag clutch gear.

Remove sprag clutch housing screws and sprag clutch housing.

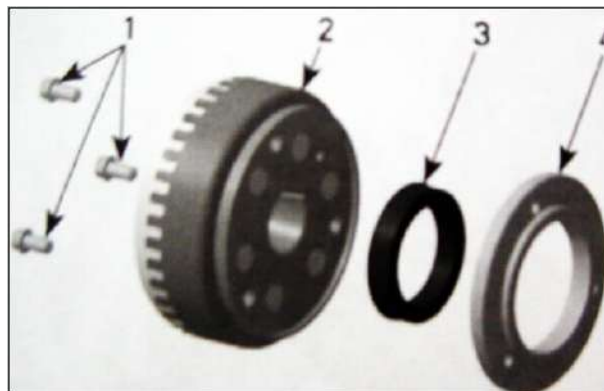

1. Sprag clutch housing screws
2. Rotor
3. Sprag clutch
4. Sprag clutch housing

Sprag Clutch Inspection

Inspect sprag clutch and sprag clutch housing for wear and damage.

Also check the collar of the sprag clutch gear.

Perform a functional test of the sprag clutch. To do so, rotate starter double gear counterclockwise in sprag clutch.

NOTE: Sprag clutch must lock in counterclockwise direction.



1. Lock

NOTE: Sprag clutch, housing and gear must be replaced at the same time, if damaged.

Sprag Clutch Installation

For installation, reverse the removal procedure. Pay attention to the following details.

Apply LOCTITE 648 (green) on threads of sprag clutch housing screws.

Install screw but do not torque yet.

Apply engine oil on sprag clutch and inside sprag clutch gear hole.

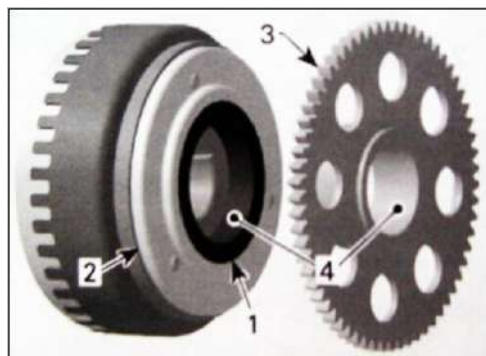

1. Sprag clutch
2. Sprag clutch housing

Install rotor then torque sprag clutch housing screws to 30 Nm.

3.26 SPRAG CLUTCH GEAR

Sprag Clutch Gear removal

Remove rotor.

Pull sprag clutch gear from rotor.

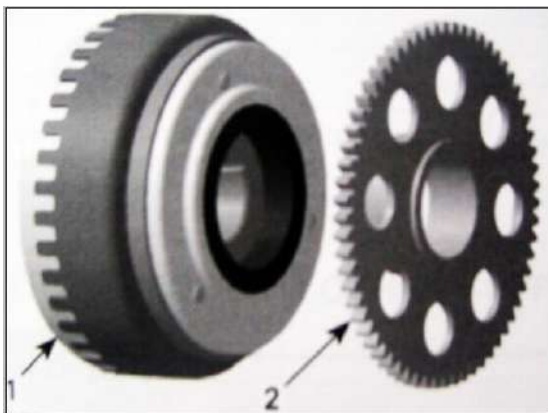

1. Rotor
2. Sprag clutch gear

Sprag Clutch Gear Inspection

Inspect gear, especially teeth and sprag clutch collar, for wear and other damage.

Check needle bearing condition. Replace sprag clutch gear if necessary.

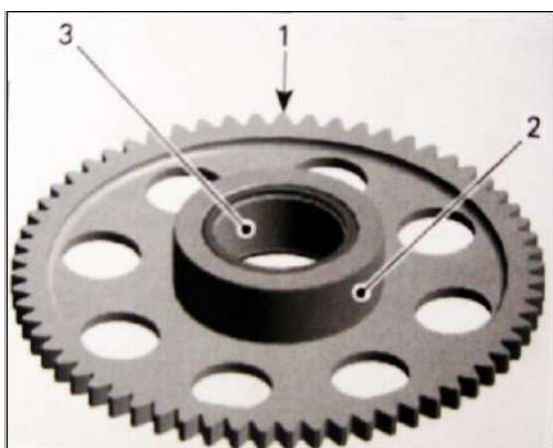

INSPECT

1. Teeth
2. Collar
3. Needle bearing

Sprag Clutch Gear Installation

The installation is the reverse of the removal procedure.

NOTE: Apply engine oil on needle bearing and collar of sprag clutch gear.

3.27 TRANSMISSION

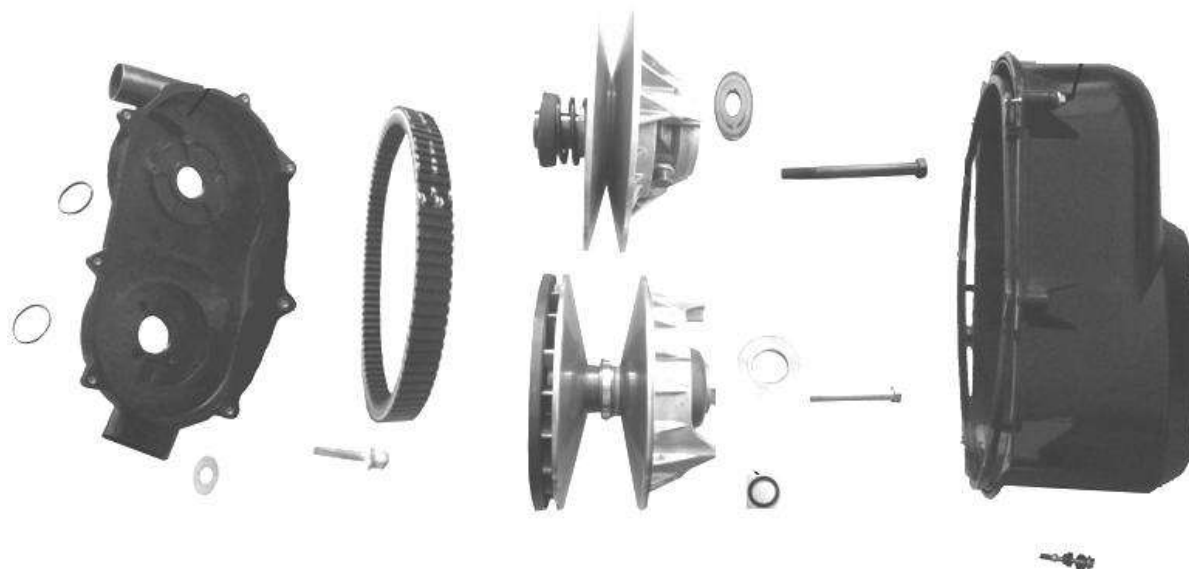

Never touch CVT while engine is running.
never drive vehicle when variator cover is removed.
Subcomponent installation and assembly tolerances require strict adherence to procedures detailed.

Never use any type of impact wrench at drive pulley removal and installation.

The clutch assembly is a precisely balanced unit.
Never replace parts with used parts from another clutch assembly

These pulleys have metric threads. Do not SAE threads puller. Always tighten puller by hand to ensure that the drive pulley has the same type of threads prior to fully tightening.

3.27.1 DRIVE BELT

Removal

Remove:

- Distance screws
- Remove variator cover and gasket.



1. Variator cover
2. Distance screw
3. Gasket

NOTE: Remove the center top screw last. This screw allows to support the cover during removal.

Open driven pulley with the driven pulley expander.



Screw tool in the threaded hole of driven pulley and tighten to open the pulley.

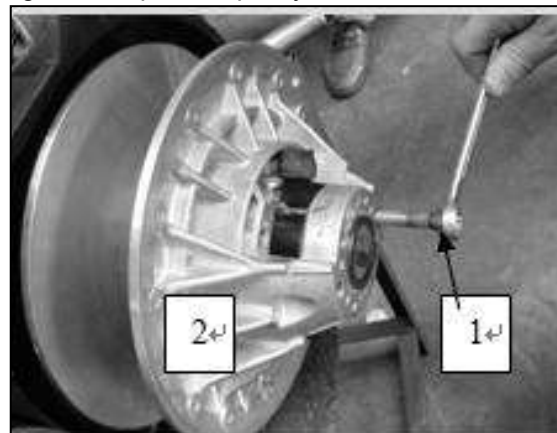

1. Driven pulley expander
2. Fixed sheave of driven pulley

To remove belt, slip the belt over the edge of fixed sheave as shown.

**INSPECTION**

Inspect belt for cracks, fraying or abnormal wear.
Replace if necessary.



Drive belt width	
Service limit	32.00mm (1.26 in)

Installation

For installation, reverse the removal procedure. Pay attention to following details.

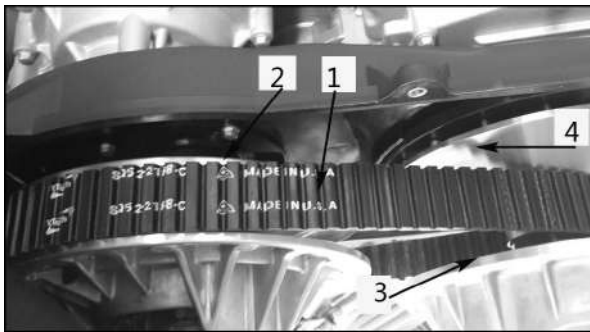

- 1. Word printed on belt
- 2. Drive pulley (front)
- 3. Driven pulley (rear)
- 4. Rotation direction

The maximum drive belt life span is obtained when the drive belt has the proper rotation direction. Install it so that the arrow printed on belt is pointing towards front of the vehicle, viewed from top.

Install variator cover gasket.

Install the center top screw in first.

Tighten the distance screw as per following sequence.

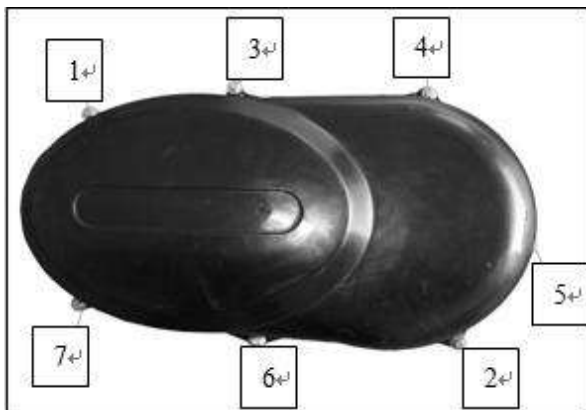

3.27.2 DRIVE PULLEY

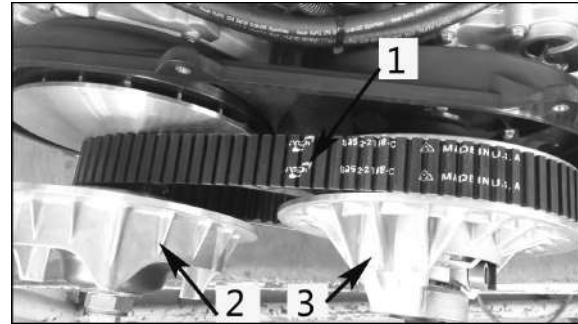

- 1. Belt
 - 2. Drive pulley
 - 3. Driven pulley
- Removal

- Remove variator cover and gasket.
- Remove belt

Block the drive pulley as followed.

Block drive pulley with the pulley holding tool.

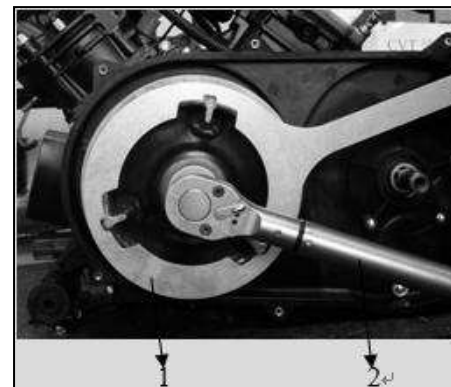
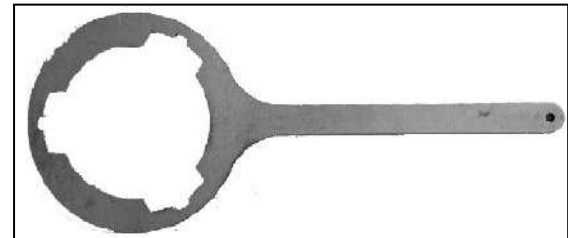

- 1. Pulley holding tool
- 2. Torque wrench

When the drive pulley is blocked, mark sliding sheave and governor cup to ensure correct reinstallation.

Unscrew the drive pulley screw (right hand thread), then remove it as well as the conical spring washer and thrust washer.

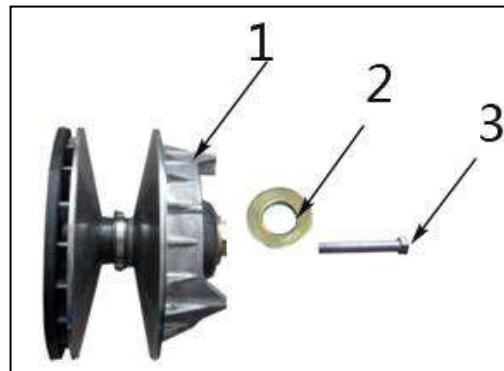

- 1. Drive pulley
- 2. Thrust washer
- 3. Drive pulley screw

Inspection

Drive pulley should be inspected annually for wear or damages.

Check drive pulley for cracks and sliding contact surface for excessive wear. Replace it if necessary. Check one-way clutch bearing for excessive play and smooth operation. Replace one-way clutch if necessary.

Installation

For installation, reverse the removal procedure. Pay attention to the following details.

Do not apply any lubricant on crankshaft and drive pulley tapers.

Clean pulley faces and shaft with dry cloth.

Install drive pulley on crankshaft extension.

Do not forget to place thrust washer.

Never substitute conical spring washer and/ or screw with jobber ones. Always use genuine parts for this particular case.

Install thrust washer with its concave side towards drive pulley then install drive pulley screw.

To torque the drive pulley screw, block the drive pulley. Refer at the beginning of this section.

When the drive pulley is blocked, torque screw to 100N•m.

3.27.3 DRIVEN PULLEY**Removal**

- Remove variator cover and gasket.
- Remove belt

Using the pulley holding tool, hold the driven pulley during the removal of the driven pulley screw, do not remove screw completely.



Put in tow STUD to Driven Pulley

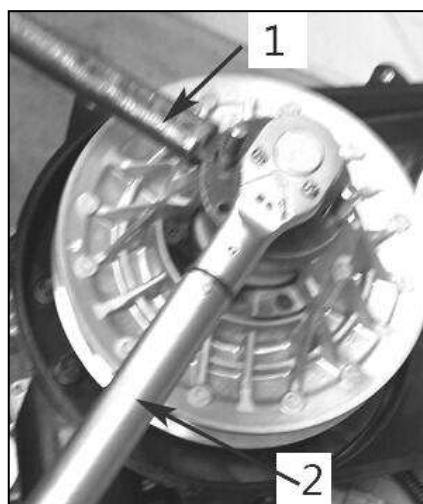

1. Driven Pulley holding tool

2. Torque wrench

When the driven pulley is blocked, unscrew the driven pulley screw.

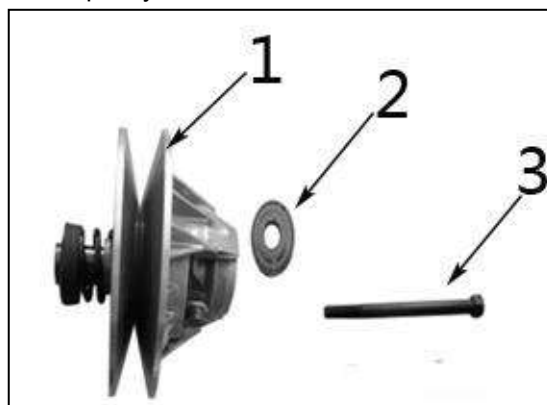

1. Driven pulley

2. Thrust washer

3. Driven pulley screw

Inspection

Driven pulley should be inspected annually for wear or damages.

Check sliding and fixed sheave for cracks and sliding contact surface for excessive wear. Replace sliding sheave if necessary.

Check sliding sheave bushings for cracks, scratch and for free movement when assembled to sliding sheave.

Check ball bearing for free play and smooth operation. Replace if necessary.

Installation

For installation, reverse the removal procedure. Pay attention to the following details.

Chamfer on inside diameter of the spacer must face engine side.

Clean pulley faces and shaft with dry cloth.

Driven pulley is a spring-loaded system.

Always place washer at the time of driven pulley installation.

When the driven pulley is blocked, torque screw to 60N•m.

3.27.4 CVT AIR GUIDE**Removal**

Remove:

- Variator cover
- Drive belt
- Drive pulley

-Driven pulley

Unscrew the clamps retaining the CVT air hoses
Remove CVT air guide.

Inspection

Clean CVT air guide from contamination.

Check O-rings if brittle, hard or damaged. Replace if necessary.

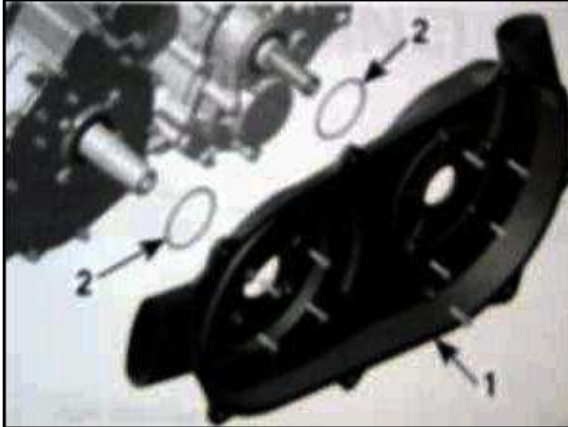

1. CVT air guide

2. O-rings

Installation

For installation, reverse the removal procedure.

3.28 GEARBOX

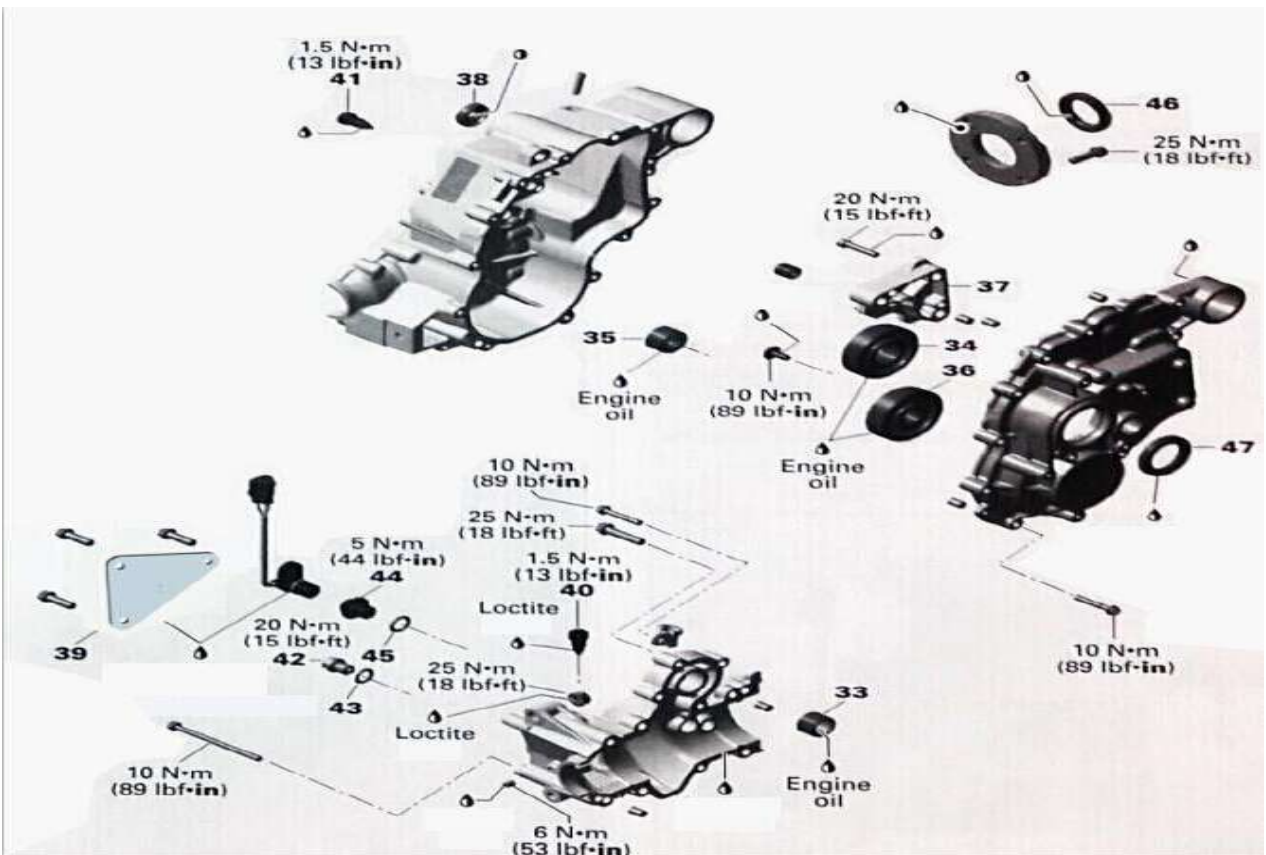
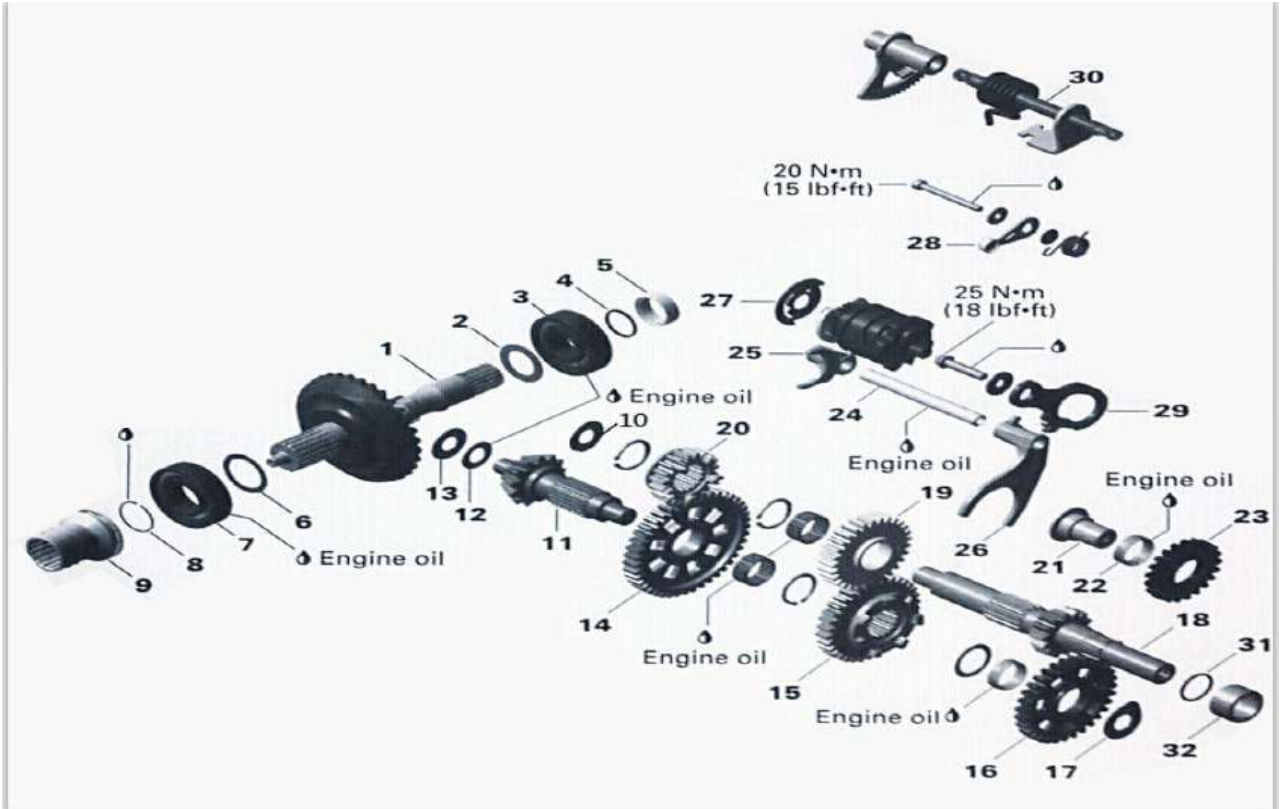

To remove gearbox, the engine removal is necessary. First remove drive and driven pulley and CVT air guide. After unscrew the three (3) nuts attach the gearbox to the engine. Then pull gearbox to separate it from engine. Always drain the gearbox oil before working on.

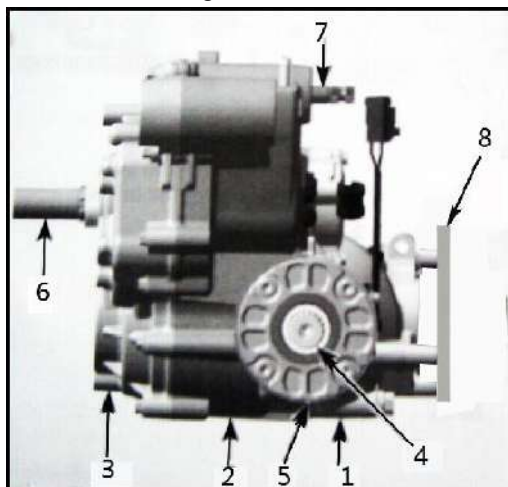

1. Right housing
2. Center housing
3. Left housing
4. Output shaft
5. Bearing cover
6. Countershaft
7. Shift shaft
8. Cover

3.28.1 GEARBOX OIL DRAIN

Prior to change the oil, ensure gearbox is on a level surface.

Place a drain pan under the gearbox drain plug area.

Clean drain plug area and remove magnetic drain plug with its sealing ring to drain gearbox oil.

Remove oil filler screw including its O-ring.

CAUTION: Pay attention not to lose O-ring on drain plug screw.

Wait a while to allow oil flow out of gearbox.

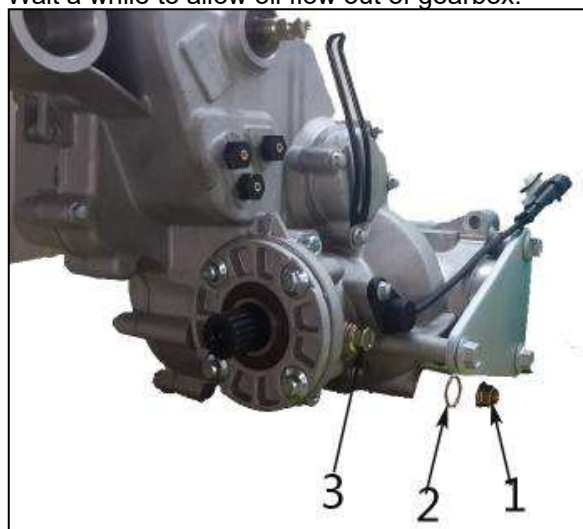

1. Magnetic drain plug
2. Sealing ring
3. Oil filler screw

Dispose gearbox oil as per your local environmental regulations.

Inspection

Oil condition gives information about the teeth

condition inside the gearbox.

Clean the magnetic drain plug from metal shavings and dirt. Presence of debris gives an indication of failure inside the gearbox. Check gearbox to correct problem.

Change gasket ring on the magnetic drain plug if damaged.

Replace O-ring if brittle, hard or otherwise damaged.

3.28.2 POSTION INDICATOR SWITCHES

NOTE: The gearbox removal is not necessary to reach the gearbox position indicator switches.

Removal

To reach the gearbox position indicator switches, remove the rear engine cover.

Remove screw retaining indicator switch wire.

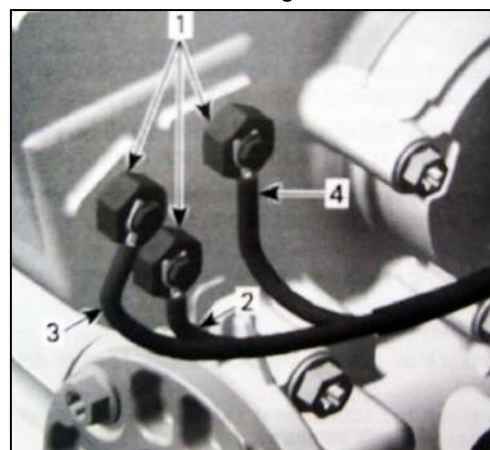

1. Gearbox position indicator switches
2. BROWN/ GREY wire
3. WHITE/ GREY wire
4. ORANGE/ GREY wire

Unscrew switch.

Test

Check if gearbox position indicator switches work properly as per following procedure:

NOTE: Remove insulating paint to obtain correct readings.

Put gearbox in park, reverse, neutral, high and low position.

Use a multi meter to measure the resistance from the indicator switch to engine ground. Compare results with the logic table below.

Shifter position	Corresponding switch wires		
	Brown/ grey	White/ grey	Orange/ grey
L	x		x
H			x
N		x	x
R		x	
P	x	x	

An "x" indicates switch is making ground contact, thus there should be continuity (R is close to 0 ohms)

A blank space indicates switch is not making contact, there should be no continuity (R = infinite). If the indicator switch is good, check the vehicle harness and /or indicator lights.

Installation

For installation, reverse the removal procedure.

Pay attention to the following details.
Take care do not damage shifting indicator switched threads during installation.
If all switches are removed, make sure to put the wires back in the right location.

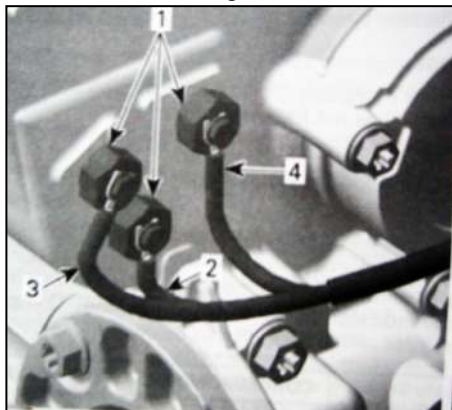

1. Gearbox position indicator switches
2. BROWN/ GREY wire
3. WHITE/ GREY wire
4. ORANGE/ GREY wire

Spray a layer of electrical insulating paint or varnish over switches to prevent shorts and corrosion.

3.28.3 OIL SEALS

Removal

Replace oil seals if they are brittle, hard or damaged.

A small flat screwdriver can be used to remove most of these oil seals.

CAUTION: Avoid scoring housings, bearing cover, shift shaft, distance sleeve of countershaft or output shaft during oil seal removal.

Countershaft oil seal

The countershaft oil seal can be removed without removing gearbox from vehicle. Remove drive and driven pulley and CVT air guide.

NOTE: When oil seal is removed also inspect O-ring

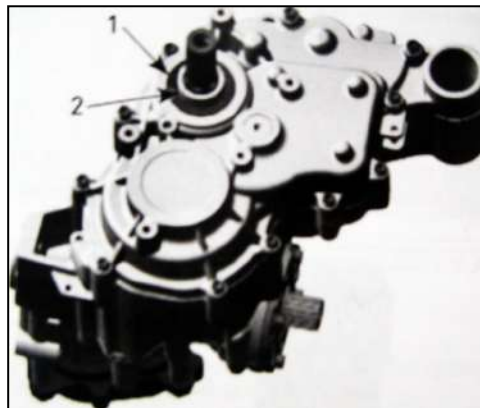

1. Countershaft oil seal
2. Distance sleeve

Shift shaft oil seal

The shift shaft oil seal can be removed without removing the gearbox from the vehicle.

Remove side panel and the shifting plate from shift shaft to reach the oil seal.

Output shaft oil seal

Removal of output shaft oil seal requires that the rear propeller shaft is separated from the output shaft. The removal of the gearbox or bearing cover is not necessary.

NOTE: When oil seal is removed also inspect O-ring

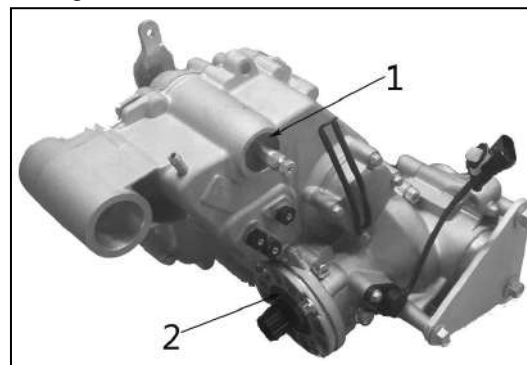

1. Shift oil seal
2. Output shaft oil seal

Inspection

Check bearings behind each oil seal for contamination and / or metal shavings.

Check oil seal running surfaces for scratches.

Replace if necessary.

Check if the countershaft O-ring and the output shaft O-ring are brittle, hard or damaged. Replace if necessary.

Installation

The installation is the reverse of removal procedure.

Pay attention to the following details.

Output shaft and countershaft oil seal

Install output shaft oil seal and countershaft oil seal with the oil seal installer.



1. Output shaft oil seal
2. Oil seal installer

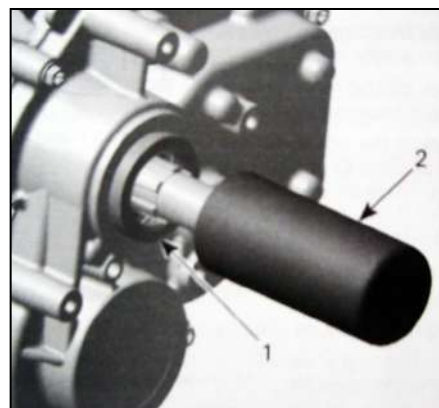

1. Countershaft oil seal
2. Oil seal installer

Shift shaft oil seal

Using a suitable tube with the proper diameter to install the shift shaft oil seal.

If gear housing is apart, the oil seal installer and installer handle can be used for shift shaft oil installation.

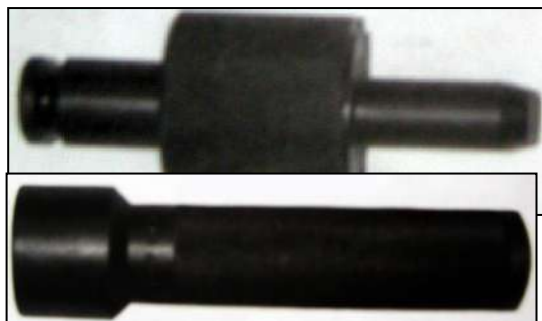

CUTION: Oil seal must be installed with sealing lip toward gearbox.

3.28.4 OUTPUT SHAFT

Remove gearbox.

Before removing the right housing and output shaft measure the back lash on output shaft. This measure will indicate if output shaft adjustment is necessary.

Output Shaft Back Lash Procedure

Engage PARK position on the gear shaft to block gearbox.

Remove:

-Bearing cover with oil seal

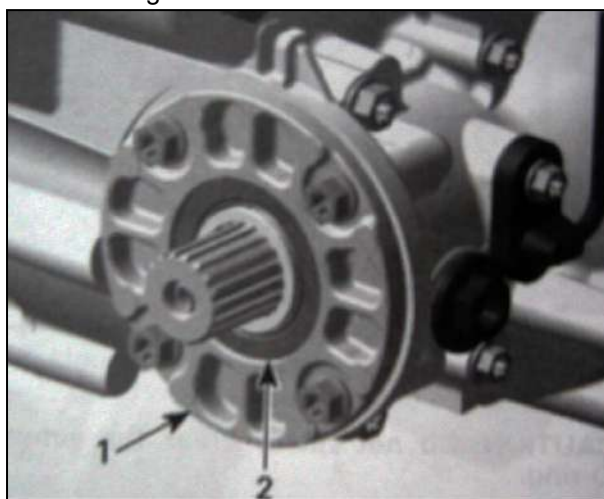

1. Bearing sleeve
2. Oil seal
 - Distance sleeve
 - O-ring

NOTE: It is recommended to apply this specific sealant as described here to get a uniform application without lumps. If you do not use the roller method, you may use your finger to uniformly distribute the sealant (using a finger will not affect the adhesion).

Install all the screws on right housing then the O-ring and the distance sleeve on end of output shaft. Chamfered bore of distance sleeve has to face the engine.

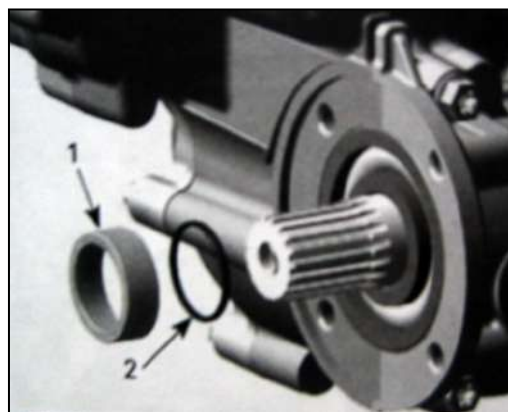

1. Distance sleeve
2. O-ring

Install the backlash measurement tool at the end of output shaft.

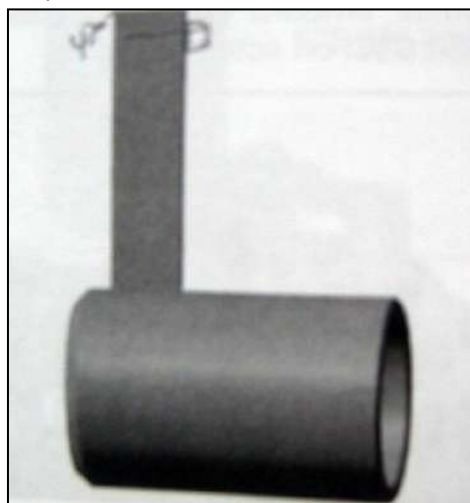

From center of tool bolt, measure 47 mm and place a mark on the tab.

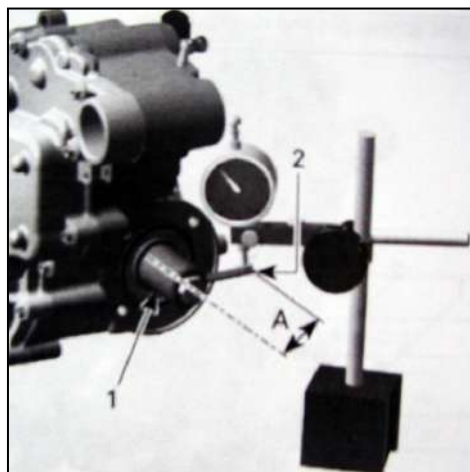

1. Back lash measurement tool
 2. Mark on tab
- A 47 mm

Position the head of the dial indicator, against the tab at a 90° angle and on the line. Then, gently rotate the output shaft.

This reading gives the backlash measurement.

Refer to the following table for backlash specifications.

Output shaft backlash	
New	0.10 to 0.20 mm
Service limit	0.25 mm

If back lash is not within the specification, remove the output shaft and select the next larger or smaller shim to meet the specifications.

NOTE: Use next larger shim to increase back lash and next small shim to reduce backlash.

Removal

Remove the bearing cover with oil seal.

Unscrew all bolts retaining the right housing to the center housing.

To remove right housing, use 2 big screwdrivers.

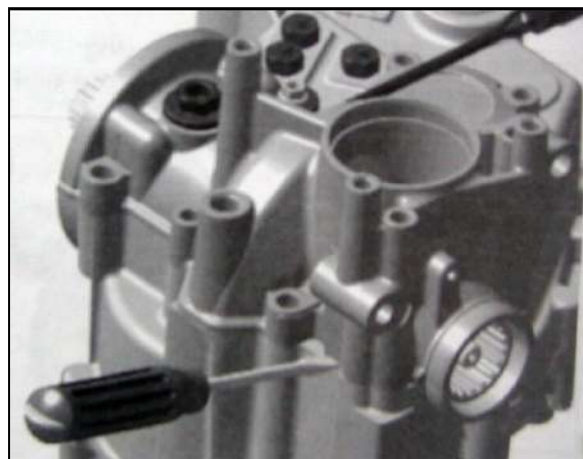
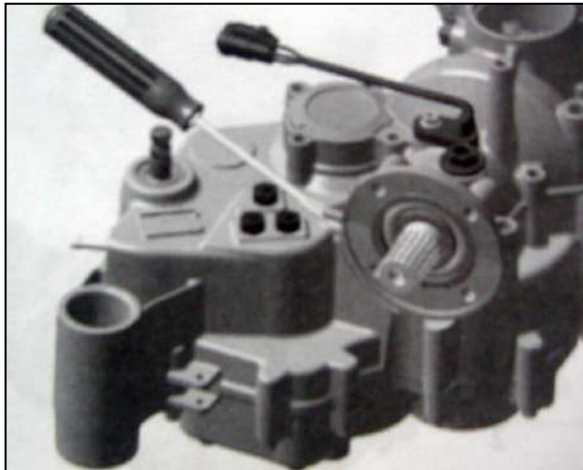

Remove output shaft.

CAUTION: Use a soft hammer to remove output shaft from center housing.

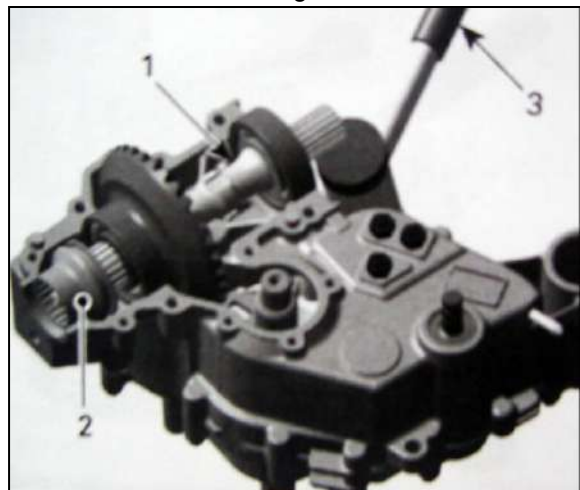

1. Output shaft
2. Coupling sleeve
3. Soft hammer

Continue removal procedure by removing:

-coupling sleeve, O-ring, ball bearing and shim.

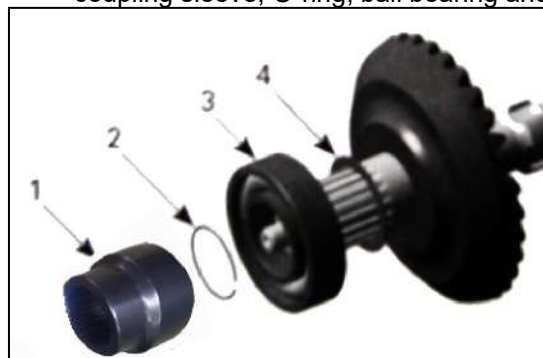

1. Coupling sleeve
2. O-ring
3. Ball bearing
4. Shim

-ball bearing and thrust washer

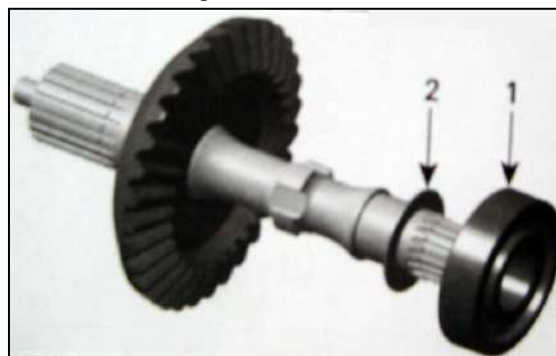

1. Ball bearing
2. Thrust washer

Inspection

Check output shaft and its gear for cracks, bend, pitting or other visible damages.

Check output shaft splines for wear or other damages.

CAUTION: Always replace output shaft and bevel gear shaft at the same time. Adjust these components upon replacement.

Check if the output shaft bearings and turn freely and smoothly. Replace if necessary.

Replace oil seal if brittle, hard or damaged.

Replace O-rings and if brittle, hard or damaged.

Check splines of coupling sleeve for wear or other damages.



1. Inspect splines

Installation

Install shim, bearing, O-ring and coupling sleeve onto the output shaft.

Install thrust washer and ball bearing.

O-ring and distance sleeve are not installed at this time.

Place the output shaft into the center housing.
Use soft hammer to put bearing exactly in place against center housing.

Clean the bearing cover location then attach bearing cover with oil seal to the housing.

Temporarily install the right housing with the four (4) M8 screws beside bearing seats.

NOTE: prior to tightening the screws, tap on the gear end of output shaft with a soft hammer to take up all gear free play.

Verify output shaft backlash. Refer to OUTPUT SHAFT BACK LASH PROCEDURE in this section. Adjust as required.

If back lash is with in specifications, remove dial indicator, backlash measuring tool, bearing cover and right housing.

Clean all metal components in a solvent.

Housing mating surfaces are best cleaned using a combination of chisel (gasket remover) and a brass brush. Brush a first pass in one direction then makes the final brushing perpendicularly (90°) to the first pass cross (hatch).

CAUTION: Do not wipe with rags. Use a new clean hand towel only.

Important: When beginning the application of sealant, the assembly and the first torquing should be done within 10 minutes. It is suggested to have all you need on hand to save time.

Use LOTITE 5910 on mating surfaces.

Use a plexiglass plate and apply some sealant on it. Use a soft rubber roller (50-75 mm), available in arts products suppliers for printing, and roll the sealant to get a thin uniform coat on the plate (spread as necessary). When ready, apply the sealant on housing mating surfaces.

Do not apply in excess as it will spread out inside housing.

NOTE: It is recommended to apply this specification without lumps. If you do not use the roller method, you may use your finger to uniformly distribute the sealant (using a finger will not affect the adhesion). Install all other screws on right housing then the O-ring no. 4 and the distance sleeve on end of output shaft. Chamfered bore of distance sleeve has to face the engine.

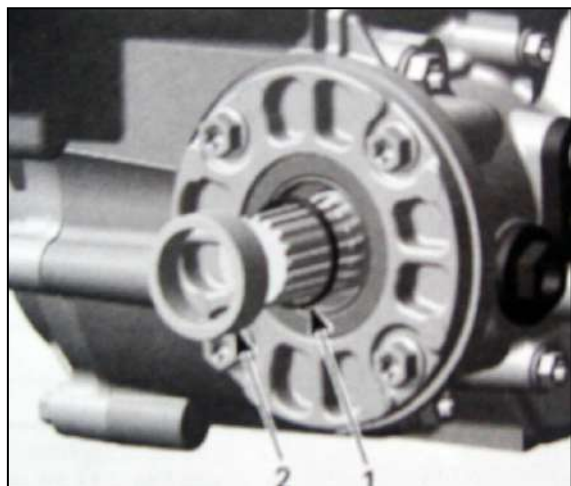

1. O-ring
2. Distance sleeve

NOTE: To install the right housing align the coupling

fork with the groove in the coupling sleeve.

First, torque the four (4) M8 screws in a crisscross sequence by hand then retighten to 25 Nm.

Tighten all M 6 screws to 10 Nm.

Before installing bearing cover, apply Loctite 5910 on the housing and Super Lube grease on seal.

Once this is done, complete final assembly.

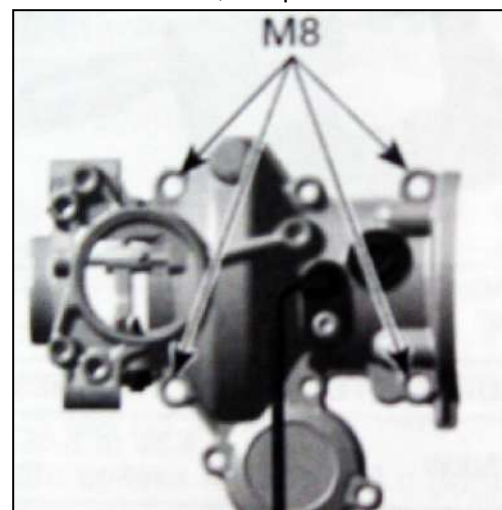

3.28.5 GEARS

Removal

Unscrew the three (3) nuts attach the gearbox to the engine.

Pull gearbox to separate it from engine.

Disassembly

NOTE: During gearbox disassembly, inspect the condition of each part closely.

Remove the output shaft.

Push bevel gear with a pin lightly down and measure the axial clearance of bevel gear with a feeler gauge.

NOTE: Bevel gear axial clearance must be measured before center and left housings separation.

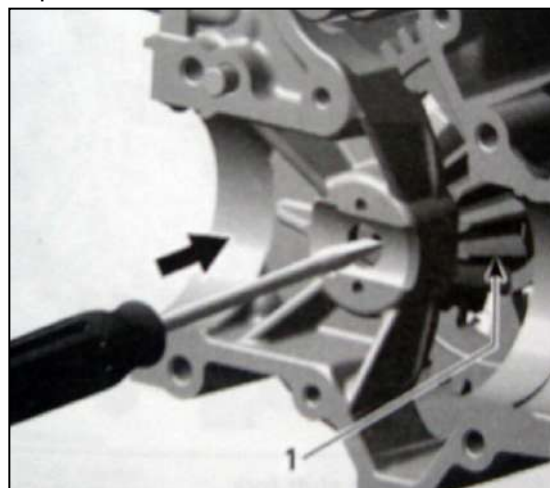

1. Bevel gear

Unscrew the left housing screws.

Place the left housing on a wood stand, center housing pointing upwards.

Using two big flat screwdrivers, lift the center housing.

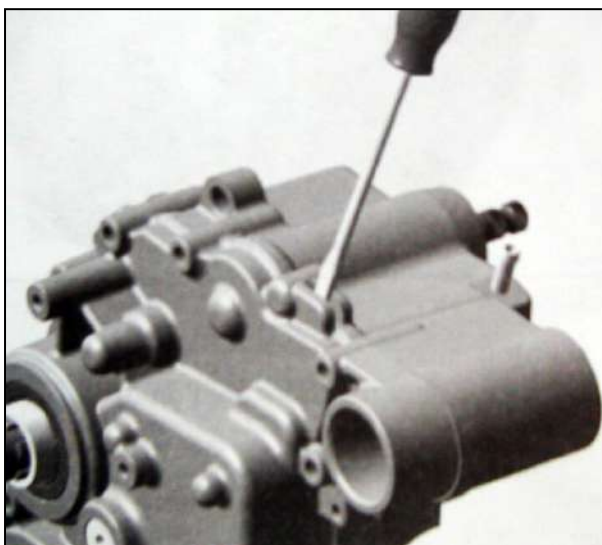
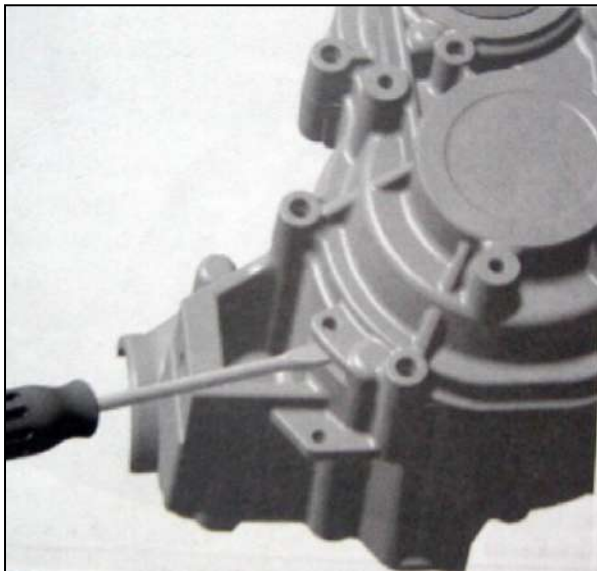

Remove center housing completely.
Remove:
-Shift shaft assembly



1. Shift shaft assembly
-Shift fork shaft
-Disengage shift fork from shift drum

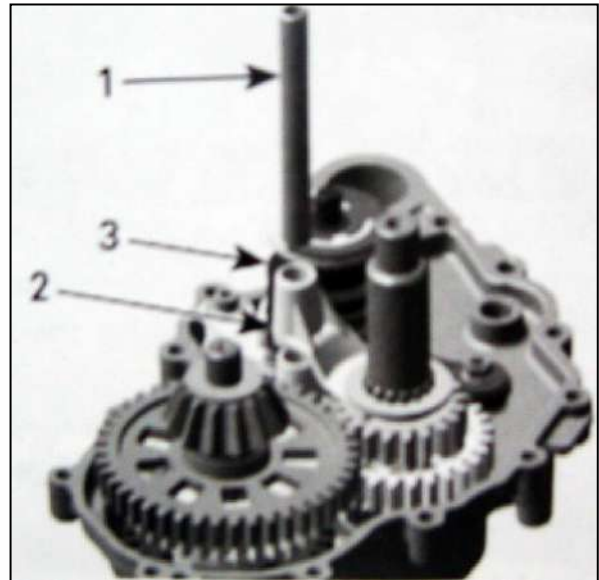

1. Shift fork shaft
2. Shift fork
3. Shift drum
-Bevel gear shaft with low range gear assembly and thrust washer

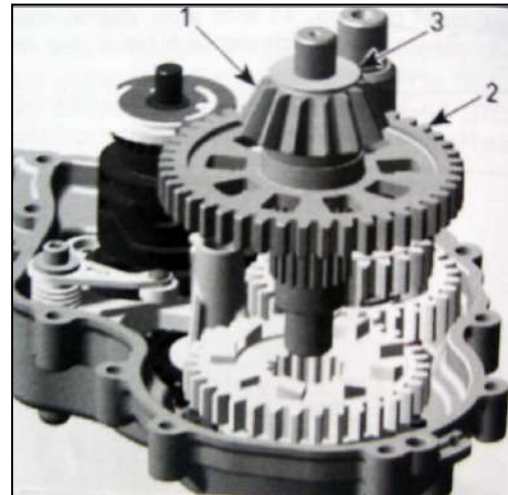

1. Bevel gear
2. Low range gear
3. Thrust washer
-sliding gear with shift fork



1. Sliding gear
2. Shift fork

-thrust washer, needle bearing and reverse gear

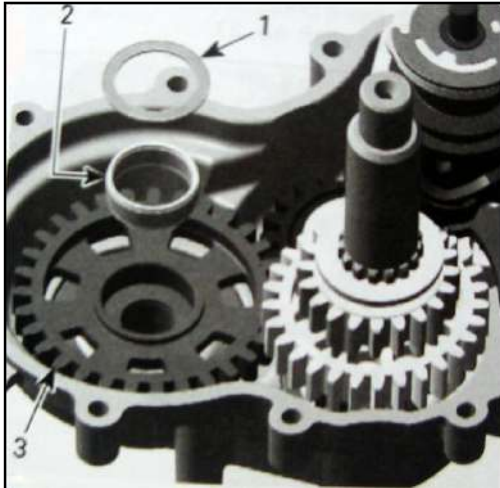

1. Thrust washer
2. Needle bearing
3. Reverse gear

-Thrust washer CVT side



1. Thrust washer CVT side

-Countershaft with low range gear and high range gear assembly.

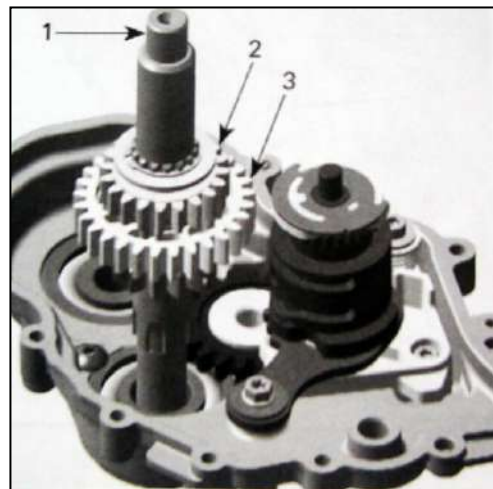

1. Countershaft
2. Low range gear
3. High range gear

Insert a flat screwdriver in the slot of index lever. Turn screwdriver clockwise and remove shift drum.

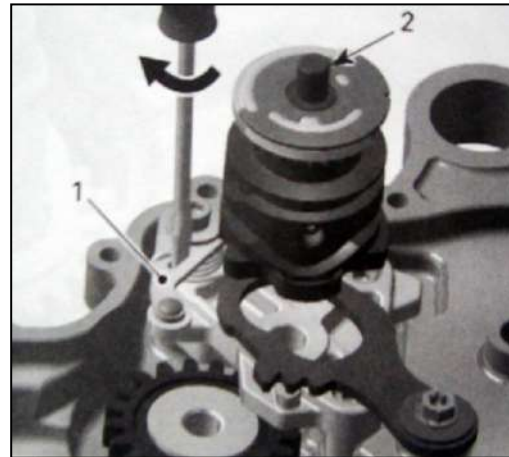

1. Index level
2. Shift drum

Continue by removing the following:

-Parking lock lever

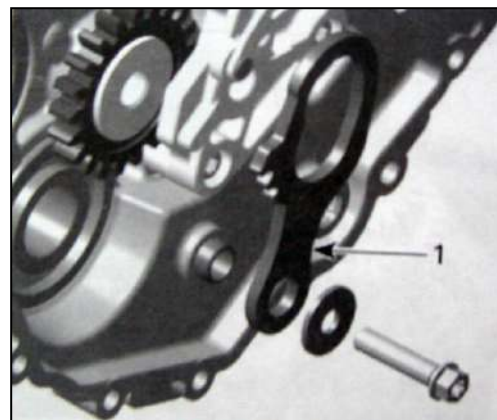

1. Parking lock level
- Index lever with washer, step ring and spring

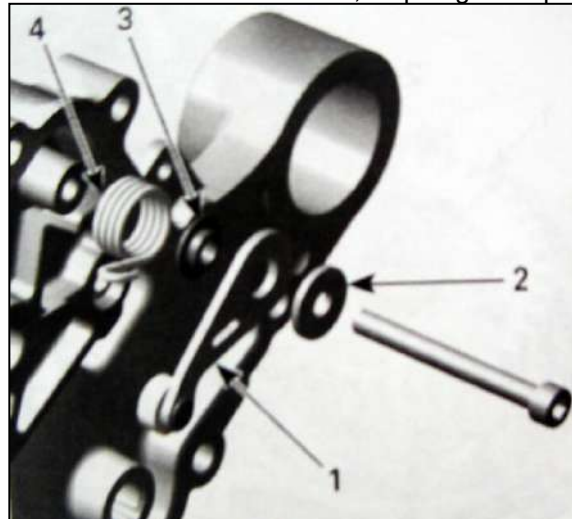

1. Index lever
2. Washer
3. Step ring
4. Index spring

-Support flange.

To remove intermediate gear and needle bearing, use a press bench to push out the intermediate gear shaft.

PRESS SHAFT IN THE DIRECTION AS SHOWN BY THE ARROW



1. Intermediate gear shaft
2. Left housing

Bearing removal in Housing

If necessary, heat housing up to 100°C before removing ball bearings or needle bearings.

CAUTION: Always support gearbox housings properly when ball bearings or needle bearings are removed. Housing damages may occur if this procedure is not performed correctly.

To remove bevel gear needle bearing use a punch.

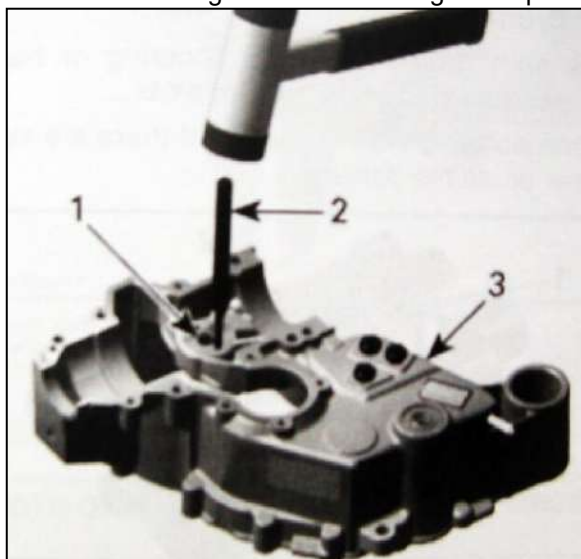

1. Bevel gear needle bearing
2. Punch
3. Center housing

To remove ball bearings of bevel gear and needle bearing of countershaft, use a blind hole bearing puller.



For countershaft ball bearing, remove screw and intermediate gear shaft, then push with a suitable puller from outside in.

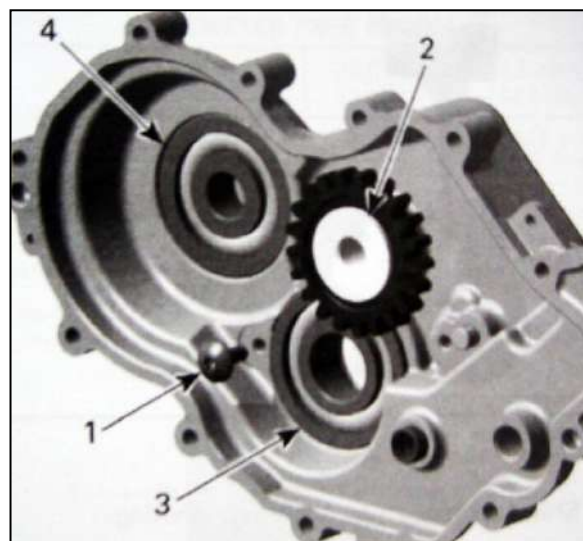

1. Screw
2. Intermediate gear shaft
3. Ball bearing countershaft
4. Bevel gear ball bearing

Inspection

Always verify for the following when inspecting gearbox components:

- Gear teeth damage
- Worn or scoured bearing surfaces
- Worn or scoured shift fork
- Worn or scoured shift fork shaft
- Rounded engagement dogs and slots
- Bent shift forks
- Bent shift fork shaft
- Worn shift fork engagement pins
- Worn tracks on shift drum
- Worn shift fork engagement groove
- Worn splines on shafts and gears.

Bearing

Check if bearings as well as needle bearings turn freely and smoothly.

Check all bearings, bearing points, tooth flanks, taper grooves and annular grooves. Annular grooves must have sharp edges.

Shift Forks

Check both shift forks for visible damage, wear or bent shift fork claws.

Measure the shift fork claw thickness.



1. Micrometer
- A. Shift fork claw thickness

Shift fork claw thickness	
New	4.95 to 5.05 mm
Service limit	4.80mm

Measure shift fork pins.

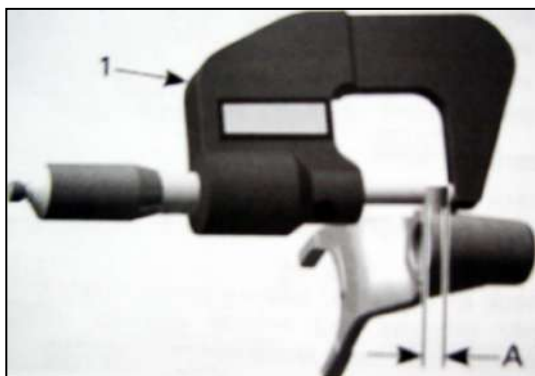

- 1. Micrometer
- A. Shift fork pin diameter

Shift fork pin diameter	
New	6.942 to 7.00 mm
Service limit	6.850 mm

Shift Drum

Check shift drum tracks for scouring or heavy wear, like rounded engagement slots.

Replace isolating washer if there are signs of wear or visible damages.



- 1. Track for the low/reverse gear shift fork
- 2. Track for the high gear shift fork
- 3. Isolating washer on the shift drum

Levers

Check parking lever for cracks or other damages. Index lever with roller must move freely.

Gears

NOTE: Replace gears only together with the corresponding meshing gears. Always replace circlips and use special pliers to install them. Measure the width of shift fork engagement groove.

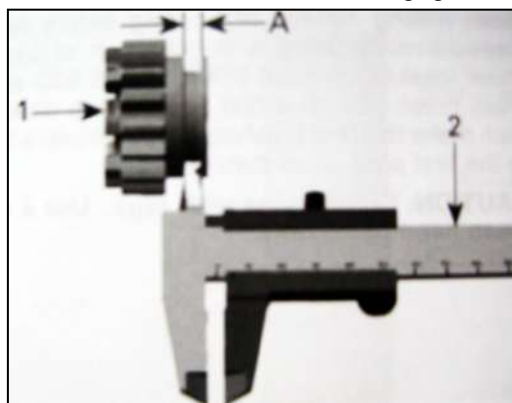

- 1. Main gear
- 2. Caliper
- A. Width for engagement of shift fork

-Gear for high gear shifting.

Width of shift fork engagement groove (high gear shifting)	
New	5.10 to 5.17 mm
Service limit	5.20 mm

-Gear for low/ reverse gear shifting.

Width of shift fork engagement groove (low/reverse gear shifting)	
New	5.10 to 5.17 mm
Service limit	5.20 mm

Check free pinion for wear.

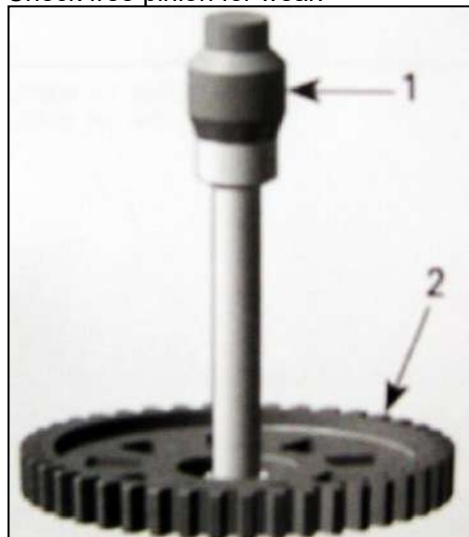

- 1. Micrometer
- 2. Free pinion

Diameter free pinion	
New	29.007 to 29.028 mm
Service limit	29.030 mm

Shafts

Check shaft for worn splines and gears. Check intermediate shaft for wear.

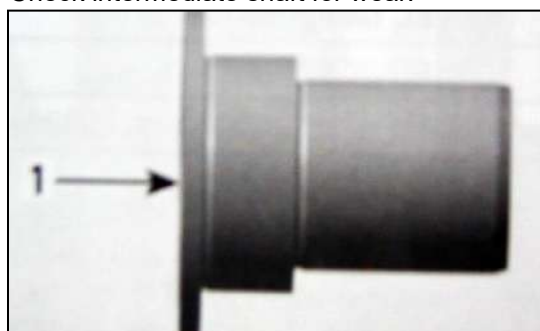

- 1. Intermediate gear bearing

Intermediate gear shaft	
New	24.980 to 24.993 mm
Service limit	24.977 mm

Check countershaft for wear.

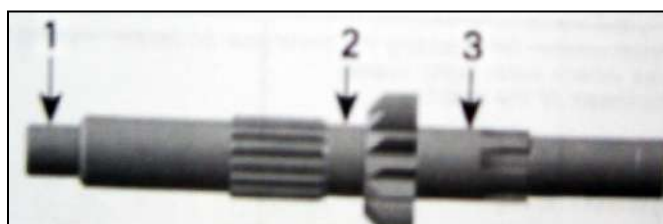

- 1. MAG side
- 2. Free pinion bearing
- 3. CVT side

Countershaft	
Service limit	
MAG side	17.974 mm
Free pinion bearing	24.970 mm
CVT side	24.970

Check bevel gear shaft.



1. free pinion bearings

Bevel gear shaft	
Service limit	
Free pinion bearing	24.972 mm

Shims

Always replace shim by a new one with the same thickness, when reassembling the gearbox with existing output shaft and bevel gear shaft.

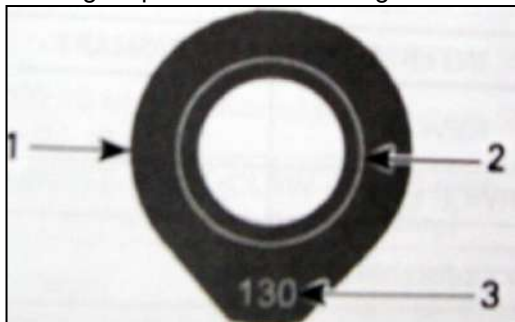

1. Thrust washer for adjusting the bevel gear on center housing side
2. Area where wear signs appear
3. Thickness of the washer

Bevel Gear Adjustment

NOTE: Only necessary if backlash and axial clearance of the bevel gear is out of specification or if parts are changed (output shaft, bevel gear shaft or housing).

There are 2 adjustments to perform on the bevel gear.

- Bevel gear backlash on center housing
- Bevel gear axial clearance on left housing.

The bevel gear backlash is adjusted by finding the proper thrust washer thickness E as per following illustration.

The bevel gear axial clearance is adjusted by finding the proper thrust washer thickness J as per following illustration.

Clean mating surface of housing before taking measurements.

CAUTION: Do not wipe with rags. Use a new clean hand towel only.

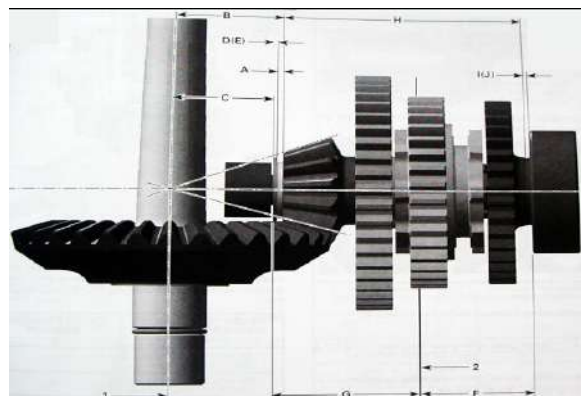

Bevel Gear Back Lash Procedure

Use the following course of calculation to determine the theoretical thrust washer thickness D:

$$D = B - C - A$$

B = the distance between the thrust surface of the bevel gear and the theoretical center of its taper. This is defined by manufacturer and is written on the bevel gear shaft.

This bevel gear reference number could be between -10 and + 10.



1. Bevel gear
2. Bevel gear reference number

Use following formula to find out value B.

$$B = (\text{bevel gear reference number})/100 + 37.8$$

For example: Bevel gear reference number = -3.

$$B = (-3/100) + 37.8 = 37.77$$

C = Distance between the shim thrust surface in the center housing and the mating surface to left housing.

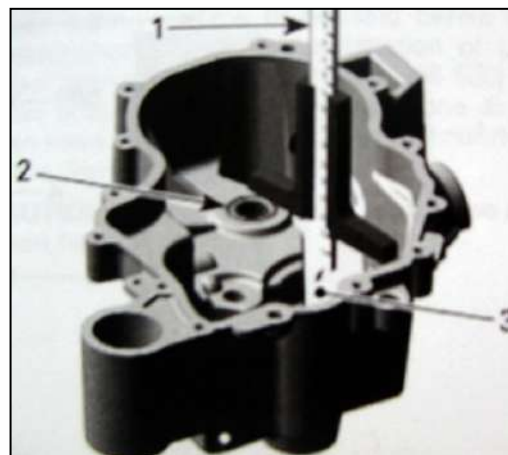

1. Deep gauge – measurement C
2. Thrust washer surface in center housing
3. Mating surface to left housing

A = 2 mm nominal thickness of axial needle bearing.

When the measurements are taken, calculate the theoretical thrust washer thickness D using the formula ($D = B - C - A$)

Take the obtained theoretical thrust washer thickness D and choose the corresponding thrust washer number E according to the following table.

NOTE: For example, if the theoretical thrust washer thickness D is 1.53 mm, choose the corresponding thrust washer number 150 E. the thrust washer number 150 represents a nominal value equal to 1.50 mm.

Theoretical Thrust Washer Thickness D	Thrust Washer Number E
1.20 mm to 1.29 mm	120
1.30 mm to 1.39 mm	130
1.40 mm to 1.49 mm	140
1.50 mm to 1.59 mm	150
1.60 mm to 1.69 mm	160
1.70 mm to 1.79 mm	170
1.80 mm to 1.89 mm	180

Bevel Gear Axial Clearance Procedure

Use the following course of calculation to determine the theoretical thrust washer thickness I:

$$I = F + G - H - A - E$$

F = Distance between mating surface of left housing to ball bearing inner race.

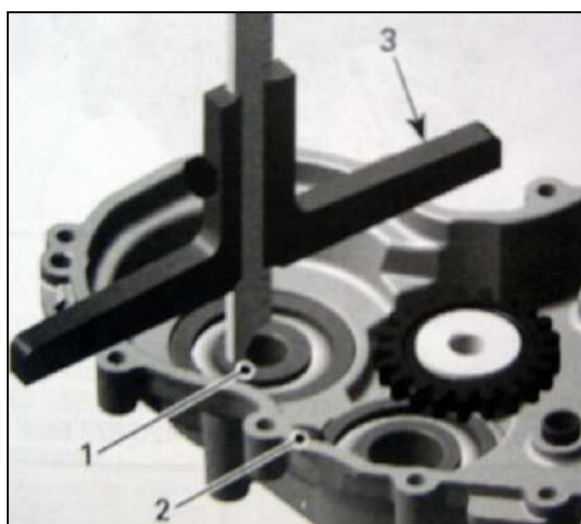

- 1. Ball bearing inner race
- 2. Mating surface of left housing
- 3. Depth gauge

G = Distance between mating surface of center housing and thrust washer surface.

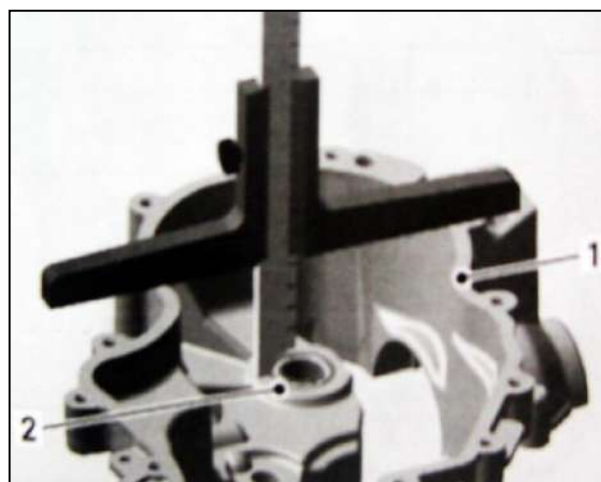

- 1. Mating surface of center gear housing
- 2. Thrust washer surface

H = Distance between thrust surface of bevel gear shaft.

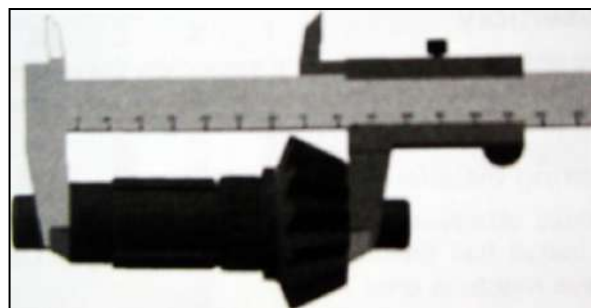

A = 2mm nominal thickness of axial needle bearing.
E = the thrust washer number nominal value as found in the BEVEL GEAR BACKLASH PROCEDURE. For example, thrust washer number 150 represents a value of 1.50 mm.

When the measurements are taken, calculate the theoretical thrust washer thickness I using the formula ($I = F + G - H - A - E$)

Take the obtained theoretical thrust washer thickness I and choose the corresponding thrust washer number J according to the following table.

For example, if the theoretical thrust washer thickness I is 1.53 mm, choose the corresponding shim number 150 J.

Bevel gear axial clearance of 0.02 to 0.11 mm is included in the table.

THEORETICAL THRUST WASHER THICKNESS I	THRUST WASHER NUMBER J
1.22 mm to 1.31 mm	120
1.32 mm to 1.41 mm	130
1.42 mm to 1.51 mm	140
1.52 mm to 1.61 mm	150
1.62 mm to 1.71 mm	160
1.72 mm to 1.81 mm	170
1.82 mm to 1.91 mm	180

Assembly

The assembly of gearbox is essentially the reverse of disassembly procedure. However, pay attention to the following details.

Bearing Installation in Housing

Unless otherwise instructed, never use hammer to install ball bearings or needle bearings. Use press machine only.

If necessary, heat housings up to 100°C before installing ball bearings or needle bearings.

Place new bearing in freezer for 10 minutes before installation.

Use a suitable installer for installing ball bearings of countershaft and bevel gear.

NOTE: Place gearbox housings on a wood stand before installing bearings.

Install countershaft needle bearing with the main shaft needle bearing installer and the installer handle in right housing.



- 1. Needle bearing installer
- 2. Installer handle

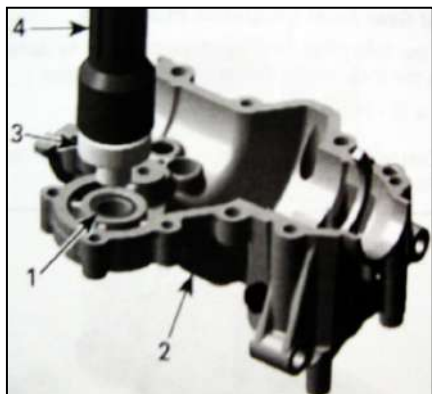

- 1. Countershaft needle bearing
- 2. Right housing
- 3. Needle bearing installer
- 4. Installer handle

Install bevel gear needle bearing using the bevel gear needle bearing installer and the installer handle.

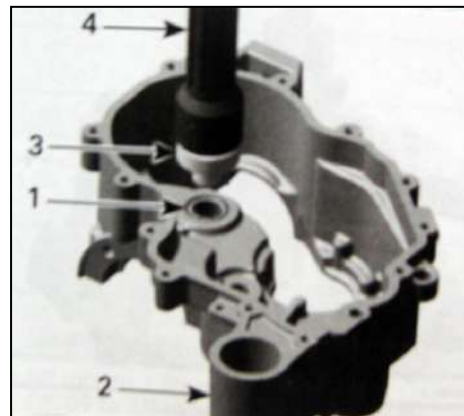

- 1. Bevel gear needle bearing
- 2. Center housing
- 3. Needle bearing installer
- 4. Installer handle

Install new oil seals with the proper installer.

Other Gearbox Components

Fit intermediate gear with needle bearing on intermediate gear shaft.

NOTE: Fit gear with collar face to housing side on the intermediate shaft.

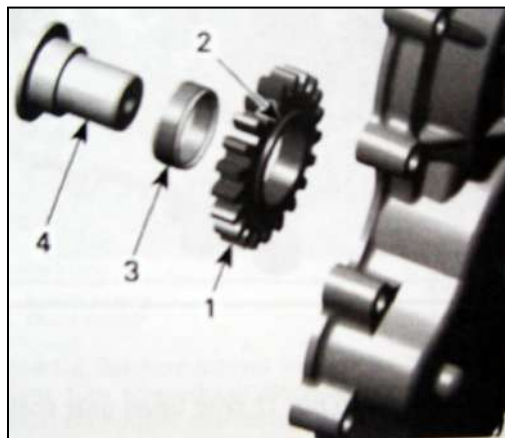

- 1. Intermediate gear
- 2. Collar facing housing
- 3. Needle bearing
- 4. Intermediate gear shaft

Press intermediate gear shaft in the left housing.

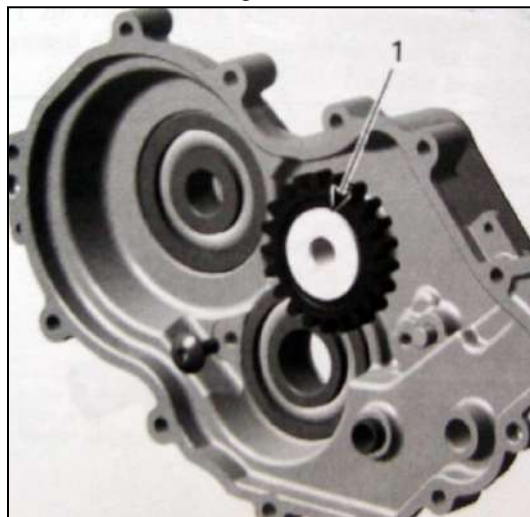

- 1. Intermediate gear shaft

Fit support flange in the left housing and install index lever.

NOTE: Fit step ring into index lever.

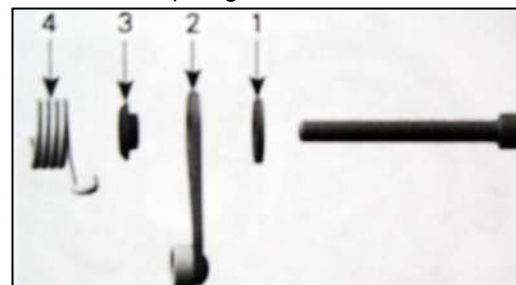

- 1. Shim
- 2. Index lever
- 3. Step ring
- 4. Index spring

Install parking lock level, teeth showing to countershaft.

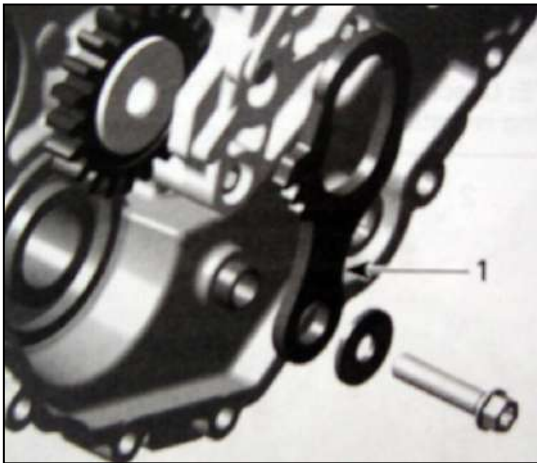

1. *Parking lock lever*
Place thrust washer CVT side on bearing.

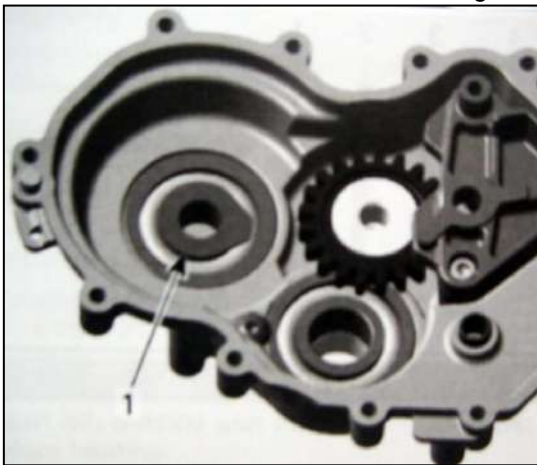

1. *Thrust washer CVT side*
Place reverse gear with needle bearing and thrust washer.
NOTE: Check if the screw to secure countershaft bearing is installed.

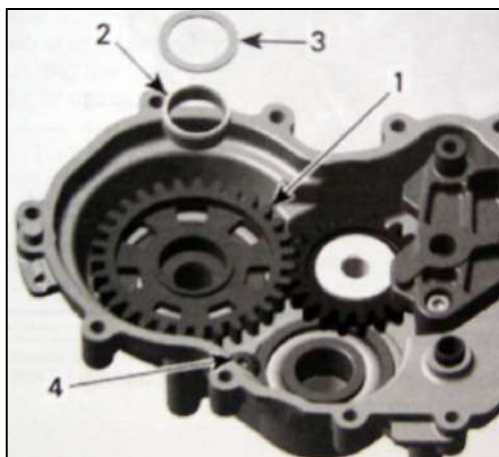

1. *Reverse gear*
2. *Needle bearing*
3. *Thrust washer*
4. *Countershaft bearing screw*
Install countershaft with low gear and high gear assembly.

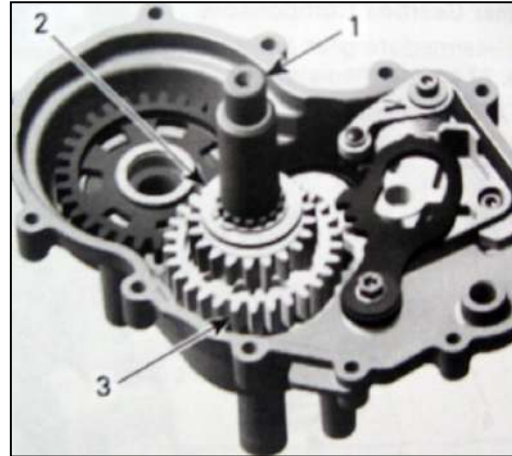

1. *Countershaft*
2. *Low gear*
3. *High gear*

Install a new shim onto bevel gear shaft, fork side. Install bevel gear with sliding gear assembly together with shift fork.

NOTE: If a new bevel gear and output shaft are used, it is necessary to verify the shim adjustment prior to finalize assembly. Refer to ADJUSTMENT above in this section. If the existing bevel gear is used, it is mandatory to use a new shim with the same thickness, a new needle bearing and thrust washer.



1. *Bevel gear*
2. *Sliding gear*
3. *Shift fork*

Install a new needle bearing and thrust washer.

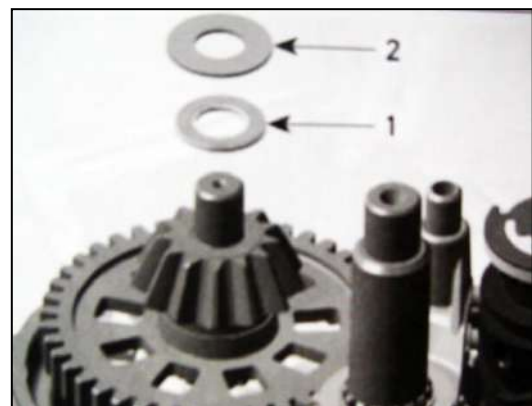

1. *Needle bearing*
2. *Thrust washer*

Insert a flat screwdriver in the slot of the index lever, turn screwdriver clockwise and install shift drum on neutral position as per following illustration.



1. Index lever
2. Shift drum
3. Neutral position

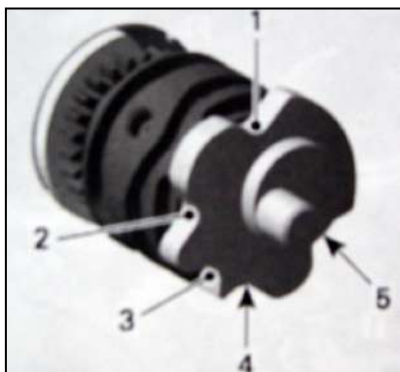

1. Parking stop location
2. Reverse stop location
3. Neutral stop location
4. High gear stop location
5. Low gear stop location

Install shift shaft assembly.

NOTE: Marks on shift drum/isolating washer and shift shaft must align.



1. Shift shaft assembly
2. Isolating washer
3. Marks

Install shift fork then engage both shift fork pins in their corresponding groove on the shift drum.

NOTE: move sliding gears to facilitate engagement of pins inside grooves.



1. Shift fork pin
2. Sliding gear

Install shift fork.

NOTE: Run all gears as a final function check before installing center housing.

Now, close the housings by doing the following:

Clean all metal components in a solvent.

Gearbox housing mating surfaces are best cleaned.

CAUTION: Do not wipe with rags. Use a new clean hand towel only.

IMPORTANT: When beginning the application of the gear housing sealant, the assembly and the first torquing should be done within 10 minutes. It is suggested to have all you need on hand to save time.

Use Loctite 5910 on mating surfaces.

Use a plexiglass plate and apply some sealant on it. Use a soft rubber (50-75 mm), available in arts products suppliers for printing, and roll the sealant to get a thin uniform coat on the plate (spread as necessary). When ready, apply the sealant on gear housing mating surfaces.

Do not apply in excess as it will spread out inside gear housing.

NOTE: It is recommended to apply this specification without lumps. If you do not use the roller method, you may use your finger to uniformly distribute the sealant (using a finger will not affect the adhesion). Hand-torqued gear housing screws in a crisscross sequence. Repeat procedure, retightening all screws to 10 Nm.

Install O-ring including distance sleeve on countershaft CVT side.

CAUTION: Place O-ring including distance sleeve right away. Chamfered bore of distance sleeve has to face the gearbox.

Installation

The installation is the reverse of the removal procedure.

Filling Procedure

Make sure that magnetic drain plug is reinstalled and tight.

With the gearbox on a level surface, fill the gearbox through the oil filler hole with GL-4-90 or with an equivalent product until the oil reaches the lower threads of the oil filler hole (about 420 ml).

3.29 ENGINE INSTALLATION

The engine installation is the reverse of the removal procedure. However, pay attention to the following.

1. Prior to install engine, inspect condition of engine mounts. If necessary, replace the engine mounts, you can insert a punch in hole of engine mount bushing and push the other bushing out of the housing.

2. Make sure coolant and oil drain plugs are reinstalled and tight.

Refill engine oil and check the oil level with the dipstick.

4. COOLING SYSTEM

GENERAL.....	4-1	TROUBLESHOOTING.....	4-2
MAINTENANCE.....	4-2	INSPECTION.....	4-3
PROCEDURE.....	4-3		

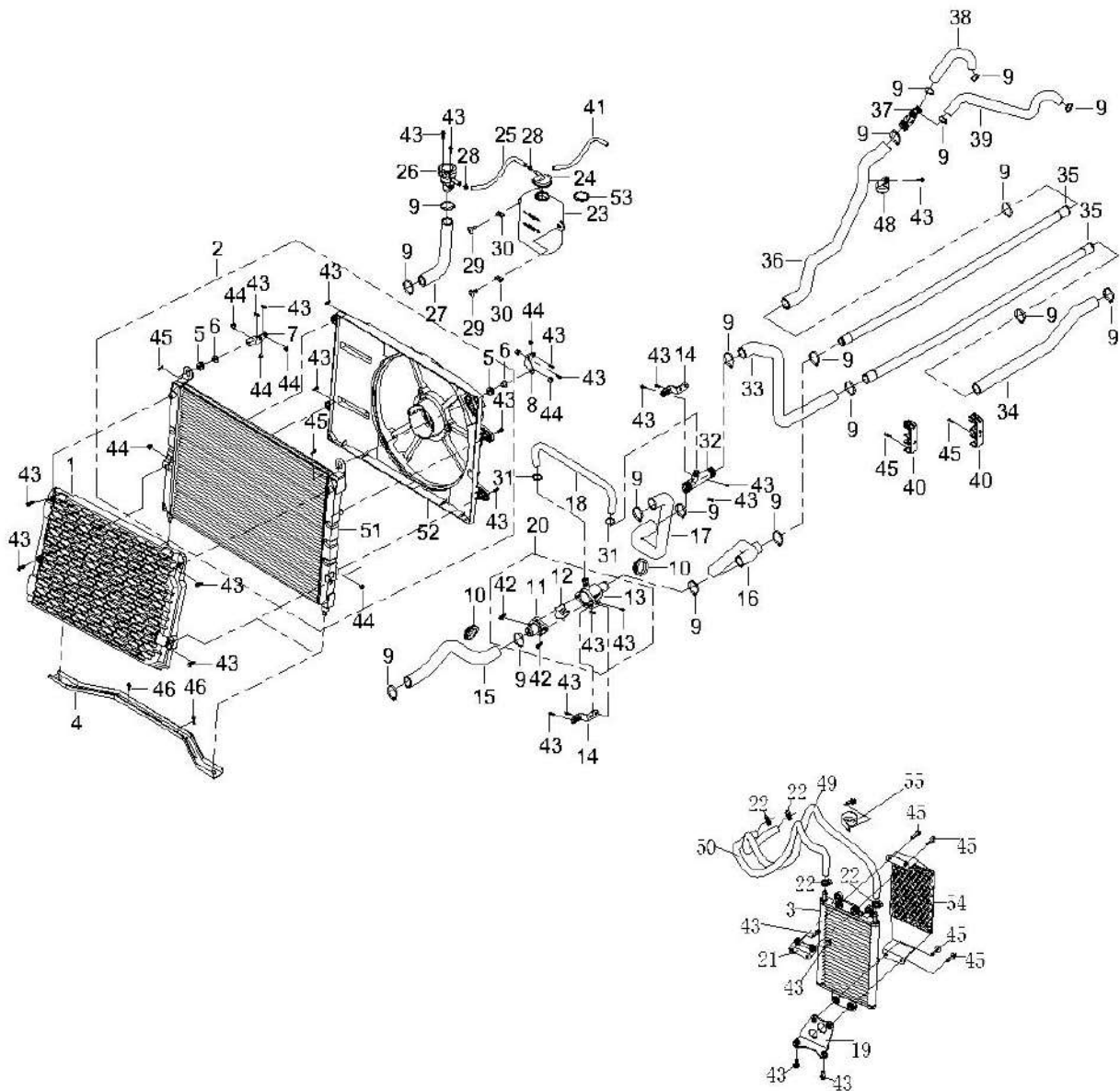

4.1 GENERAL

⚠WARNING
 Never start engine without coolant. Some engine parts such as the rotary seal on water pump shaft can be damaged.

Clean thread before applying a thread locker.

⚠WARNING
 Torque wrench tightening specifications must be strictly adhered to.
 Locking devices must be replaced with new ones when removed (e. g.: locking tabs, elastic stop nuts, self-locking fasteners, cotter pins, etc.).

1. If cover of radiator is open and temperature of cooling liquid is over 100°C, pressure of cooling liquid will be reduced rapidly and boiled. Vapor injection may cause danger and injuries. After drop

of temperature of cooling liquid, use one cloth to cover the cover of radiator and then slowly open the cover. Cooling liquid can only be tested after complete cooling.

2. Cooling liquid is toxic. Do not drink it or splash it to skin, eyes or clothes. In case of splashing cooling liquid to your eyes, use clean water to wash your eyes completely and contact the doctor. In case of splashing cooling liquid to your clothes, use soapy water to wash it rapidly. In case of drinking cooling liquid, vomit will be caused immediately. Please see the internist physician immediately. Store cooling liquid well and keep it out of reach of children.

3. Check whether soil of fins is blocked or damaged. Correct curved fins. Use water and compressed air to clean soil. If damaged area reaches 20%, please replace radiator.

4. Pump overhauling can be carried out before dismantling engine.

5. Add cooling liquid to water tank. In addition to adding or exhausting cooling liquid, please do not open cover of radiator.
6. Do not splash cooling liquid to plastic parts. Once splashed, please use clean water for washing.
7. After dismantling cooling system, check leakage situation of joint.

4.2 TROUBLESHOOTING

Sharp rise of water temperature

- Faults of radiator cover
- There is air in cooling system.
- Faults of water pump
- Faults of thermostat (thermostat is not open)
- Blockage of radiator tube or cooling tube
- Damage or blockage to radiator
- Incomplete cooling liquid
- Failure or faults of fan motor

No rise or slow rise of water temperature.

- Faults of thermostat (thermostat is not closed)
- Faults of line of water temperature display

Leakage of cooling liquid.

- Faults of water seal
- Aging, damage or improper sealing to O-ring.
- Aging, damage or improper sealing to gasket
- Improper installation of pipe or hose
- Aging, damage or improper sealing to pipe and/or hose

▲ WARNING

Never start engine without coolant. Some engine parts such as the rotary seal on water pump shaft can be damaged.

4.3 MAINTENANCE

COOLANT REPLACEMENT

▲ WARNING

To avoid potential burns, do not remove the radiator cap or loosen coolant drain plug if the engine is hot.

Recommended Engine Coolant

Recommended Engine Coolant

Distilled water and antifreeze solution (50% distilled water, 50% antifreeze).

To prevent antifreeze deterioration, always use the same brand. Never mix different brands unless cooling system is completely flushed and refilled.

CAUTION: To prevent rust formation or freezing condition, always replenish the system with the premixed coolant or with 50% antifreeze and 50% water. Do not use tap water, straight antifreeze or straight water in the system. Tap water contains minerals and impurities which build up in the system. During cold weather, straight water causes the system to freeze while straight antifreeze thickens and does not have the same efficiency. Always use ethylene glycol antifreeze containing corrosion inhibitors specifically recommended for aluminum engines.

Drain the Coolant:

NOTE: Never remove the radiator cap immediately when the engine is hot. Wait for the engine to cool sufficiently before removing the radiator cap. Hot coolant can cause serious burns.

1. Place the vehicle on a level surface.
2. Remove front center panel.

3. Remove the radiator cap and the coolant reservoir cap.
4. Place a container under the water pump drain bolt.
5. Remove the water pump drain bolt and washer.

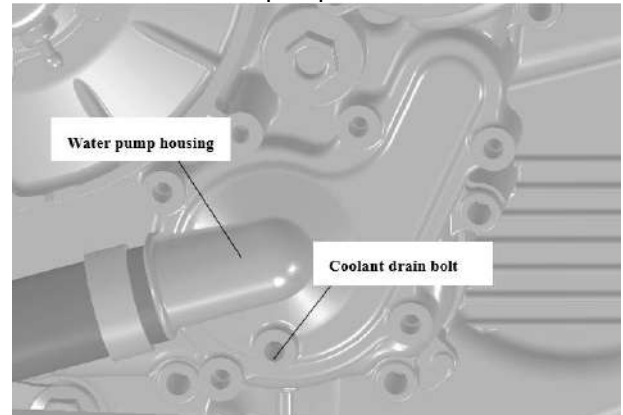

6. Drain out the coolant.
7. Disconnect the hose on the coolant reservoir side, and drain the residual coolant.
8. Flush the cooling system with clean water. Allow the water to drain completely from the system.

Coolant Replacement

1. Inspect water pump drain bolt and washer for damage. Replace new one if damaged.
2. Reinstall drain bolt, but do not tighten completely at this time.
3. Reinstall hose to the reservoir tank.
4. Add recommended coolant to the radiator until it appears at the top.
5. Loosen the water pump drain bolt and drain coolant until there are no air bubbles in the discharge.
6. Tighten drain bolt to 9~12Nm.
7. Refill coolant until the coolant flow out.
8. Install radiator cover.
9. Start the engine and allow it to idle until the cooling fan turns on, then turn off the engine. After cooling completely, check the coolant level in the radiator and adjust it to the top of radiator. Repeat this step until the coolant level does not change.
10. Add coolant on the reservoir tank to the upper mark.
11. Install reservoir tank cap.
12. Inspect cooling system for leaks. Please contact and authorized dealer if a leak is found.
13. Install engine side cover and radiator service cover.

NOTE: Each year or every 100 hours or when vehicle reaches 3000km, check coolant with proper tester.

4.4 INSPECTION

COOLING SYSTEM TEST

▲ WARNING

To avoid potential burns, do not remove the radiator cap or loosen the cooling drain plug if the engine is hot.

Remove the front panel and the radiator cap. Install the test cap and a small hose pincher on overflow hose. Using pressure/vacuum pump, pressurize system to 100 kPa.

Check all hoses, radiator and cylinder/base for coolant leaks or air bubbles.

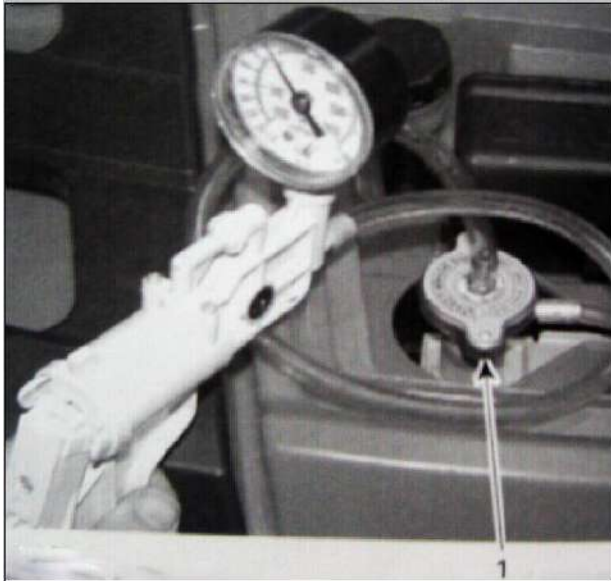

Inspection

Check general condition of hoses and clamps tightness. Check the leak indication hole if there is oil or coolant.

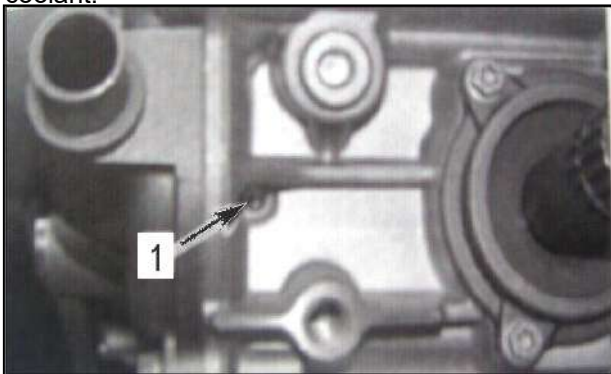

1. Leak indicator hole

NOTE: Flowing coolant indicates a defective rotary seal. Oil indicates a defective inner oil seal. If either seal is leaking, both seals must be replaced at same time. Refer to *WATER PUMP SHAFT AND SEAL* in this section.

Another leak indicator hole is visible on the PTO side. It indicates if the PTO gasket is in good condition. If a liquid leaks by this hole, the PTO gasket replacement is necessary.



**4.5 PROCEDURE
THERMOSTAT**

The thermostat is a single action type. The thermostat is located on the top of cylinder head, on intake side.

Remove:

- thermostat housing screws and pull thermostat cover.
- thermostat with gasket out of the hole.

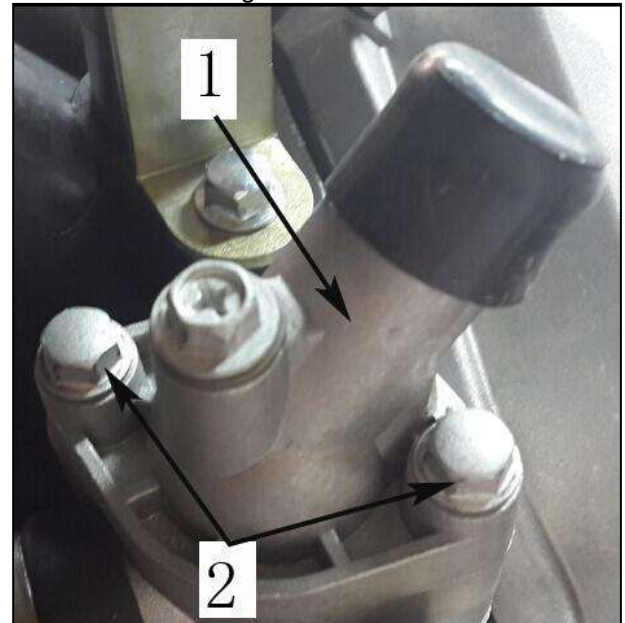

TYPICAL

- 1. Thermostat cover
- 2. Screws

Thermostat Test

To check thermostat, put in water and heat water. Thermostat should open when water temperature reaches 65°C(149°F).

Check if the gasket is brittle, hard or damaged. If damaged, replace gasket.

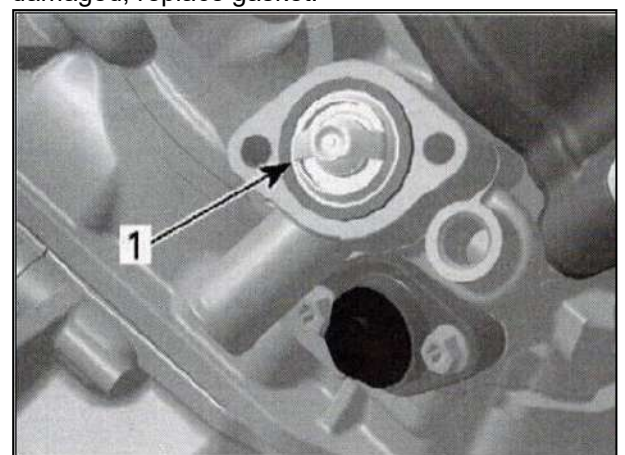

Thermostat Installation

For installation, reverse the removal procedure, pay attention to the following details.

Install the thermostat cover then torque screws to 6N.m.

Check coolant level in radiator and coolant tank and top up if necessary.

Do not forget to bleed the cooling system. Refer to

COOLANT REPLACEMENT.

RADIATOR AND CAP

Using a pressure cap tester, check the efficiency of radiator cap. If the efficiency is feeble, install a new 100 kPa cap (do not exceed this pressure).

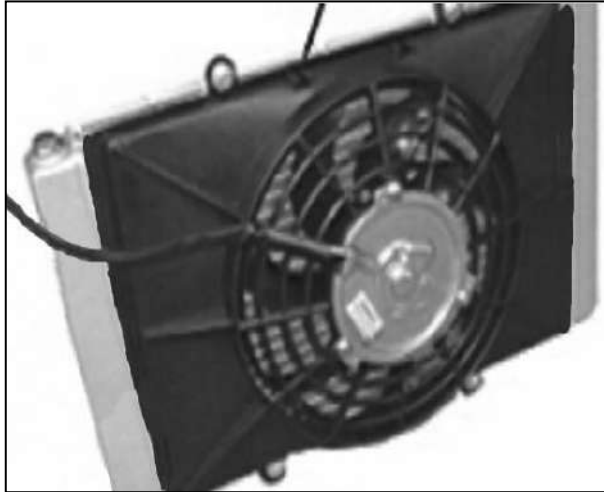

Radiator Inspection

Check radiator fins for clogging or damage. Remove insects, mud or other obstructions with compressed air or low-pressure water.

Radiator Removal

Drain cooling system. Remove front bumper and front headlight cover. Remove front panel and liner.

Remove:

- Radiator inlet and outlet hoses
- Overflow hose.
- Coolant tank support bolt.
- Remove radiator.

Radiator Installation

For installation, reverse the removal procedure. Pay attention to the following detail. Fill up the radiator. Refer to *COOLANT REPLACEMENT*, in this section. Check for any coolant leakage from radiator and hoses.

Tighten the M6 bolts for retaining radiator to 9-12N.m.

COOLANT TANK

The coolant expands as the temperature (up to 100-110°C) and pressure rise in the system. If the limiting system working pressure cap is reached 110kPa, the pressure relief valve in the pressure cap is lifted from its seat and allows coolant to flow through the overflow hose into the overflow coolant tank.

Tank Removal

Remove:

- The front bumper and front headlight cover.
- The front panel and liner.
- Coolant tank support bolt.
- Overflow hose and clamp.

Tank Installation

The installation is the reverse of the removal procedure.

RADIATOR FAN

Radiator Fan Removal

Remove bolts. Separate the radiator and fan.

Radiator Fan Test

NOTE: The ECU controls the radiator fan by the input of the coolant temperature sensor (CTS). The radiator fan should turn on when coolant temperature reaches 98°C and should turn off when the coolant cools down at 95°C(203°F).

Connect the vehicle to Diagnostic Tool. Refer to ENGINE MANAGEMENT for procedure and connector location.

In ACTIVATION folder, press COOLANT FAN button.

If fan turns, check CTS, wiring harness and connectors. If all parts are good, replace the ECU. If fan does not turn when COOLANT FAN button is pressed, use the following troubleshooting chart to resolve the problem.

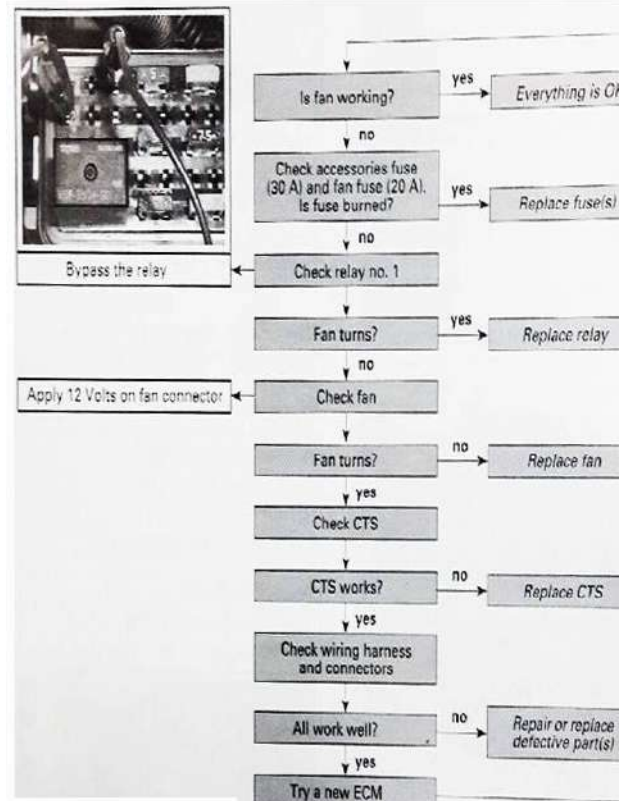

Radiator Fan Installation

For the installation, reverse the removal procedure.

WATER PUMP COVER

It is located on the engine MAG side.

Water Pump Cover Removal

▲ WARNING

To avoid potential burns, do not remove the radiator cap or loosen the cooling drain plug if the engine is hot.

Tilt cargo box.

Drain cooling system.

Remove radiator outlet hose from water pump cover.

Remove bolts retaining water pump cover.

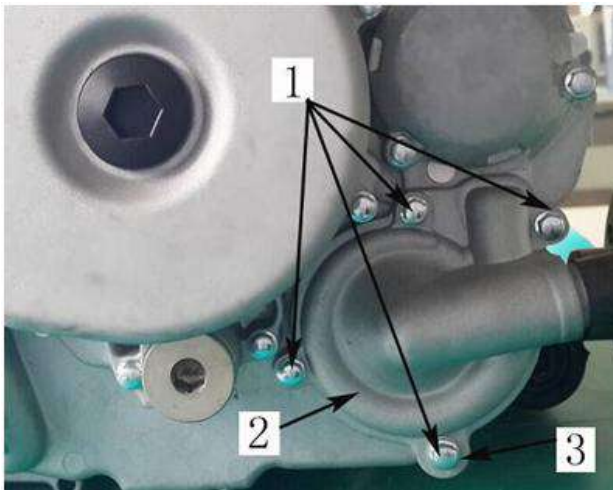

TYPICAL

- 1. Screws
- 2. Water pump cover
- 3. Sealing ring

Pull water pump cover to remove it.

Water Pump Cover Inspection

Check if gasket is brittle, hard or damage and replace as necessary.

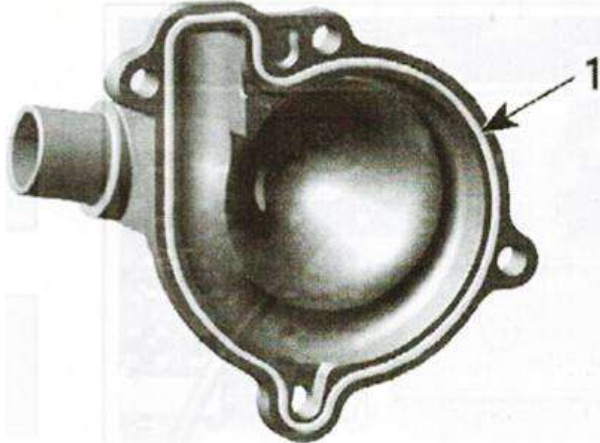

- 1. Gasket

Water Pump Cover installation

The installation is the opposite of the removal procedure.

CAUTION: To prevent leaking, take care that the sealing ring is exactly in groove when you reinstall the water pump cover.

Tighten M6 bolts for water pump cover in the crisscross sequence to 10-12N.m.

Removal

Remove water pump cover.

Unscrew impeller.

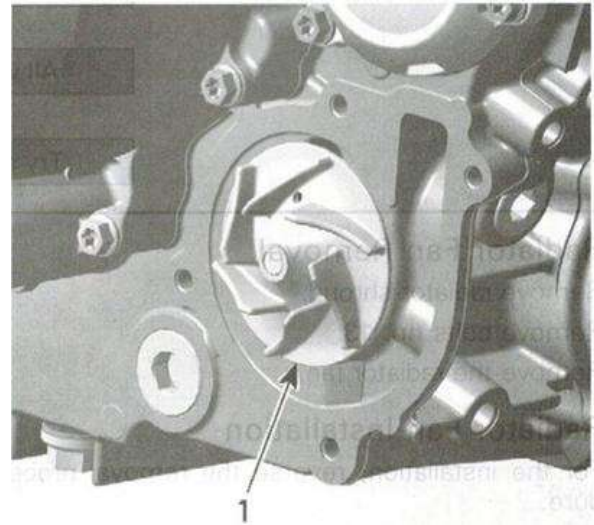

- 1. Water pump impeller

CAUTION: Water pump shaft and impeller have right-hand threads. Remove by turning counterclockwise and install by turning clockwise.

Inspection

Check water pump impeller and shaft for cracks or damage. Replace impeller if damaged.

Impeller Installation

The installation is the opposite of the removal procedure. Be careful not damage impeller wings during installation.

WATER PUMP SHAFT AND SEALS

Shaft/Seal Removal

NOTE: It is not required to split crankcase to replace the water pump shaft and seals, but engine removal is necessary.

Drain engine oil.

Remove engine from vehicle. Refer to ENGINE REMOVAL AND INSTALLATION section.

Detach gearbox from engine.

Remove engine drive shaft and engine PTO cover.

Remove water pump housing and impeller. See procedures in this section.

Pull out water pump gear to disengage the inner drive gear.

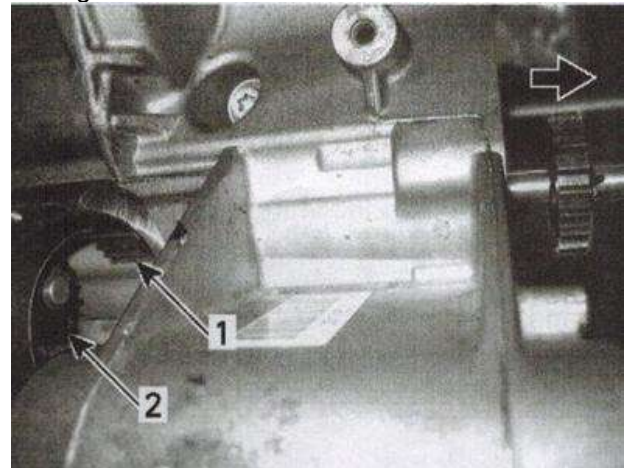

- 1. Water pump gear
- 2. Inner drive gear

Sharply strike water pump shaft out with a plastic

WATER PUMP IMPELLER

hammer.



Pull out water pump shaft through the engine drive shaft opening.

NOTE: Pay attention to hold thrust washer to prevent it from falling in crankcase.

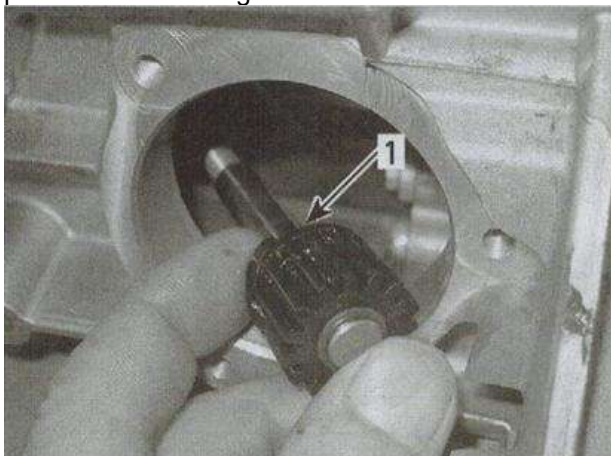

1. Thrust washer here

CAUTION: If thrust washer is not on water pump shaft, use a magnet to retrieve it inside crankcase. Using appropriate pliers remove and discard the retaining ring securing water pump gear on water pump shaft.

To remove plastic gear from water pump shaft place gear between your fingers and briskly tap shaft end.

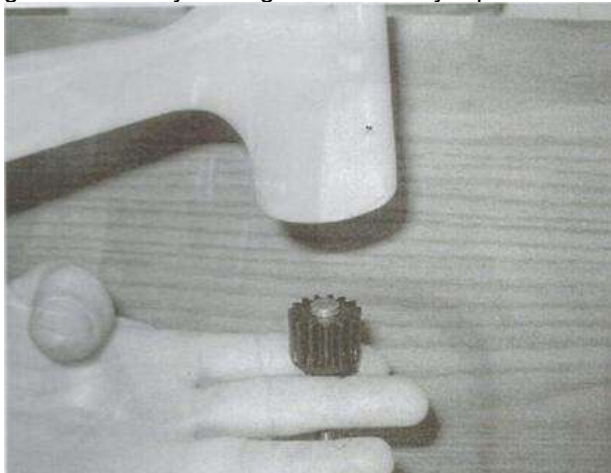

Using 2 screwdrivers, pry out inner part of the rotary seal.



To remove outer part of rotary seal, use an expander from puller kit. Install expander snugly against outer part and pull rotary seal out.

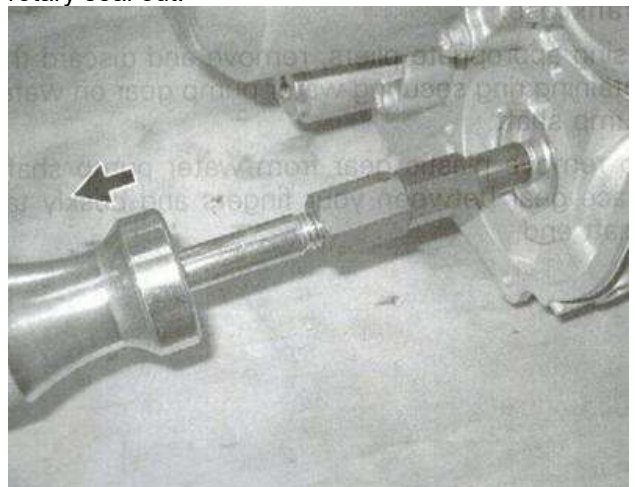

Remove inner oil seal.

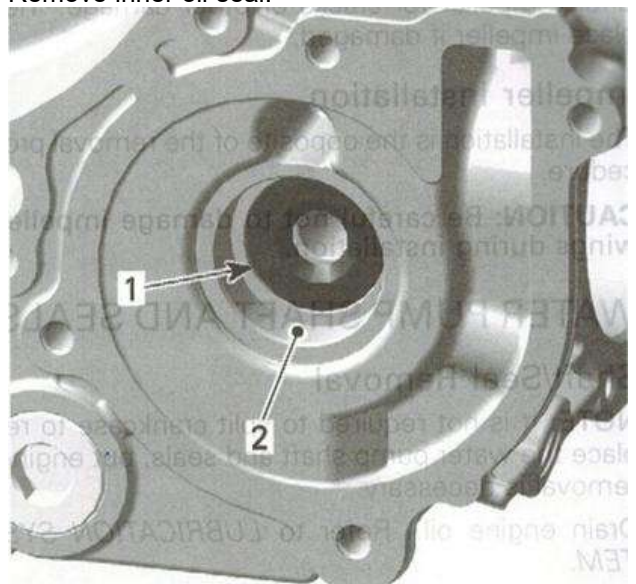

1. Inner seal

2. Rotary seal surface

CAUTION: Be careful not to damage the rotary seal surface in crankcase.

Part Inspection

Inspect water pump gear for wear and damage on the snap mechanism to the needle pin. Replace if damaged.

Shaft/Seal Installation

For installation, reverse the removal procedure.

However, pay attention to the following.

NOTE: For installation use the torque values.

Ensure to use multipurpose grease oil seal.

CAUTION: Always replace rotary seal and water pump shaft together. Also, install a new inner oil seal (behind rotary seal) at the same time.

Apply engine oil on the water pump shaft and intermediate shaft.

NOTE: Never use oil in the press fit area of the oil seal and rotary seal.

Use the oil seal pusher and the installer

Handle to install inner oil seal.

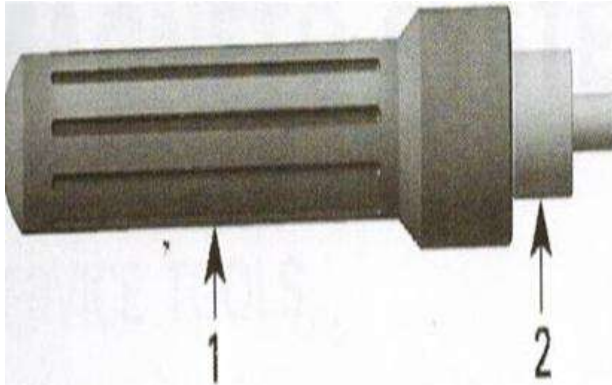

1. Handle
2. Pusher

Apply MOLYKOTE inside lips oil seal when installing the oil seal on the pusher, make sure sealing lip points outside.

Push inner oil seal in place.

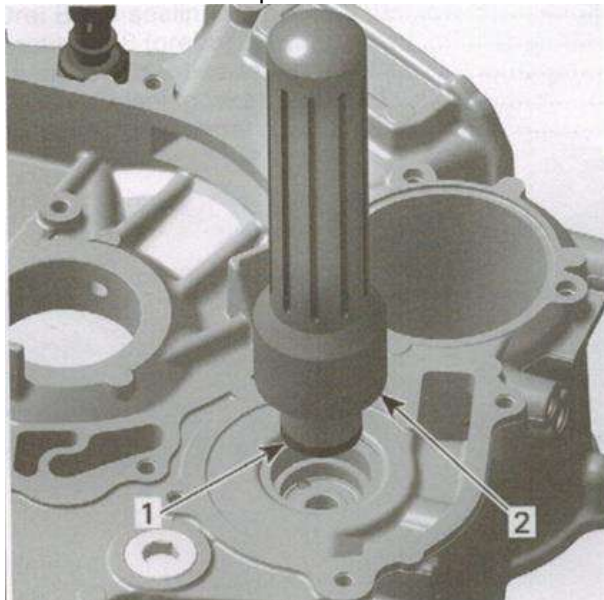

1. Inner oil seal
2. Installer handle with oil seal pusher

Slide water pump shaft with the new rotary seal into crankcase.

To properly install water pump shaft with rotary seal, use the rotary seal installer.

Use a plastic hammer and drive rotary seal into crankcase.

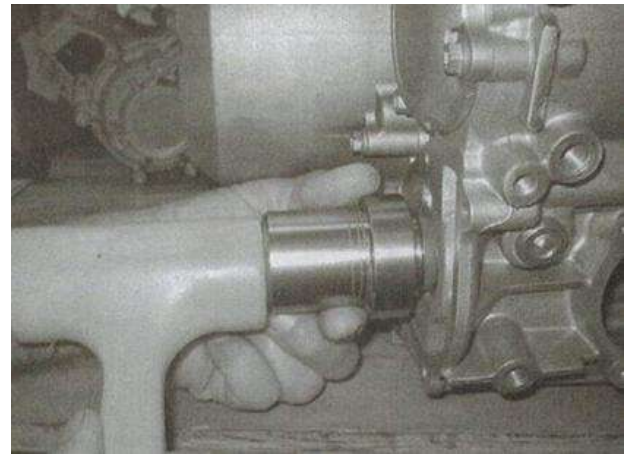

From engine drive shaft opening. Insert thrust washer pump shaft in crankcase.

Using a flashlight and a mirror, position the shaft hole so that pin can be installed.

Position pin between your fingers, push in water pump shaft to fully expose hole then install pin.

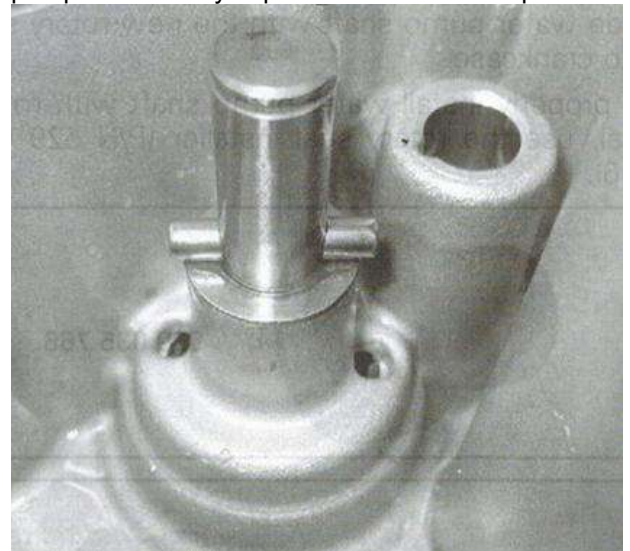

Position pin equal distance out of shaft hole so gear can be installed.

Install water pump shaft gear.

NOTE: Ensure gear properly snaps on pin.

A screwdriver may have to be used to push gear in place.

Use a 45° snap-ring pliers and install a NEW retaining ring on pump shaft end.

CAUTION: Never use the retaining ring a second time. Always install a new one.

After installation, water pump shaft with rotary seal must rotate freely.

Carefully push in water pump gear while turning to mesh with the inner drive gear.

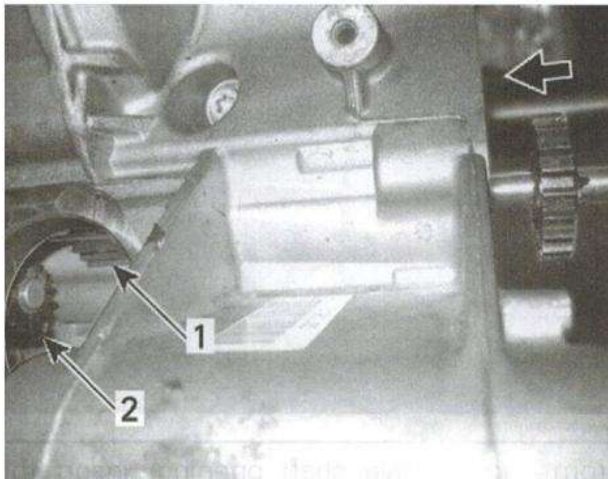

1. Water pump gear
2. Inner drive gear

Tighten screws of the water pump housing crosswise.

Refill all fluids.

COOLANT TEMPERATURE SENSOR(CTS)

Removal

NOTE: The CTS is located on the top of cylinder head near the thermostat.

Install a larger hose pincher on both radiator hoses. Unplug the CTS then remove it.

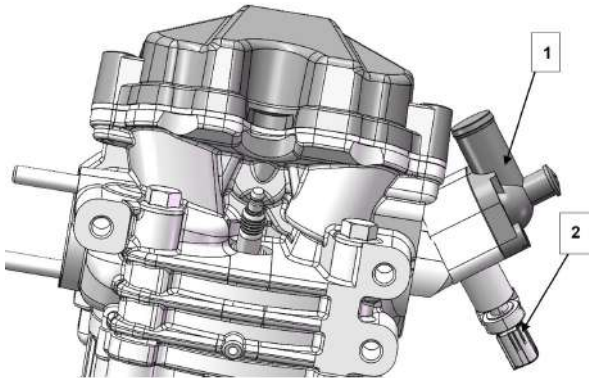

TYPICAL
1. Thermostat
2. CTS

Testing the CTS Resistance

These tests must be performed at room temperature (20 °C (68 °F)).

1. Disconnect the plug connector from the CTS and check the resistance of the sensor itself.

CTS Resistance Test		
CTS pin		Specification
1	2	2280-2740Ω

2. If resistance is out of specification, replace the CTS.
3. If resistance test is good, reconnect the CTS.
4. Disconnect the engine connector from the ECU.
6. Using a multimeter, recheck resistance from the ECU connector as per table.

CTS Resistance Test		
ECU Pin		Specification
22	39	2280-2740Ω

7. If resistance value is correct, replace the ECU.
8. If resistance value is incorrect, repair the connectors or replace the wiring harness between ECU connector and the CTS.

Replacing the CTS

1. Disconnect the CTS connector and remove the CTS.
2. Install the new CTS and tighten to torque: 16 ± 2 Nm.
3. Reinstall remaining removed parts.

Installation

For installation, reverse the removal procedure.

CAUTION: Never use the gasket ring a second time. Always install a new one.

Torque temperature switch to 16 Nm (142 lbf.in).

Check coolant level in radiator and coolant tank and top up if necessary.

OIL COOLER

Removal

- Tilt cargo box.
- Loosen M6 bolts, then remove oil cooler mudguard.
- Remove clamps, then remove oil cooler pipe.
- Loosen M6 bolts, then remove oil cooler from mounting plate.

Inspection

- Check oil cooler fins for clogging or damage.
- Remove insects, mud or other obstructions with compressed air or low-pressure water.

Installation

For installation, reverse the removal procedure.

Tighten M6 bolts for oil cooler to 10-12N.m.

5. FUEL SYSTEM

5.1 FUEL TANK AND FUEL PUMP

STRUCTURE.....	5-1	DISMANTLING.....	5-1
FUEL PRESSURE TEST.....	5-2	FUEL FILTER.....	5-3
FUEL PUMP.....	5-3	FUEL SENSOR.....	5-3
FUEL TANK.....	5-3		

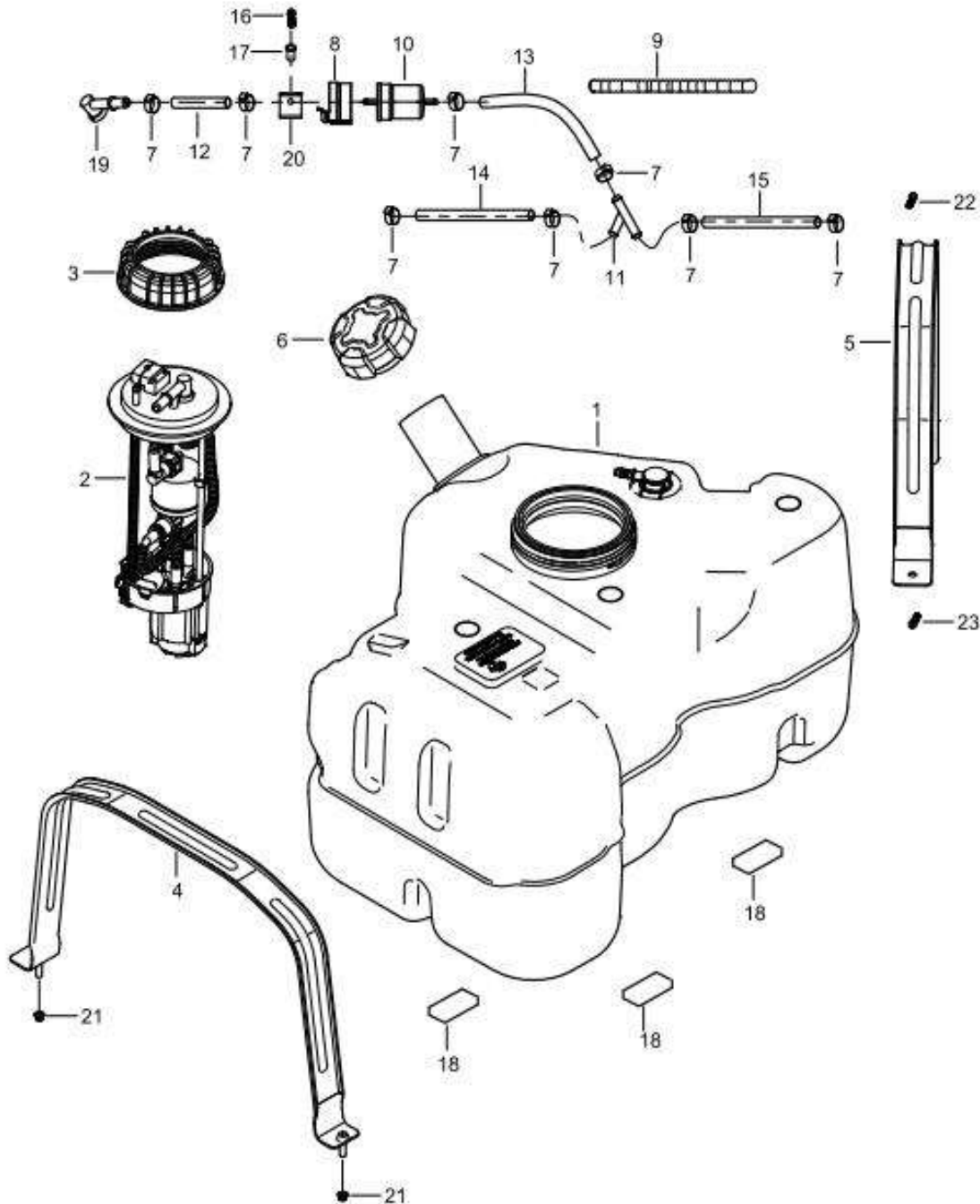

Names of components:

1.Fuel Tank	2.Fuel Pump	3.Fuel Pump Top Cover	4.Front Fuel tank Clamp	5.Rear Fuel tank Clamp
6.Tank Cap	7.Hose Clamp	8. Fuel Filter Rubber Sleeve	9. Fuel Hose Protection Spring	10. Fuel Filter
11. Y Type Copper Tee	12. Fuel Hose	13. Fuel Hose	14. Fuel Hose	15. Fuel Hose
16. M6 Bolt	17. M6 Rivet Nut	18. Fuel Tank Cushion	19. Fuel Hose Connector	20. Fuel Filter Mounting Plate
21. M8 Locking Nut	22. M8 Bolt	23. M6 Bolt		

GENERAL**⚠ WARNING**

Fuel is flammable and explosive under certain conditions. Ensure work area is well ventilated. Do not smoke or allow open flames or sparks in the vicinity.

⚠ WARNING

Always disconnect battery prior to working on the fuel system. Always disconnect battery exactly in the specified order, BLACK (-) cable first. It is recommended to disconnect electrical connections prior to disconnecting fuel lines.

Whenever working on fuel system, always verify for water or dust infiltration in reservoir.

During assembly/installation, use the torque values and service products as in the exploded views.

⚠ WARNING

Torque wrench tightening specifications must strictly be adhered to.

Locking devices (e.g.: locking tabs, elastic stop nuts, self-locking fasteners, cotter pin, etc.) must be installed or replaced with new ones where specified. If the efficiency of a locking device is impaired, it must be renewed.

⚠ WARNING

Replace any damaged, leaking or deteriorated fuel lines.

DISMANTLING

The fuel system of a fuel injection system holds much more a pressure than on carbureted vehicle. Prior to disconnecting a hose or to removing a component from the fuel system, follow the recommendation described here.

Fuel lines remain under pressure at all times. Always proceed with care and use appropriate safety equipment when working on pressurized fuel system. Wear safety glasses. Proceed with care when removing/installing pressure test equipment or disconnecting fuel line connections. Cover the fuel line connection with an absorbent shop rag. Slowly disconnect the fuel hose to minimize spilling. Wipe off any fuel spillage in the engine compartment. Do not allow fuel to spill on hot engine parts and/or electrical connectors. Never use a hose pincher on injection system high pressure hoses. Replace any damage or deteriorated fuel lines.

When the repair is completed, ensure that all hoses are connected and secured.

Always perform the fuel pressure test if any component has been removed. A pressure test must be done before turning the ignition key to ON and setting the engine stop switch to RUN. The fuel pump is activated each time in these conditions.

To locate a leak, pressurize the system. Check for leaking fuel or fuel odor. Spray soapy water on the hose connections and injectors. Air bubbles will show the leaking area.

Inspect the fuel lines, fuel tank, fuel tank cap for damage, clogging and leakage of fuel. If any damages are found, replace the defective parts with the new ones.

Fuel tank combination

1. Tilt cargo box. Disconnect wire group plug-in of fuel sensor, separating fuel sensor from wire group.

Note: Do not pull the plug directly when you pull it out. Press the plug by hand and pull it out at both ends.

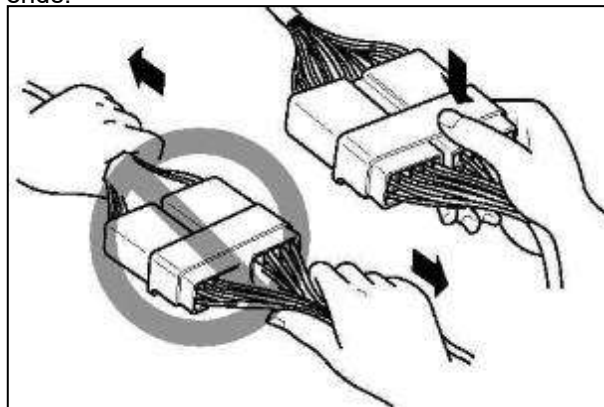
**⚠ WARNING**

Special attention should be paid to explosive gasoline.

2. Unplug the tubing and tank vent after releasing the hose clamp, and then loose the six screws on the oil pump cap. After completing the above steps, the oil pump can be removed from the tank for repair or replacement.



Note: Clamp should not be used repeatedly; new clamp should be used upon installation.

When pulling out fuel pipe, attention should be paid to pressure inside fuel pipe, splash proof measures should be taken and vessel should be prepared to discharge fuel inside fuel pipe in advance.

3. Loose the clamp and bolt for the throttle valve, unplug the relevant connector, and remove the throttle valve from the body for maintenance.

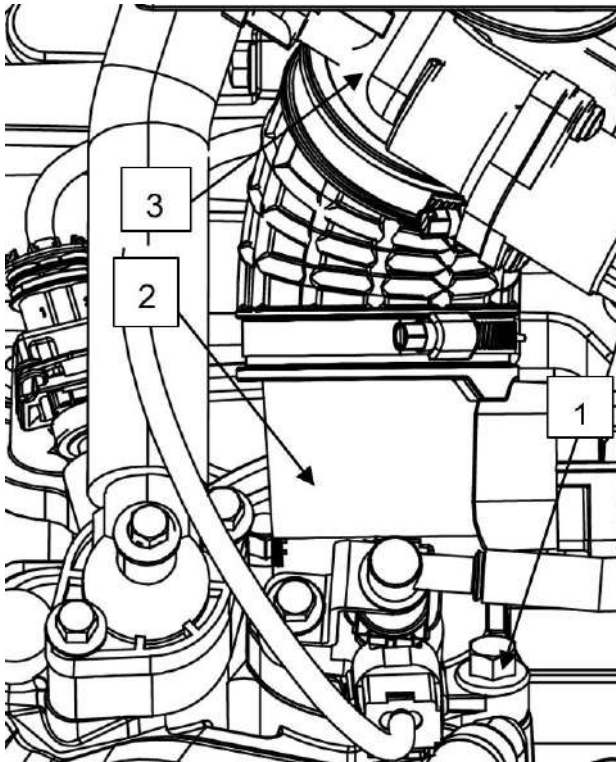
**TYPICAL**

1. 2xM8 bolt

2. Intake manifold

3. Throttle body

Tightening torque of M8 bolt for throttle valve: 22-30N.m

4. Unplug the high voltage coil and remove the spark plug with a tool.

Available overhaul:

Replace and conduct daily maintenance of spark plug.

5. After removing the screw with a screwdriver, open the throttle valve cover and remove the pin of the throttle cable head from the throttle cable. Then separate the throttle cable and throttle valve.

Available overhaul:

Replace and conduct daily maintenance of throttle valve combination and accelerator cable combination.

6. Disconnect cylinder fuel nozzle, crankshaft position sensor and starting motor plug-in separately.

Remove the hose clamp and pull out the fuel hose connected to the fuel injector.

Available overhaul:

Replace and conduct daily maintenance of fuel pipe.

Fuel pipe combination

Remove one screw, fuel filter support and fuel filter. The arrow on the fuel filter faces to the cylinder.

Note: Clamp should not be used repeatedly; new clamp should be used upon installation.

After completing dismantling fuel system, check fuel pipe, fuel filter and fuel pump filter element for block and crack. Replace the component with a new one, if necessary.

Installation

Conduct installation based on reversed sequence of dismantling.

▲ WARNING

To prevent fuel leakage, seal gasket, O-ring and ear clamp should be replaced upon installation. Fuel pipe should be replaced once every two years.

Do not smoke or near an open flame when performing maintenance on the fuel system.

INPECTION**FUEL PRESSURE TEST**

The pressure test will show the available pressure at the fuel pump outlet. It validates the pressure regulator, the fuel pump and leaks in the system.

Before proceeding to the pressure test ensure the battery is fully charged. Battery voltage must be over 12 volts.

Ensure there is enough gas in fuel tank.

Tilt cargo box.

Disconnect outlet hose.

Install fuel pressure gauge and T-fitting between disconnected hoses.

Turn ignition key ON and set engine stop switch to RUN and observe fuel pressure. Turn ignition key off then back on. Repeat the test.

**Standard fuel pressure: 350kpa.**

A rapid pressure drop indicates leakage is from the fuel rail, if there is not leaking then replace fuel pump.

A slow pressure drop indicates leakage either from the fuel injector or from the fuel pressure regulator. Check fuel injector and the fuel pressure regulator for leaks. If it is not leaking then replace fuel pump module.

If no leakage, start engine and observe fuel pressure. The fuel pressure should be the same as above.

If pressure is within limits, fuel pump and the fuel pressure regulator are working adequately.

Remove pressure gauge from inlet hose. Reconnect inlet hose.

PROCEDURES**FUEL HOSE AND CLAMP****Fuel Hose Replacement**

When replaced fuel hoses, be sure to use hoses and clamp as available from BIGHORN parts department. This will ensure continued proper and safe operation.

▲ WARNING

Use of improper fuel hoses could compromise fuel system integrity.

▲ WARNING

Whenever removing a hose in the fuel system, always use a new clamp at assembly. Then validate fuel tightness by performing a fuel pressure test.

Clamp Replacement

Use pliers to secure or cut clamps on fuel hoses.

FUEL FILTER

Replace fuel filter as per amintenance schedule.

Filter Removal

Remove oetiker clamps and pull hoses off. Detach filter from body.

Filter inspection

If fuel filter is suspected to be clogged, it may be checked as follows:

Using low compressed air, check if fuel filter is clogged. Air should flow easily through filter. In doubt, install a new filter.

Filter installation

Use arrow on filter to position it according to fuel flow.

FUEL PUMP**Fuel pump electrical test**

When turning ignition key ON, the fuel pump should run for 5 seconds to build up the fuel pressure in the system.

If the pump does not work, disconnect the connector from the fuel pump.

Install a temporary connector to the fuel pump connector. Apply 12V to this test harness.

CAUTION: Running the fuel pump a few minutes with reverse polarity can damage the pump.

If pump does not run, replace a new pump.

Other wise, check fuse and if good, probe terminals of fuel pump connector on vehicle harness or its connector, Repair or replace appropriate part.

Fuel pump removal

Remove fuel pump outlet hose and harness.

Remove fuel pump retaining screws.

Gently push pump up.

CAUTION: While pulling out the fuel pump, pay attention to fuel sensor float arm. Float arm can get stuck and bend which can reduce the fuel sensor capabilities.

Fuel pump installation

For installation, reverse the removal process but pay attention to the following.

Install a new gasket.

Pay attention to pump orientation.

Tighten retaining screws.

Install hose properly on OUT nipples and harness.

FUEL LEVEL SENSOR

The level sensor is part of the fuel pump module mounted inside the fuel tank.

Inspection

Dismantle the fuel pump module mounted inside the fuel tank (refer to above steps)

Turn on ignition switch.

Use hands to shake fuel sensor's floating device, locating floating device to see whether it is fit with indication of fuel meter.

Turn off the ignition switch and disconnect connector, measure resistance:

Lower: BLUE/WHITE:6-9Ω

Lift: BLUE/WHITE:90-95Ω

If the resistance is not within empty and full values, replace fuel pump module. If the fuel level sensor is good, try a new multifunction gauge.

Inspection

Install fuel sensor to fuel tank. Connect connector and hose. Turn on fuel supply switch, and check whether

Functions of fuel meter is normal or not.

Fuel leakage is not allowed.

FUEL TANK**Fuel tank draining**

Never perform this operation when the engine and/or the exhaust system is/are hot.

Never sue a hose pincher on injection system high pressure hoses.

Remove fuel tank cap and siphon gas in an approved fuel container.

Fuel tank removal

Remove the seat.

Tilt cargo box.

Remove the RH rear mudguard.

Remove the RH rear side panel.

Remove fuel pump from fuel tank.

Disconnect fuel hose from fuel tank.

Remove the fuel tank clamp, then remove fuel tank.

Fuel tank inspection

Inspect fuel tank for any damage or cracks which may result in fuel leaks. If so replace tank with a new one. Inspect tank and protector attachment points for damage. Inspect protector for damage.

Fuel tank installation

For installation, reverse the removal process but pay attention to the following.

Reconnect fuel pump connector and fuel hose.

Tighten retaining M8 bolts to 22~30N.m.

Refuel tank and ensure there are no leaks.

5.2 THROTTLE BODY

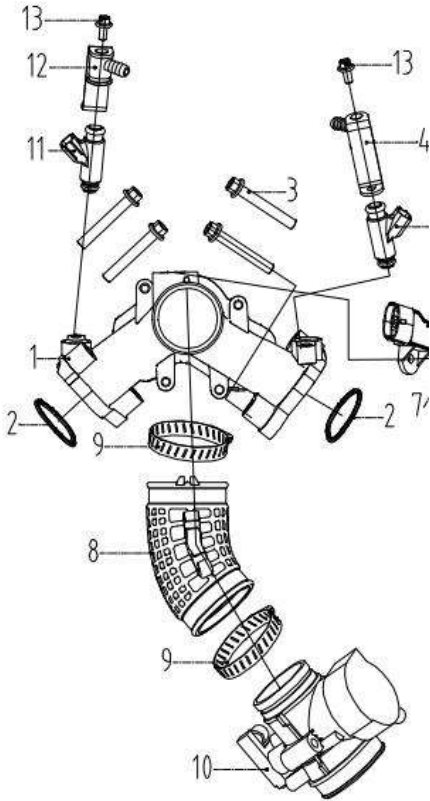

Names of components:

1. Air Intake Manifold	2. Gasket	3. M8 bolt	4. Va
7. Washer	8. Intake Neck	9. Clamp	10. bo
13. M6 bolt	14. Transmission heat shield	15. M8 bolt	16. hol

GENERAL

⚠️WARNING

When electrically disconnecting or removing the throttle body from the intake manifold, always turn off the engine and disconnect the battery.

⚠️WARNING

Always disconnect battery prior to working on the fuel system. Always disconnect battery exactly in the specified order, BLACK (-) cable first. Electrical connections should be disconnected prior to disconnecting fuel lines.

⚠️WARNING

Fuel is flammable and explosive under certain conditions. Wear safety glasses and work in a well-ventilated area. Do not smoke or allow open flames or sparks in the vicinity.

⚠️WARNING

Proceed with care and use appropriate safety equipment when working on the fuel system. Wipe off any fuel spillage in the engine. Do not allow fuel to spill on hot engine parts and/ or on electrical connectors.

Cover the fuel line connection with an absorbent shop rag before disconnecting them. Slowly disconnect the fuel hose to minimize spilling.

⚠️WARNING

Replace any damaged, leaking or deteriorated fuel lines or connections. After working on the fuel system, always pressurize the fuel system and check for fuel leaks. Refer to FUEL SYSTEM subsection.

BCM (Body Control Module)

The BCM controls the engine operation and the vehicle power management. To control the engine, the BCM reads the inputs from the sensors which it compares to predetermined parameters stored in the BCM (fuel and ignition maps), makes computations, and activates the outputs accordingly (injectors, ignition coils etc.).

EFI Sensors

To control the injection system, the engine management uses input signals from the following sensors:

- Crankshaft position sensor (CPS)
- Manifold absolute pressure and temperature sensor (MAPTS)
- Throttle position sensor (TPS) which is integrated to the throttle body (Electronic Throttle Control (ETC))
- Throttle accelerator sensor (TAS).
- Coolant Temperature Sensor (CTS)

Throttle Body ((ETC) Electronic Throttle Control)

Throttle Body

The throttle body is mounted on top of the intake manifold.

Air for combustion, drawn in by the engine, flows through the air intake system, then through the

throttle body where it is regulated by the throttle plate.

Fitted on the throttle body, an electronic throttle actuator (ETA) allows the ECU to electronically control the throttle plate opening which regulates the amount of air that enters the engine, and therefore engine torque.

There is no idle air control valve (IACV).

The TPS is also incorporated in the throttle body. It provides a signal to the ECU of the actual throttle plate position.

Fuel Injector

An injector is used to inject fuel into the intake pipe of the engine.

Fuel is injected in accordance with injection signals received from the BCM.

ADJUSTMENT

IDLE SPEED

Idle speed is not adjustable. The ECU (Engine Control Unit) controls the idle speed of the engine through the iTC system by controlling throttle plate opening using the ETA (electric throttle actuator).

The vehicle multifunction gauge can provide a readout of the engine's idle RPM.

Indicated engine RPM may be verified using the Diagnostic Tool.

NOTE: The gauge and Diagnostic Tool use the same signal to provide the engine RPM indication.

TROUBLESHOOTING

DIAGNOSTIC TIPS

Engine problems are not necessarily related to the fuel injection system.

It is important to ensure that the engine and propulsion system, fuel delivery and electrical systems are functioning normally.

For diagnostics purposes, use Diagnostic Tool.

After a problem has been solved, be sure to clear the fault(s) recorded in the ECU using the Diagnostic Tool.

⚠️WARNING

Electrical actuators and electronic modules may be powered up as soon as the START/STOP switch is depressed. Always disconnect the battery prior to disconnecting any electrical or electronic parts.

Never use a battery charger to temporarily substitute the battery as it may cause the ECU to function erratically, or not at all.

Check related-circuit fuse solidity and condition with an ohmmeter. A visual inspection could lead to a false diagnosis.

Poor Idling

If poor idling is experienced, check the following:

- Poor quality fuel or water in the fuel
- Fault codes using Diagnostic Tool
- Throttle body cleanliness
- Engine leaks or other mechanical problem.

Electrical Related Problems

It is important to check the following in the electrical system:

- Battery voltage
- Fuses
- Ground connections

- Wiring and connectors.

Ensure that all electronic components are original BIGHORN recommended components. Any modification to the wiring harness may lead to poor system operation or generate fault codes.

Electrical Connections

Pay particular attention to ensure that terminals and pins are not out of their connectors, corrosion, or out of shape.

When probing terminals, pay attention not to deform the terminals as this could cause a loose or intermittent connection that would be difficult to troubleshoot.

NOTE: Do not apply dielectric grease or other lubricants on the ECU connectors.

PROCEDURES

ENGINE CONTROL UNIT(ECU)

NOTE: As a first troubleshooting step, always check for applicable fault codes using Diagnostic Tool.

ECU Location

The ECU is located on the LH side of air filter housing.

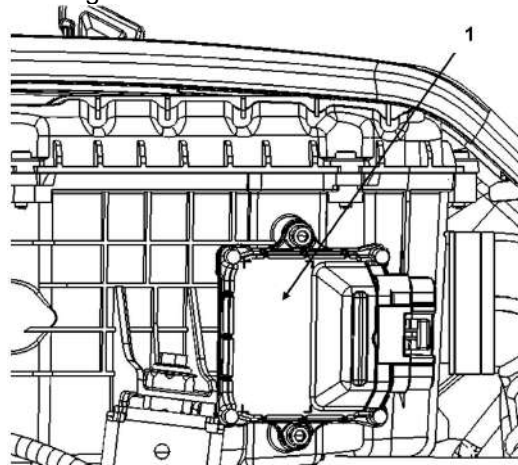

1.ECU

The ECU connectors have 48 pins.

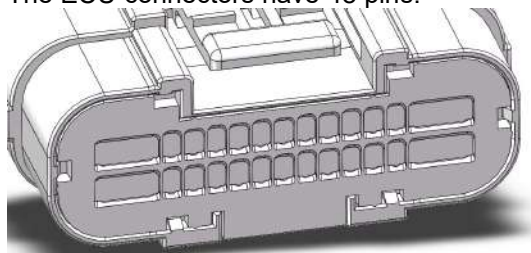

NOTE: For connector information, cleaning and probing.

OBD Location

The OBD is located under the operator's seat.

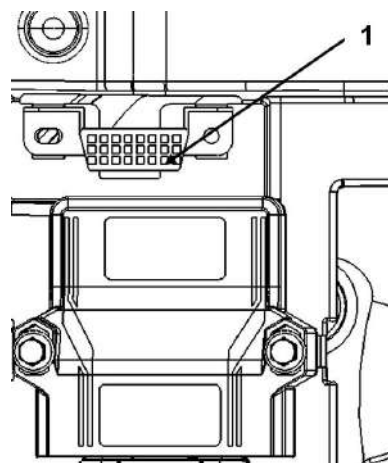

1.OBD

1.Remove the operator's seat, refer to BODY subsection.

2.Pull the OBD cover, then connect the Diagnostic Tool to OBD connector.

ECU Power Circuit Validation

Briefly press START/STOP switch.

This should wake up the ECU. The ECU will then activate relay for approximately 12 seconds after which it will turn off all power.

QUICK INDICATION THAT ECU IS POWERED (ASSUMING THE OBSERVED COMPONENT IS WORKING)
Multifunction gauge comes ON.
Fuel pump turns on for approx. 2 seconds

If ECU does not turn on, check the following:

- Fuse
- Battery voltage. Refer to CHARGING SYSTEM
- Relay
- START/STOP switch. Refer to ELECTRICAL SYSTEM
- ECU power circuit wires and ground wires.

For testing of fuses and relay, refer to POWER DISTRIBUTION subsection.

NOTE: When relay is not working, the EMS (engine management system) and the complete vehicle electrical system will not be powered.

ECU Wake Up Circuit Test

- 1.Use a multimeter and select Vdc.
2. While pressing START/STOP switch, read voltage as follows.

ECU Pin	Battery	VOLTAGE
Pin 5 (Black)	Positive Terminal	Battery Voltage

If voltage is as per specification, refer to ECU POWER CIRCUIT TEST.

If voltage is out of specification:

- Test the START/STOP switch, refer to ELECTRICAL SYSTEM subsection.
- If START/STOP switch tests good, test wiring and connectors from battery to ECU. Refer to WIRES DIAGRAM.

ECU Power Circuit Test

1. Remove the operator's seat.
2. Install an appropriate fused jumper wire between the following terminals on the ECU.

JUMPERWIRE COORDINATES ON ECU

Pin 14 (Light green/yellow)	EFI Relay, EFI Fuse
--------------------------------	---------------------

NOTE: When the jumper is installed, the multifunction gauge should come on.

If the multifunction gauge did not come on, check the following:

- Fuses
- Relay
- Wiring between ECU contact Pin14 and fuse
- ECU ground circuit, refer to CONTINUITY TEST OF ECU GROUND CIRCUITS in this subsection.

For testing of fuses and relay, refer to POWER DISTRIBUTION subsection.

If gauge came on, carry on with the following step.

3. Remove fuse
4. Set multimeter to Ω.
5. Check resistance as follows.

ECU	BATTERY	READING
PIN	TERMINAL	Ω
Pin 14 (Light green/yellow)	Negative (Ground)	Close to 0 Ω

If voltage is not measured, check the wiring and connections between ECU and fuse, refer to the WIRES DIAGRAM subsection.

If all items mentioned in this test and in ECU WAKE UP CIRCUIT TEST tested good, try a new ECU.

Continuity Test of ECU Ground Circuits

1. Set multimeter to Ω and probe adapter terminals as per following table.

OBD	BATTERY	READING
PIN	TERMINAL	Ω
Pin4(Black)	Negative (Ground)	Close to 0 Ω
Pin5(Black)		

If any measurement is out of specification refer to POWER DISTRIBUTION subsection and check the following:

- Wiring and connections
- Engine ground
- Battery ground
- Frame ground.

ECU CAN Line Test

CAN lines link the ECU, multifunction gauge and OBD.

Test CAN wire continuity as follows.

1. Disconnect ECU connector.
2. Disconnect multifunction gauge connector. Refer to ELECTRICAL SYSTEM subsection.
3. Check wire resistance as follows.

OBD	ECU	MEASUREMENT
Pin5(Black)	Pin 5(Black)	Close to 0 Ω

If continuity is out of specification, repair or replace wiring harness between ECU and OBD.

If continuity is as per specification, carry out the following test.

4. Read wire resistance as follows.

ECU	Gauge Connector	Measurement
Pin 29 (Light green)	Pin 21 (Light green)	Close to 0 Ω

If continuity is out of specification, repair or replace wiring harness between ECU and multifunction gauge.

If continuity is as per specification, CAN lines are functional.

Reconnect connectors and reinstall removed parts.

ECU Removal

NOTE: If a new ECU is to be installed, first read the procedures in ECU REPLACEMENT in this subsection.

1. Disconnect battery cables.

NOTICE: Always disconnect the BLACK negative (-) battery cable first, then disconnect RED positive (+) cable.

2. Refer to BODY subsection and remove the LH side panels.

3. Disconnect ECU connectors from ECU.

4. Remove M6 bolts and remove the ECU from its support.

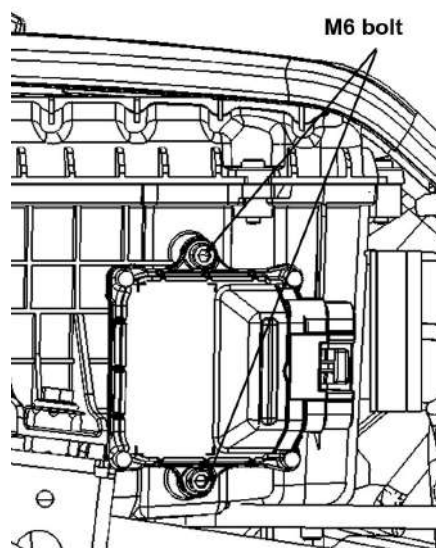

ECU Installation

1. Reverse removal procedure. Tightening of M6 bolts for ECU to torque: 9-12Nm.
2. Reconnect ECU connectors.
3. Reconnect battery cables.

⚠ WARNING
Always reconnect the RED positive (+) battery cable first, then reconnect BLACK negative (-) cable.

4. If a new ECU is installed, refer to ECU REPLACEMENT in this subsection.

NOTICE: Always replace ECU by the same part number.

ECU Replacement

NOTE: Prior to replacing an ECU, ensure that all the recommendations in the general introduction of this subsection have been followed and all applicable testing procedures have been carried out.

When the ECU is replaced, data must be entered

into the new ECU.

FUEL INJECTOR

Fuel Injector Removal

1. Tilt the rear cargo box.

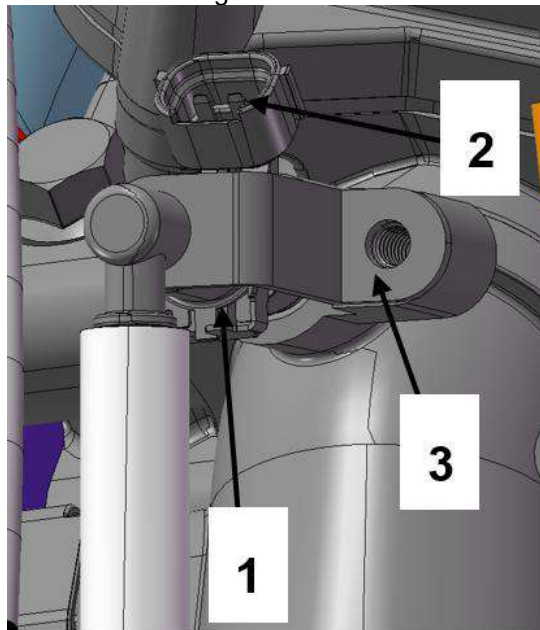

1. Fuel Injectors
2. Fuel Injector connectors
3. M8 bolt

2. Disconnect the fuel injector connectors.
3. Loosen M8 bolt, then remove the fuel injector.
4. Loosen the clamp, separate the fuel injector and fuel hose.
5. Loosen M6 bolts, remove the injection valve cap from fuel injector.

Fuel Injector Operation Test with Diagnostic Tool (Dynamic)

1. Connect Diagnostic Tool to OBD.
 2. Start engine.
 3. In Diagnostic Tool, click the following:
 - Function page
 - ECU button
 - Activate Fuel Injectors.
 4. Using the Diagnostic Tool, shut down engine cylinder one at a time by clicking on the button under the applicable cylinder.
- If the engine RPM drops when clicking on a cylinder, the injector and the ignition of this cylinder are functioning normally.
- If the engine RPM does not drop when clicking on a cylinder, this cylinder is not functioning properly. Check the following:
- Fuel injector operation. Refer to FUEL INJECTOR OPERATION TEST WITH Diagnostic Tool (STATIC).
 - Spark plug and ignition coil. Refer to IGNITION SYSTEM.
 - Engine condition.

Fuel Injector Operation Test with Diagnostic Tool (Static)

NOTICE: After fuel injector activation using Diagnostic Tool, always crank engine in drowned mode to ventilate engine and prevent a potential backfire due to fuel accumulation in the engine.

1. Connect Diagnostic Tool to OBD.

2. In Diagnostic Tool, click the Read Data button to read the new ECU.
3. On the Activation page of Diagnostic Tool, energize the fuel injector to be tested. You should hear the inject or functioning. This will validate the inject or mechanical and electrical operation. If the inject or does not function, carry out the FUEL INJECTOR RESISTANCE TEST.

Fuel Inject or Balance Test

NOTICE: After fuel inject or activation using Diagnostic Tool, always crank engine in drowned mode to ventilate the engine of fuel.

1. Install a fuel pressure gauge as described in FUEL PUMP PRESSURE TEST subsection.
2. Connect Diagnostic Tool to OBD.
3. In Diagnostic Tool. select the following:
 - Function page
 - ECU button
 - Activate Fuel Pump.
4. In Diagnostic Tool, click on the Fuel Pump button to activate fuel pump.
5. Fuel pressure must be within specification. Refer to FUEL TANK AND FUEL PUMP subsection. Reactivate fuel pump as necessary.
6. In Diagnostic Tool, select a fuel injector to energize it.
7. Record the fuel pressure drop for injector.
8. Repeat for all fuel injectors.
9. The maximum fuel pressure drop between injectors should not exceed the following specification:

Maximum Fuel Pressure Drop Allowed Between Fuel Injector
10kPa (1.5 Psi)

If the pressure drop between fuel injectors is greater than the specification, replace the inject or with the least pressure drop, then repeat the test.

11. Using the valve on the fuel pressure gauge, release the pressure in the system (if so equipped).
12. Remove fuel pressure gauge and reinstall removed parts.
13. Set engine emergency off switch to OFF.
14. Crank engine in drowned mode (accelerator held all the way in) to ventilate the engine of the fuel that was injected during the test.

WARNING

Always crank engine in drowned mode to ventilate all fuel that was injected during the test. Failure to do so may result in severe engine damage and injury.

Fuel Inject or Leakage Test

Test Setup

1. Ensure there is enough fuel in fuel tank.
2. Ensure fuel pressure from fuel pump is within specification. Refer to FUEL TANK AND FUEL PUMP subsection.

NOTE: Keep the pressure gauge installed for the leakage test.

3. Set engine emergency stop switch to STOP.

WARNING

The engine emergency stop switch is set to STOP to prevent any spark in the engine

compartment should the engine be cranked. Fuel vapors may ignite in presence of a spark creating a fire hazard.

4. Disconnect the vehicle from Diagnostic Tool by disconnecting the POWER INTERFACE from the vehicle diagnostic connector.
5. Wait for vehicle electrical power to shut off; the multifunction gauge will turn off.
6. Remove fuel hose with injectors from engine.
7. Position fuel hose so that an appropriate container may be placed under the injectors to collect any fuel leakage.
8. Connect vehicle to Diagnostic Tool.

Leakage Test

1. In Diagnostic Tool, select the following:
 - Activation page tab
 - ECU page.
2. Click on the Fuel Pump button to activate fuel pump for a few seconds.
3. Check for fuel leakage from the injector nozzles.
4. Monitor fuel pressure at fuel pressure gauge. If pressure drops below 372kPa (54 PSI) during the test, reactivate fuel pump as necessary.

Fuel Injector Leakage	
Test Duration	Specification
2 minutes	1 drop per minute maximum

If test is not within specification, replace the faulty fuel injector.

5. Properly reinstall fuel rail. Refer to FUEL RAIL in this subsection.
6. Reinstall remaining removed components.

WARNING

Wipe up any spilled fuel.

Fuel Injector Resistance Test

1. Ensure vehicle electrical power is off, remove fuse.
3. Remove cover from the front fuse box and locate fuse.
4. Check resistance value between fuse box and ECU connector terminals as follows.

ECU	Fuse box	READING
PIN	Terminal	Ω @ 20°C (68°F)
Pin8 (Brown/yellow)	EFI relay	0 Ω

If resistance value obtained is correct, carry out a FUEL INJECTOR INPUT VOLTAGE TEST.

If resistance value obtained is incorrect, remove injector connector and check resistance value between injector pins as follows. Refer to FUEL INJECTOR ACCESS in this subsection.

INJECTOR		Resistance
PIN		Ω @ 20°C (68°F)
Pin A (Brown/yellow)	Pin B (Grey/yellow)	12 ± 0.6 Ω
Pin A (Brown/yellow)	Pin B (Blue/white)	12 ± 0.6 Ω

If resistance is out of specifications, replace injector.

Fuel Injector Input Voltage Test

1. Ensure ECU connector is properly connected.
2. Disconnect the fuel injector connector. Refer to FUEL INJECTOR CONNECTOR ACCESS in this subsection.

NOTE: Press against tab underneath connector as illustrated to unlock it.

3. Ensure fuse is properly installed.
 4. Set engine emergency stop switch to STOP to prevent engine starting.
 5. Momentarily press the START/STOP switch to wake up the ECU.
- NOTE:** It is not necessary to activate the injector since it is continuously powered when the ECU is awake.

8. Use a multimeter and set it to Vdc. Read voltage.

INJECTOR	BATTERY	READING
WIRE	TERMINAL	VOLTAGE
Brown/yellow	Battery Ground	Battery voltage

If inject or input voltage is good, carry out the following:

- Circuit continuity test between injector and ECU, refer to WIRES DIAGRAM subsection.
- FUEL INJECTOR SIGNAL TEST further in this subsection.

If inject or input voltage is not good, check the following:

- Fuse
- Circuit continuity between fuse and injector. Refer to POWER DISTRIBUTION and WIRES DIAGRAM subsections.

Fuel Injector Installation

For the installation, reverse the removal procedure however, pay attention to the following details.

NOTICE: If installing the removed inject or(s), ensure inject or O-rings are in good condition. Replace O-rings as required.

1. Apply a thin film of engine oil to O-rings to ease insertion in rail.
2. Install fuel inject or with your hand. Do not use any tool.
3. Ensure proper positioning of the intake manifold O-ring on inject or as in following illustration.
4. Carefully insert injector in air intake manifold paying attention to the manifold O-ring.

NOTICE: Gently push O-ring in evenly all around while inserting injector. O-ring must be completely inserted and not visible, before completing the insertion of the injector.

5. Firmly push injector until it bottoms out.
6. Install the injection valve caps. Tighten the M6 bolts for injection valve cap to 9~12Nm.
7. Install fuel hose.
8. Apply engine oil on O-rings of fuel pressure hose fitting.
9. Connect the fuel injector connector. Pressurize the fuel system and check for fuel leaks. Refer to FUEL SYSTEM PRESSURIZATION in FUEL TANK AND FUEL PUMP subsection.

WARNING

Failure to pressurize the fuel system and checking for fuel leaks may result in severe injury or a life threatening situation should a leak occur.

8. Reinstall all remaining removed parts.

THROTTLE BODY (ETC (ELECTRONIC THROTTLE CONTROL))

Throttle Body (ETC) Description



- 1. Throttle body
- 2. Throttle plate
- 3. Electronic throttle actuator (electric motor inside)
- 4. Throttle position sensor (TPS) (inside)

Electric Throttle Actuator (ETA)

The electric throttle actuator (ETA) is a DC motor on the throttle body that regulates the throttle plate via a drive gear. It receives its control signal from the ECU. Pulse width modulation (PWM) is used to control the motor.

Throttle Plate Operating Positions

Two torsional springs are connected to the throttle plate. A main spring and another one in a plunger mechanism.

When there is no power to the throttle actuator (ETA), the plunger mechanism maintains the throttle plate at a rest position. This also serves as the limp home position.

When the throttle plate is opened by the ETA as commanded by the ECU, it acts against the main spring. If the ETA failed, the return spring would bring the throttle plate back to the limp home position.

Throttle Body (ETC) Faults and Effects

NOTE: Among other things, a weak or broken spring and a sticky throttle plate are validated by the throttle body diagnostic mode.

FAULT	EFFECT
Partial failure of TAS sensor (One internal sensor only)	Limp home mode. Engine speed limited to idle. ECU will use the remaining TAS sensor. Fault code set and beeper activated to emit warning signals. Check engine light is turned ON. Drivability could be reset by releasing and reapplying the throttle.
Complete failure of TAS sensor (Both internal sensors)	Limp home mode. Engine speed limited to 2500 RPM. Fault code set and beeper activated to emit warning signals. Check engine light is turned ON.

Any throttle body failure	Limp home mode. Engine speed limited to 2500 RPM. Engine speed can still be increased up to 3200 RPM using the throttle lever. Fault code set and beeper activated to emit warning signals. Check engine light is turned ON.
---------------------------	--

NOTE: Refer to FAULT CODES and INTELLIGENT THROTTLE CONTROL (iTC) subsections for more informations.

Throttle Body (ETC) Access

Tilt the cargo box.

Throttle Body (ETC) Lubrication

No lubrication is required.

Electric Throttle Actuator (ETA) Test

Electric Throttle Actuator (ETA) Test with Diagnostic Tool

1. Connect Diagnostic Tool to OBD
2. Press the START/STOP button to wake up the ECU.
3. In Diagnostic Tool, select:
 - Read Data button
 - Setting page tab.

NOTE: Use the Setting page to confirm ETA movement. The Monitoring page will not read the actual ETA movement.

4. Slowly depress the throttle pedal from the idle to WOT. The ETA should go from almost 10% to 100%. If result is out of specification, carry out a THROTTLE POSITION SENSOR INITIALIZATION. Refer to THROTTLE POSITION SENSOR (TPS) in this section.

NOTE: The ETA is reset at the same time as the TPS.

After the reset, test ETA again.

If the result is still out of specification, check wire continuity between ECU and throttle body before assuming the ETA is at fault.

Throttle Body (ETC) Inspection

1. Remove parts required to access throttle body, refer to THROTTLE BODY (ETC) ACCESS.
2. Carry out the following:
 - Inspect throttle body for cleanliness.
 - Ensure throttle plate opens fully and smoothly.
 - Check for corrosion or damaged wiring or damaged ETC connectors.

Throttle Body (ETC) Dynamic Tests

1. Remove the parts required to access the throttle body (ETC), refer to THROTTLE BODY (ETC) REMOVAL.
2. Remove the air inlet hose from the throttle body.
3. Observe the throttle plate with the engine stopped.

NOTE: The throttle plate should be in the rest position (slightly opened).

⚠ WARNING
Keep your fingers out of the throttle plate area while the ECU turns on. The throttle actuator will cycle. This could cause serious finger injuries as throttle plate quickly moves.

4. As you observe the throttle plate, have someone press the START/STOP switch to wake up the ECU.

NOTE: The throttle plate should cycle quickly from the rest position to a partially open position (approximately 15°), then back to the rest position.

5. As you observe the throttle plate, have someone gradually and evenly pull in the throttle lever, then release it in the same way.

NOTE: The throttle plate should open then close according to throttle lever position however, the movement of the throttle plate may not be linear with the displacement of the throttle lever.

If any test failed, proceed with the THROTTLE BODY (ETC) STATIC TESTS.

Throttle Body (ETC) Static Tests

⚠WARNING

First ensure the ECU is off. Do not move the throttle plate using your fingers. Otherwise, should the START/STOP switch be pressed, the ECU would turn on and quickly cycle the throttle plate which could cause serious finger injury.

1. Using a blunt tool, push in on the throttle plate and ensure it opens smoothly within the throttle body.

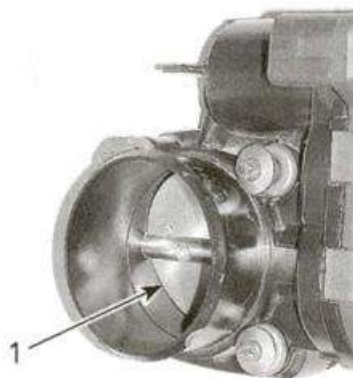

1. Push here to open

NOTE: The throttle plate must open fully and return freely to the rest position (slightly opened) when released.

2. Push throttle plate to close throttle body. It must close completely and return freely to the rest position (slightly opened) when released.

If the throttle plate does not move smoothly or does not return freely to the rest position, the problem is mechanical. Check for dirt accumulation on throttle plate shaft. It may also be an actuator or gear problem. Replace throttle body as necessary.

If throttle plate operates normally, the problem is electrical. Check electric throttle actuator (ETA) wiring continuity, throttle position sensor (TPS) and throttle accelerator sensor (TAS).

⚠WARNING

If the throttle plate does not return to its rest position properly after a proper cleaning, replace the throttle body.

Throttle Body (ETC) Cleaning

1. Remove throttle body from intake manifold. Refer to THROTTLE BODY (ETC) REMOVAL in this subsection.

2. Check throttle body cleanliness using a flashlight. Fully open throttle plate and verify:

- Throttle body bore
- Throttle plate edge.

Look for:

- Dirt
- Oily surfaces
- Carbon and dirt deposits on throttle plate and the surrounding bore.

3. Clean as necessary.

4. Use a throttle body cleaner such as GUNK INTAKE MEDIC or an equivalent.

NOTICE: Only use an appropriate throttle body cleaner that will not damage O-rings and EFI sensors.

CAUTION: Use the product in a well-ventilated area. Refer to product manufacturer's warnings.

5. To avoid getting dirt into engine, spray cleaner on a clean rag then rub rag against throttle plate and bore. A toothbrush may also be used.

CAUTION: Ensure ignition key is removed and battery cables are disconnected so that nobody can activate the electrical system, otherwise the ECU would turn on and the throttle actuator (ETA) would cycle. This could cause serious finger injury as the throttle plate moves quickly.

6. Gently open throttle plate and hold fully open to clean all surfaces.

7. To remove residual dirt, spray cleaner on throttle plate and throttle bore.

8. Reinstall all removed parts.

Throttle Body (ETC) Removal

⚠WARNING

When electrically disconnecting or removing the throttle body from the intake manifold, always remove ignition key and disconnect the battery.

1. Remove parts required to access throttle body, refer to THROTTLE BODY (ETC) ACCESS.

2. Detach throttle cable from handlebar.

3. Disconnect ETA and TPS connectors.

4. Loosen M8 bolts, then remove throttle body from intake manifold.

5. Gently move throttle body away to detach throttle cable.

6. Remove throttle body cover.

7. Detach throttle cable.

Throttle Body (ETC) Installation

Installation of the throttle body is the reverse of the removal procedure. However, pay attention for the following details.

1. Properly install cable barrel to throttle cable end.

2. Do not reinstall cover yet.

3. Install throttle body on intake manifold.

4. Install throttle body to handlebar.

5. Depress throttle lever several times to ensure it properly returns.

6. Perform the THROTTLE POSITION SENSOR INITIALIZATION reset procedure. Refer to THROTTLE POSITION SENSOR (TPS) in this subsection.

7. Install all remaining removed parts, refer to applicable subsections.

8. Start engine and ensure proper idle and throttle control.

THROTTLE POSITION SENSOR (TPS)

TPS Description

NOTE: The TPS is part of the throttle body (ETC).

The throttle position sensor (TPS) is a double

potentiometer that sends signals to the ECU that are proportional to the throttle plate angle.

NOTE: As a first troubleshooting step, always check for applicable fault codes using Diagnostic Tool.

Throttle Position Sensor Initialization

NOTE: The TPS initialization procedure must be carried out whenever the throttle body (ETC) is replaced, unless an ECU first initialization reset is carried out.

This operation performs a reset of the TPS basic values in the ECU. This reset is very important as the TPS values are part of the basic parameters for all fuel mapping calculations and control of several settings such as for idle speed and maximum RPM of the engine.

NOTICE: An improperly set TPS may lead to improper idle speed (too low or too high), poor engine performance, poor engine starting and engine stop on deceleration, fault codes and possible engine damage. Emission compliance may also be affected.

1. Connect Diagnostic Tool to OBD.
2. In Diagnostic Tool, select the following:
 - Read Data button
 - Setting tab
 - ECU tab.
3. Ensure the throttle lever is fully released and at the idle position.
4. In the Throttle position sensor initialization field, click on the Throttle Opening Reset button.

A message will be displayed if the operation is successful.

If an error occurred or the TPS is not within the allowed range while resetting, the ECU will generate a fault code and will not accept the setting.

5. If a fault message is displayed, follow the instructions in the message(s).
6. Check for fault codes.
7. If a fault code is generated,
 - Carry out the service actions.
 - Reset the fault.
 - Repeat the reset procedure.
8. Start engine and make sure it operates normally throughout its full engine RPM range.

TPS Wear Test

1. With the engine turned off, slowly press on the throttle lever and pay attention for smooth operation without physical stops.
2. Activate the electrical system to wake up the ECU.
3. Connect Diagnostic Tool to OBD.
4. In Diagnostic Tool, select the following:
 - Monitoring tab
 - ECU tab.
5. Slowly and regularly move the throttle lever.
6. Observe the Throttle Opening indication movement in Diagnostic Tool.

NOTE: The indication should move gradually and regularly as you move the throttle lever. If the TPS indication is erratic or suddenly drops off, it may indicate a worn TPS that needs to be replaced. An initial slight delay after the throttle lever is moved and before the indication starts to move is normal. If the indication behavior is not as expected,

proceed with the following steps.

7. Manually move the throttle plate in the throttle body using a blunt tool (without sharp tip).

CAUTION: Do not move throttle plate with your fingers. Otherwise, if ECU should turn off, it would quickly close the throttle plate which could cause finger injury.



1. Push here

8. Check the indication movement again.
 - If the indication moves as expected, check the throttle accelerator sensor (TAS). Refer to THROTTLE ACCELERATOR SENSOR (TAS) in this subsection.
 - If the indication does not move as expected, perform the TPS RESISTANCE TEST in this subsection.

TPS Voltage Test

Check the ECU voltage output to the TPS.

Disconnect connector from TPS.

Turn ignition key ON and set engine stop switch to RUN.

Check the voltage reading from harness connector as following.

Connection	Voltage
Pin A with battery ground	5.0V
Pin B with battery ground	0 V
Pin C with battery ground	4.75~ 5V

If voltage test is not good, check/repair wiring harness. If wiring test good, refer to ECU REPLACEMENT.

If voltage test is good, everything is order (assuming resistance test was performed).

Replacement

Remove throttle body. Refer to BODY.

Loosen two screws retaining TPS.

Remove TPS.

Install the new TPS.

Apply Loctite 243 on the TPS retain screws, then torque to 9Nm.

Reinstall remaining removed parts.

CRANKSHAFT POSITION SENSOR (CPS)

CPS TROUBLESHOOTING

When troubleshooting a CPS fault, take into account that a CPS fault can be triggered by bent or missing encoder wheel teeth.

Push START/STOP switch and crank engine. If engine does not start within 15 seconds check for fault codes using Diagnostic Tool.

CPS Access

1. Tilt cargo box.

CPS Resistance Test at ECU connector

- 1.Remove parts required to access ECU connector, refer to ECU CONNECTOR ACCESS.
- 2.Disconnect ECU connector from ECU.
3. Set multimeter to Ω.
4. Measure the resistance of the sensor as per following table.

ECU BLACK		READING
PIN		Ω@ 20°C (68°F)
4	13	775 - 950 Ω

If resistance is as specified, test continuity of wiring between ECU and CPS connectors. Refer to WIRES DIAGRAM subsection.

If resistance value is not as specified, reconnect ECU connector to the ECU and refer to CPS RESISTANCE TEST AT CPS CONNECTOR.

CPS Resistance Test at CPS Connector

1. Cut locking tie securing CPS connector to ECU support and disconnect CPS connector.
2. Probe CPS connector terminals as per following table.

CPS		READING
PIN		Ω@ 20°C (68°F)
1	2	775 - 950 Ω

If resistance is not within specifications, replace the CPS.

If resistance tests good, carry out a CPS OUTPUT VOLTAGE TEST.

CPS Output Voltage Test

1. Remove fuse.
2. Cut locking tie securing CPS connector to ECU support and disconnect the CPS connector.
3. Probe CPS connector terminals while cranking engine as per following table.

CPS		READING
PIN		VOLTAGE
1	2	1 - 2 Vac min.

If voltage is out of specification, inspect wiring/connectors. Replace CPS if wiring is good.

If voltage is within specification, the problem may be related to the ECU.

4. Reconnect CPS connector and install all removed parts.

CPS Replacement

1. Remove parts required to access the CPS, refer to CPS ACCESS in this subsection.
2. Take note of factory CPS wire harness routing for reinstallation.
3. Cut harness locking ties and disconnect CPS connector.
4. Remove CPS retaining screw and pull on CPS to remove it.
5. Install new CPS.

CPS INSTALLATION	
O-RING	SERVICE PRODUCT
	APPLY ENGINE OIL ON O-RING
RETAINING SCREW	TORQUE
	9~12Nm

6. Route and secure CPS harness using harness clamp and locking ties as noted prior to removal.

MANIFOLD ABSOLUTE PRESSURE AND TEMPERATURE SENSOR (MAPTS)

NOTE: This sensor is a multifunction device. It measures manifold absolute pressure and intake temperature for air flow calculations.

MAPTS Access

Tilt cargo box.

MAPTS Pressure Function

Before the engine is started, when power is applied to the system, the sensor measures the ambient air atmospheric pressure. The ambient pressure is, at that moment, stored in the ECU.

Thereafter, once the engine is started, it measures the air pressure in the intake manifold at operating RPMs.

The sensor must be correctly installed on the intake manifold. Otherwise, the MAPTS could generate a fault code for an unexpected sensor range at idle when it reads the atmospheric pressure. If this is the case, remove sensor and check for oil or dirt on its end and if problem persists, check throttle plate condition/position and the wiring harness. Perform the following tests.

MAPTS Quick Test (Pressure Function)

1. Connect Diagnostic Tool to OBD.
2. In Diagnostic Tool, select the following:
 - Read Data
 - Monitoring page tab
 - ECU page.

3. Look for and take note of the MAPTS pressure reading while the engine is stopped.

NOTE: The indicated intake air pressure in Diagnostic Tool must be within 3.4kPa (0.5PSI) of local atmospheric pressure when the engine is stopped.

MAPTS PRESSURE FUNCTION QUICK TEST			
RESULT	SERVICE ACTION		
NO READING	Circuit Continuity Test of MAPTS Pressure Function	MAPTS Input Voltage Test	Repair or replace wiring
VALUE IS OUT OF RANGE	Replace MAPTS		

4. Perform the same test with a new MAPTS and compare both readings.

MAPTS Input Voltage Test

1. Remove parts required to access the Misrefer to MAPTS ACCESS.

- Remove electrical connector from MAPTS.
- Briefly push START/STOP switch.
- Set multimeter to Vdc, measure for MAPTS input voltage as per following table.

MAPTS		READING
PIN		VOLTAGE
A	D	5 Vdc

If voltage test is good, replace the MAPTS.

If voltage test is not good, carry out the MAPTS CIRCUIT CONTINUITY TEST (PRESSURE FUNCTION).

MAPTS Circuit Continuity Test (Pressure Function)

- Remove parts required to access ECU connectors, refer to ECU CONNECTOR ACCESS in this subsection.
- Disconnect the ECU-A connector from the ECU and connect it to the ECU adapter tool.
- Set multimeter to Ω and check continuity of the following circuits.

ECU Black	MAPTS	READING
PIN		Ω
Pin 16	Red/White	Close to 0 Ω
Pin 10	Green	
Pin 11	Black/Brown	

If resistance is not within specification, repair or replace the wiring harness between ECU connector and the MAPTS. Refer to WIRES DIAGRAM.

MAPTS Temperature Function

The MAPTS also monitors the temperature of the air in the intake manifold.

MAPTS Quick Test (Temperature Function)

- Connect Diagnostic Tool to OBD.
- In Diagnostic Tool, select the following:
 - Read Data
 - Monitoring page tab
 - ECU page.
- Look for the Intake Air temperature reading while the engine is stopped.

NOTE: If the complete vehicle is at room temperature, Diagnostic Tool should display the ambient air temperature at the intake manifold.

- Perform the same test with a new MAPTS and compare both readings.

If the engine's MAPTS temperature reading is significantly different than the new MAPTS, replace it.

NOTE: Both sensors must feel same ambient air temperature.

If there is no reading, carry out a MAPTS RESISTANCE TEST (TEMPERATURE FUNCTION).

MAPTS Resistance Test (Temperature Function)

- Disconnect the MAPTS connector.
- Test MAPTS resistance at the sensor as per following tables.

MAPTS		READING
PIN		Ω
A	D	Refer to MAPTS TEMPERATURE SENSOR TABLE

MAPTS TEMPERATURE SENSOR TABLE		
TEMPERATURE		Ω
$^{\circ}\text{C}$	$^{\circ}\text{F}$	MAPTS
- 40	- 40	40528 to 56935
- 10	- 14	8103 to 10919
20	68	2193 to 2863
80	176	294 to 368
120	248	98 to 122

If resistance is not within specification, replace the MAPTS.

If resistance tests good, reconnect the MAPTS and proceed with the following steps.

- Using a multimeter, recheck resistance value as per following table.

ECU Black		READING
PIN		Ω
Pin 8	Pin 10	Refer to MAPTS TEMPERATURE SENSOR TABLE

MAPTS TEMPERATURE SENSOR TEST RESULTS

RESULT	SERVICE ACTION		
NO READING	Circuit Continuity Test of MAPTS Temperature Function	MAPTS Input Voltage Test	Repair or replace wiring
INCORRECT RESISTANCE VALUE	Check condition of connector pins, replace MAPTS		
CORRECT RESISTANCE VALUE	Try a new ECU		

MAPTS Circuit Continuity Test (Temperature Function)

ECU Black	MAPTS	READING
PIN		Ω
Pin 8	A	Close to 0 Ω
Pin 10	D	

Repair or replace wiring as required.

MAPTS Replacement

- Disconnect MAPTS connector and remove the MAPTS from the intake manifold.
- Install new MAPTS as per following table.

MAPTS Retaining Screw	
Tightening torque	9 ~12 Nm

COOLANT TEMPERATURE SENSOR (CTS)

Overheat Warning

The CTS will cause the engine overheat warning to come on when the coolant temperature is above 110°C(230°F).

CTS Access

The CTS is located on the RH side of the engine, between the water pump and oil cooler.

To access the CTS, remove the RH side panel.

CTS Quick Test

1. Connect Diagnostic Tool to OBD.
2. In Diagnostic Tool, select the following:
 - Read Data button
 - Monitoring page tab
 - ECU page.

3. Look for the engine temperature indication.

The engine temperature gauge in Diagnostic Tool should provide an indication of the actual engine coolant temperature. Otherwise, perform the CTS RESISTANCE TEST.

CTS Resistance Test

1. Disconnect the CTS connector.
2. Test the resistance of the sensor as per following tables.

CTS		READING
Wires color		Refer to CTS TEMPERATURE SENSOR TABLE
Green	Green/Black	

CTS TEMPERATURE SENSOR TABLE		
TEMPERATURE °C	RESISTANCE Ω	
	LOW	HIGH
- 40	47423	56157
- 10	8260	10,560
0	5423.5	6119.8
20	228	2720
80	290	350
100	170	210

NOTE: To test sensor at various temperatures, remove sensor and use a heat gun, ice and a thermometer.

If resistance is out of specification, replace the CTS. If resistance test is good, proceed with the following steps.

3. Reconnect the CTS connector.
4. Remove parts required to access ECU connectors, refer to ECU CONNECTOR ACCESS in this subsection.

7. Recheck resistance from the ECU connector as per following table.

ECU		READING
PIN		Refer to CTS TEMPERATURE SENSOR TABLE
Pin2(Black)	Pin 10 (Green)	

If resistance value is correct, refer to ECU REPLACEMENT.

If resistance value is incorrect, repair the connectors or replace the wiring harness between ECU connector and the CTS.

CTS Replacement

1. Drain coolant, refer to PERIODIC MAINTNENANCE PROCEDURES subsection.

2. Cut locking ties of wiring harnesses and move wiring aside for access.

NOTE: Take note of wiring and locking tie position before removal.

3. Disconnect CTS connector.

4. Remove CTS from engine.

5. Install new CTS and torque as specified.

CTS	
Tightening torque	16 Nm ± 2 Nm (142 lbf.in±18 lbf.in)

6. Reinstall remaining removed parts.

NOTE: Ensure to re install wiring harness as noted prior to removal.

7. Refill and bleed the cooling system, refer to PERIODIC MAINTNENANCE PROCEDURES subsection.

6. DRIVE TRAIN

FRONT DRIVE.....	6-1	REAR DRIVE.....	6-3
TIRES AND WHEELS.....	6-4		

6.1 FRONT DRIVE

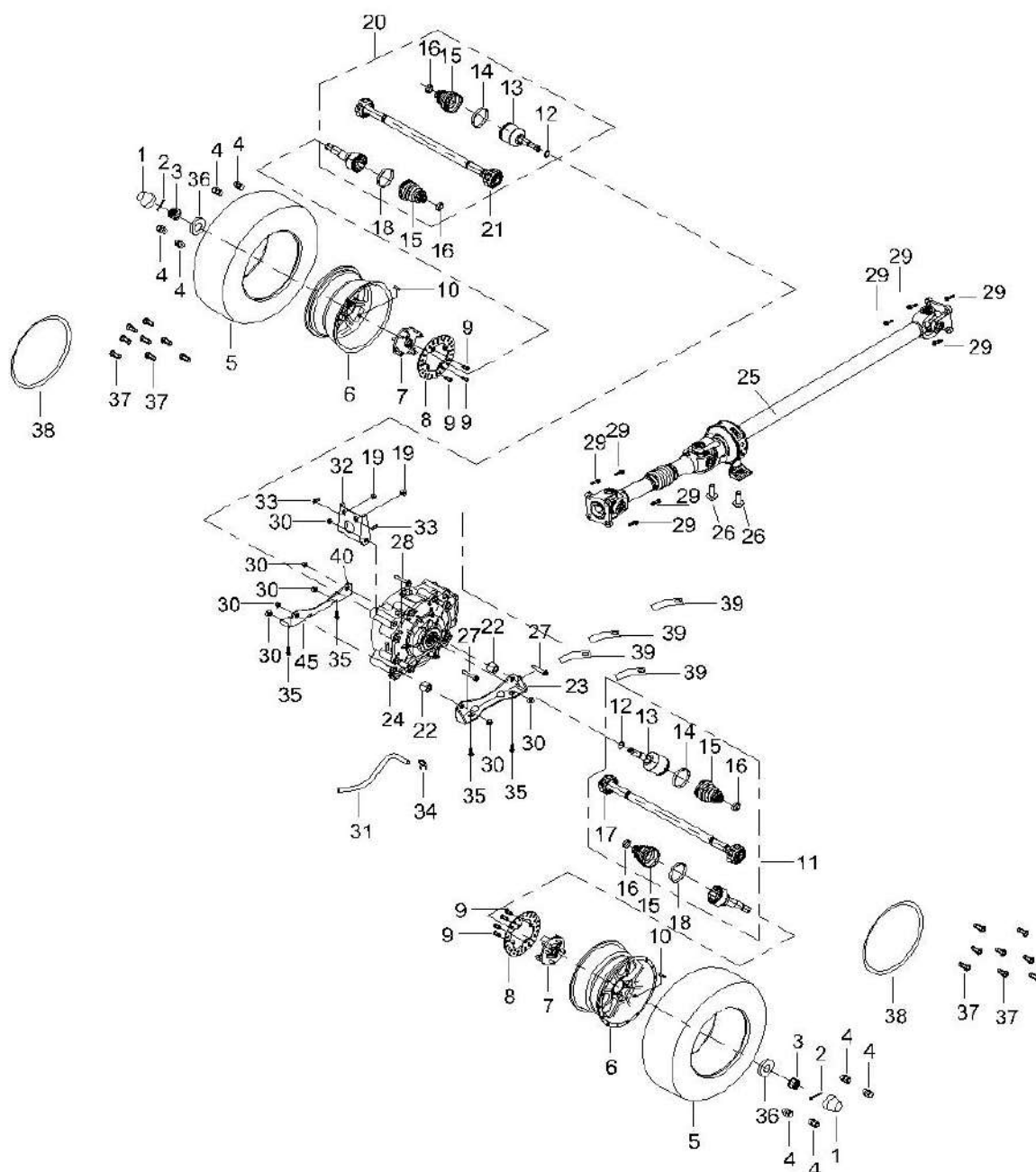

Names of components:

1. Wheel Dust-Proof Cover	2. Cotter Pin	3. M22 Nut	4. M12 Nut	5. Front Tire
6. Front Rim	7. Front Wheel-Hub	8. Front Brake Disc	9. M8 Bolt	10. Air Valve
11. Front C.V. Shaf	12. Snap Roll	13. Universal Joint	14. Hose Clamp	15. Dust Cover
16. Hose Clamp	17. Intermediate Shaft	18. Hose Clamp	19. M8 Nut	20. Front C.V. Shaft
21. Intermediate Shaft	22. Steering Gear Bushing	23. Front Axle Lower Mounting Plate	24. Front Differential	25. Front drive shaft
26. M12 Bolt	27. M10 Bolt	28. M10 Bolt	29. M10 Bolt	30. M10 Nut
31. Vent Pipe	32. Upper Mounting Plate	33. M8 Bolt	34. Clip	35. M10 Bolt
36. Washer	37. M8 Bolt	38. Anti-Escape Ring	39. Buckle	40. Front Axle Lower Mounting Plate

GENERAL

The procedure explains how is the same for the RH and LH side unless otherwise instructed.

Clean thread before applying a thread locker.

⚠WARNING

Torque wrench tightening specifications must be strictly adhered to.

Locking devices must be replaced with new ones when removed (e.g.: locking tabs, elastic stop nuts, self-locking fasteners, cotter pins, etc.).

PROCEDURES**Front Wheel-hub****Removal**

Place the vehicle at the parking rack position and lift the front of the vehicle with a jack.

Remove front wheel.

Remove the castle nuts, cotter pins and other standard parts.

Remove two screws and brake oil pipe clip, separating front brake oil pipe on upper A-Arm. Remove the two M10 installing bolts of the left brake caliper and remove the caliper from the disc brake disc.

NOTE: During dismantling, brake action is prohibited to be conducted, avoiding brake friction plate close or placing spacer between friction plates to avoid friction plate close and to facilitate future installation.

Pull the wheel-hub to remove it.

Inspection

Check wheel-hub for cracks or other damages.

Check the splines in the front wheel-hub for wear or other damages. If so, please replace it.

If any damages are detected on wheel hub, replace it with a new one.

Check wear ring. If damage is apparent, replace the wear ring.

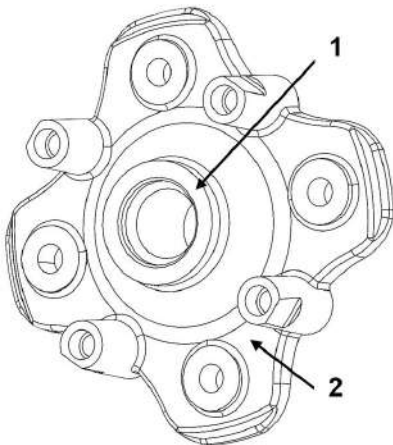

1. Wear ring
2. Wheel hub

Installation

The installation is the reverse of removal procedure. Install washer so that the inside diameter protrudes outward and contacts the nut.

Tighten the castle nut M20 on the drive shaft end to 280~300N.m and further tighten until one of its grooves is aligned with a cotter pin hole. Install a

new cotter pin and the wheel cap. Fold one pin of cotter pin over drive shaft end.

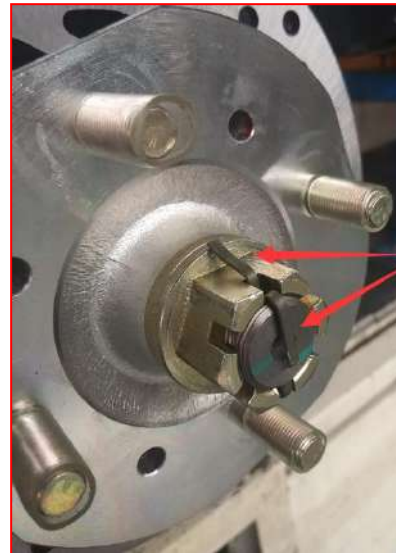
**Front half shaft****Removal**

Remove the appropriate wheel hub.

Remove the guard plate of brake caliper.

Remove the fixing clip of brake hose on the knuckle.

Remove the shock absorber.

Remove the ball joint of tie rod from the steering knuckle.

Remove the nuts of knuckle upper and lower ball joint.

Remove the knuckle.

Pull drive shaft out of front differential.

Inspection

Inspect the dust-proof sleeves. If there is any damage or evidence of leaking lubricant, replace them.

Check the outer splines of the half shafts for damage, cracks, etc. Check whether the dust-proof sleeves are pulverized, cracked, etc. If any, please replace them in time. Remove clamp for dust-proof sleeve, then remove universal joint of differential side. Remove and replace the dust-proof sleeve from the differential side of drive shaft.

Check if the bearing in knuckle moves freely and smoothly. If not, replace them.

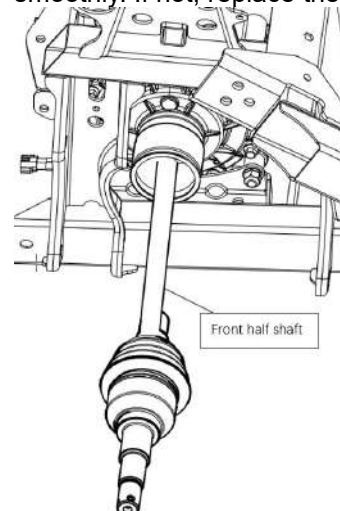
**Installation**

Apply grease to the splines and insert the end of

drive shaft in differential and pull joint a little to make sure that the stop ring is locked in differential side gear groove.

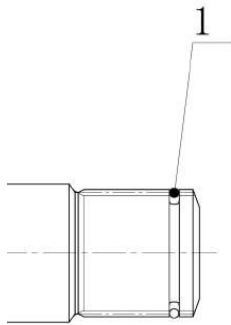

1. Stop ring

The ring should be close to the differential. Insert the other end of drive shaft in the knuckle and install the knuckle to the lower suspension arm. Install and torque the ball joint retaining bolts to 45N.m

Install all other removed parts.

Front Differential

Removal

Clean the drain plug area. Place an oil pan under the front reducer case, and then drain oil completely by removing the drain plug.



Remove front wheels.
Remove the front half shaft.
Loosen M8 bolts, then separate front drive shaft and front differential.

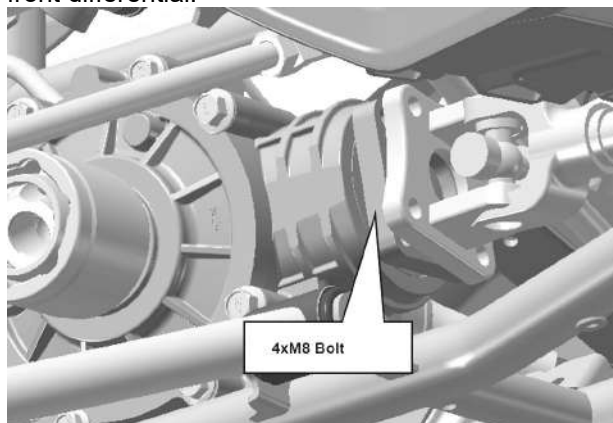

Remove the front differential mounting bolts, then remove front differential from frame. Disconnect the 2WD/4WD motor wires. Remove the front differential out of frame from left side.

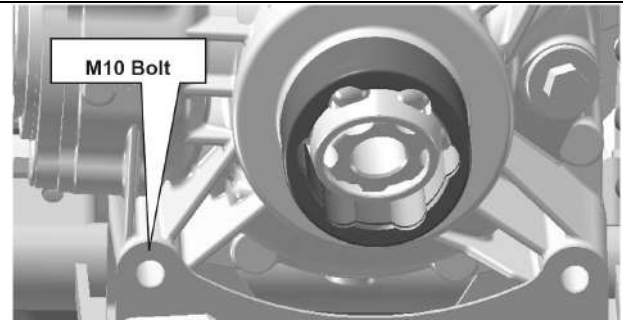

Disassembly

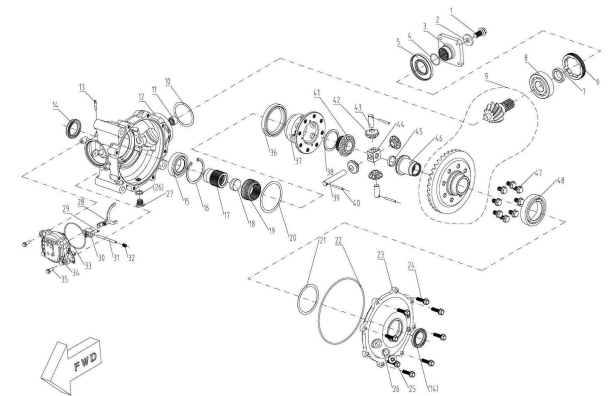

Unscrew M8 bolts, then separate half housing.
NOTE: Be careful to keep the spacer shim on the each side of differential case.
-Extract differential case with driven bevel gear out of half housing.
-Unscrew M10 bolts, then separate driven bevel gear from differential case.
-Unscrew M8 bolts, then remove driving bevel gear from half differential housing.
--Unscrew M6 bolts, remove 2WD/4WD motor from half differential housing. Then remove shifting fork shaft, shifting fork, spline housing.

Inspection

Check the gear box, cover, bearing, oil seal and dust seal for wear or damage. If any damage or wear is found, replace with a new oil seal or dust seal.

Check the internal spline meshing with the half shaft for damage, cracks, etc. If so, please replace it with a new one.

Installation

The installation is the reverse of the removal procedure. Pay attention to refill the oil. Refer to specifications.

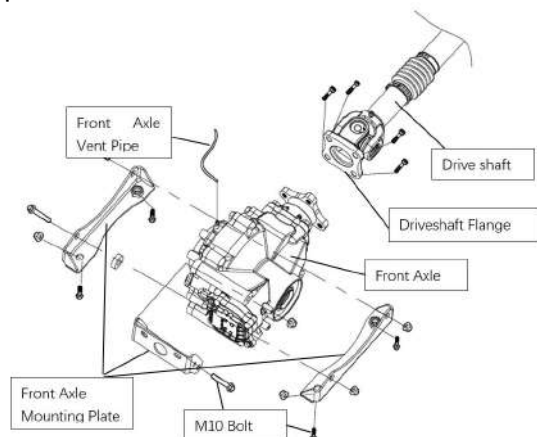

Front drive shaft

Remove the front transmission shaft shield and seat bottom guard plate, then remove the connecting bolts of the engine and front drive shaft front axle and front drive shaft respectively, and take them out from the side of the frame.

Check the drive shaft for wear or damage. If any defects are found, replace them with new drive shafts.

Check if the U-shaped joint moves freely in all directions.

Check the bellows for holes or brittleness.

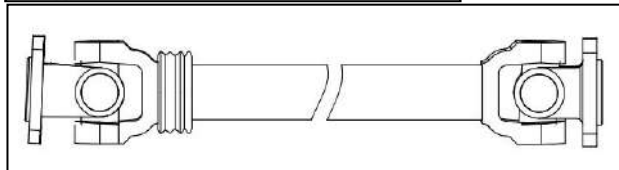
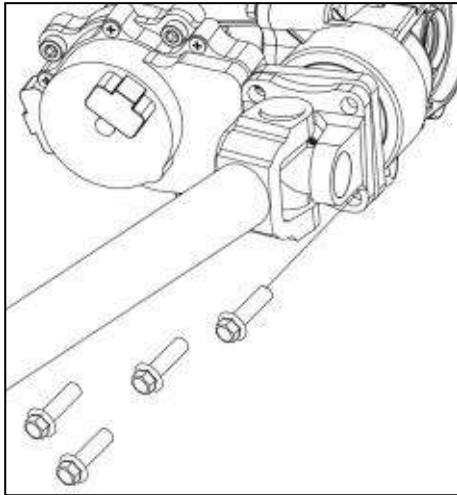
**Installation**

The installation is the reverse of the removal procedure.

Ensure tighten the bolts to specified torque.

Installation location	Specifications (mm)	Torque Nm.(Ft.lbs)
Mounting nut of wheel rim	M10	60(44)
Nut of wheel hub	M22	300(220.6)
Fastening nut of front differential	M10	80(58.8)
Bolt of front propeller shaft flange	M10	80(58.8)

Front Drive Shaft U-joint**Removal**

Remove internal snap ring from bearing caps.

Support inner yoke in vice and drive other yoke down with a soft hammer.

Support U-joint in vice and drive inner yoke down to remove remaining bearing caps.

Remove U-joint cross.

Installation

Install new U-joint cross in inner yoke.

Install new bearing cap by hand.

NOTE: Carefully install U-joint cross with grease fitting properly positioned.

Tighten vise to force bearing caps in.

Using a suitable tappet, fully seat bearing cap in one side. Continually, check for free movement of bearing cross as bearing caps are assembled.

Install snap ring.

Repeat procedure for other sides.

Grease U-joint, using a grease gun with synthetic grease.

6.2 REAR DRIVE

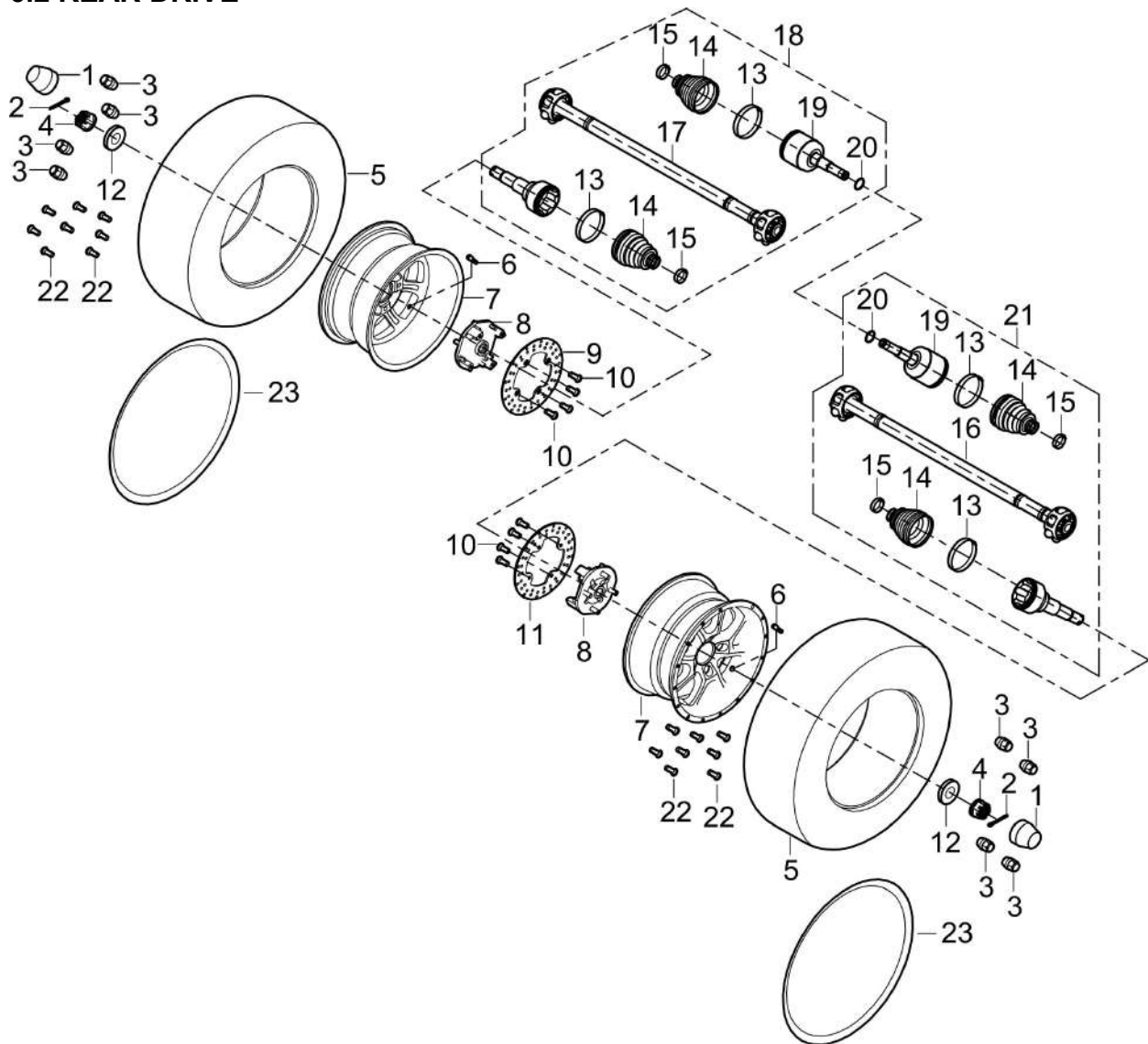

1. Wheel Dust-Proof Cover	2. Cotter Pin	3. M12 Nut	4. M22 Nut	5. Rear Tire
6. Air Valve	7. Rear Rim	8. Rear Wheel-Hub	9. Rear Brake Disc	10. M8 Bolt
11. Rear Brake Disc	12. Washer	13. Hose Clamp	14. Dust-Proof Sleeve	15. Hose Clamp
16. Intermediate Shaft	17. Intermediate Shaft	18. Rear Half Shaft	19. Universal Joint	20. Snap Roll
21. Rear Half Shaft	22. M8 Bolt	23. Anti-Escape Ring		

Rear wheel-hub**Removal**

Loosen wheel nut of the appropriate.

Install a jack stand under the frame to lift the rear of vehicle off the ground until the shock absorber is fully extended.

Remove the rear wheel.

Remove cotter pin, castellated nut and washer.

Remove a screw and brake oil pipe clip, separating brake oil pipe on upper A-Arm. Remove the two M10 installing bolts of the left brake caliper and remove the caliper from the disc brake disc.

NOTE: During dismantling, brake action is prohibited to be conducted, avoiding brake friction plate close or placing spacer between friction plates to avoid friction plate close and to facilitate future installation.

Remove the caliper from knuckle.

Pull the wheel hub to remove it.

Inspection

Check wheel-hub for cracks or other damages. If any damage is detected on wheel hub, replace it with a new one.

Check inner splines in the front wheel-hub for wear or other damages. If so, please replace it.



Check wear ring. If damage is apparent, replace the wheel-hub.

Installation

The installation is the reverse of removal procedure. Install washer so that the inside diameter protrudes outward and contacts the nut.

Tighten the castle nut on the drive shaft end to 280~300N.m and further tighten until one of its grooves is aligned with a cotter pin hole. Install a new cotter pin and the wheel cap. Fold one pin of cotter pin over drive shaft end.

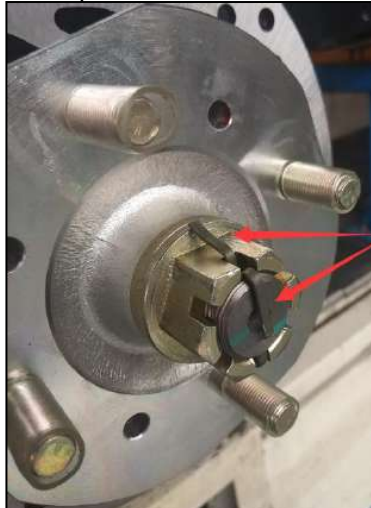
**Rear half shaft****Removal**

Remove the appropriate wheel hub.

Remove the fixing clip of brake hose on the upper A-Arm.

Remove the brake caliper.

Remove the shock absorber.

Remove the ball joint of rear stabilizer bar from the steering knuckle.

Remove the nuts between steering knuckle with upper and lower A-Arm.

Remove the knuckle.

Pull drive shaft out of rear differential.

Inspection

Check the outer splines of the half shafts for damage, cracks, etc.

Check whether the dust-proof sleeves are pulverized, cracked, etc. If any, please replace them in time. Remove clamp for dust-proof sleeve, then remove universal joint of differential side. Remove and replace the dust-proof sleeve from the differential side of drive shaft.

Check if the bearing in knuckle moves freely and smoothly. If not, replace them.

Installation

Apply grease to the splines and insert the end of drive shaft in differential and pull joint a little to make sure that the stop ring is locked in differential side gear groove.

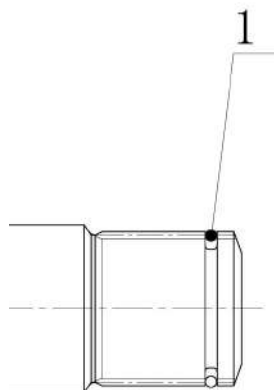
**1. Stop ring**

Insert the other end of drive shaft in the knuckle and install the knuckle to the lower suspension arm. Install and torque the ball joint retaining bolts to 45N.m

Install all other removed parts.

Ensure tighten the bolts to the specified torque.

Installation location	Specifications (mm)	Torque N.m(kgf.m)
Mounting nut of wheel rim	M10	60(6.1)
Nut of wheel hub	M22	300(30.6)
Bolt of PARK brake caliper	M10	80(8.2)

6.3 TIRES AND WHEELS

Tire thread

When the tire groove decreases to 3 mm (0.12 in) due to wear, replace the tire.

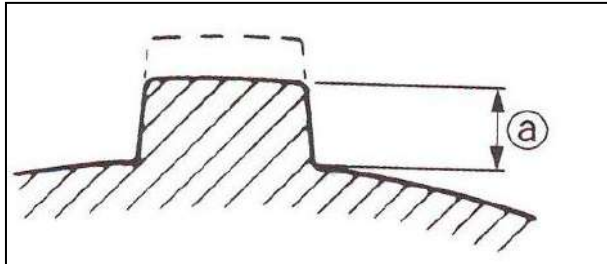

When the tires are replaced, never install a bias tire with a radial tire. Such a combination could create handling and/or stability problems.

Do not mix tires of different size and/or design on the same axle.

Front and rear tire pairs must be the identical model and manufacturer.

For unidirectional tread pattern, ensure that the tires are installed in the correct direction of rotation.

The radial tires must be installed as a complete set. In dismantling tires, use special crowbar and rim protection device.

Tire replacement

Use jack to support vehicle and ensure its no dropping.

Remove the wheels.

After removing the air valve cap, release the tire pressure by depressing the valve.

Dismount the bead from the rim completely.

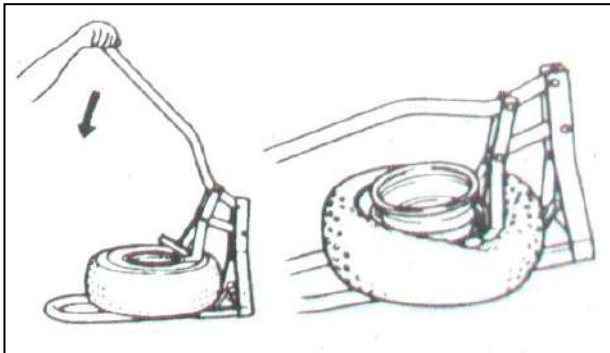

Separate the tire from the rim by using a set of tire levers and rim protectors.

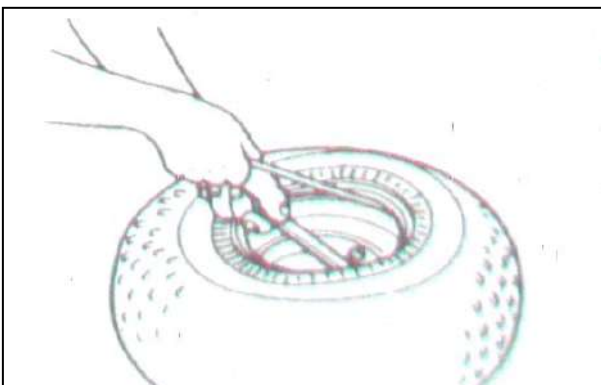

CAUTION: When using the tire lever, do not scratch or hit the sealing portion of the wheel or it may cause air leakage.

Apply tire lubricant to the new tire bead and the flange of the rim. But never apply grease, oil or gasoline to the tire bead because they will

deteriorate the tire.

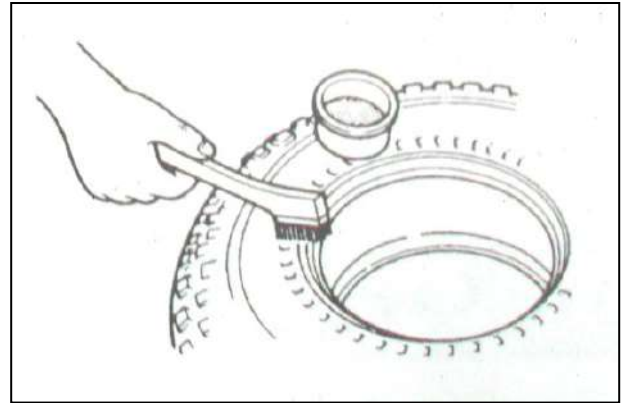

CAUTION: The standard tire fitted on this vehicle is AT27x9-14 for the front and AT27x11-14 for the rear. The use of tires other than the standard may cause instability. It is highly recommended to use the specified tire.

Inspect the sealing portion of the rim for contamination and distortion before installing the tire on the rim.

Mount the new tire on the rim.

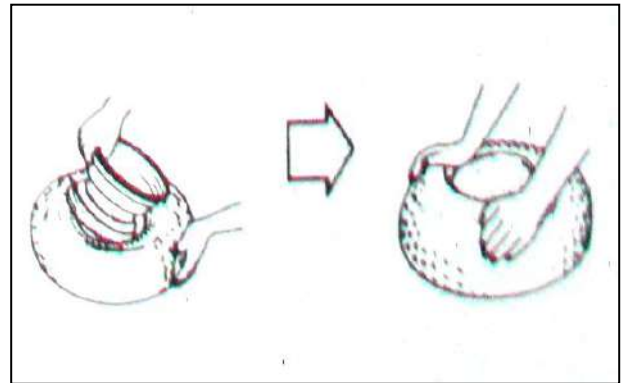

CAUTION: When installing each tire, make sure the arrow on the tire points in the direction of rotation. Also make sure the outer side of the wheel rim is facing outward.

Inflate the tire to seat the tire bead.

Check the rim line cast on the tire side walls. It must be equidistant from the wheel rim all the way around. If the distance between the rim line and the wheel rim varies this indicates that the bead is not properly seated. If this is so, deflate the tire completely, and unseat the tire bead on both sides. Then coat the bead with clean water and re-seat the tire.

Adjust the tire pressure to specification.

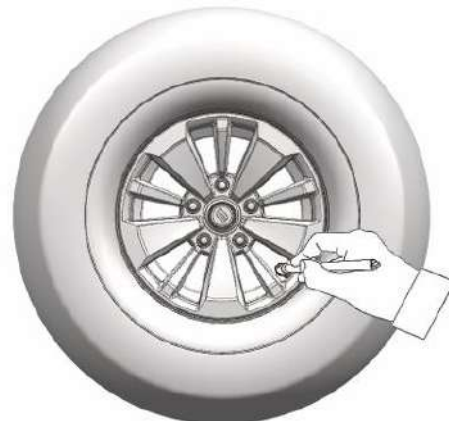

7. STEERING SYSTEM

TIE ROD.....	7-2	REDIRECTOR.....	7-2
STEERING ALIGNMENT.....	7-2		

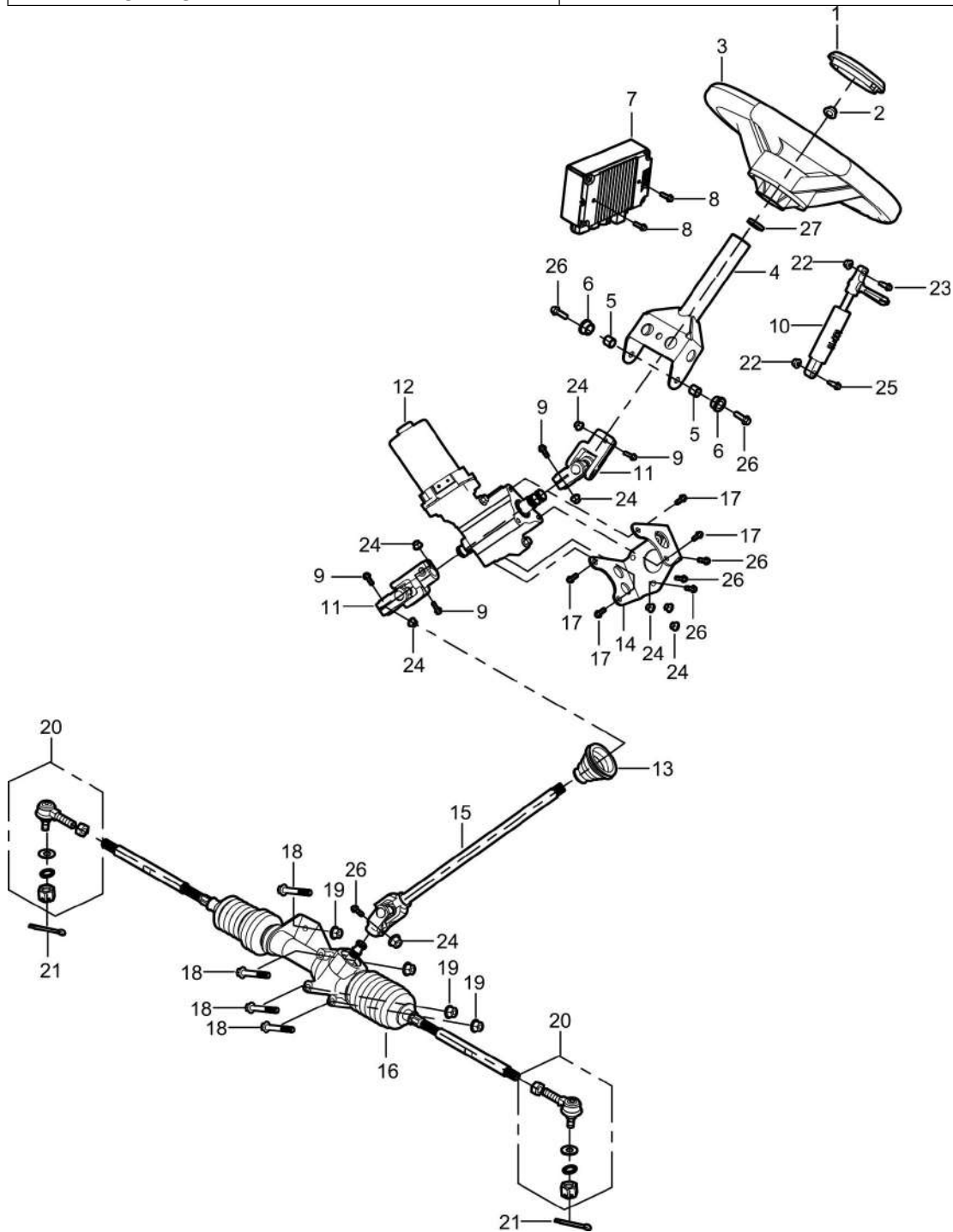

1. Steering Wheel Center Cap	2. M12 Nut	3. Steering Wheel	4. Steering Column	5. Steering Inner Bush
6. Steering Nylon Sleeve	7. EPS Controller	8. M6 Bolt	9. M8 Bolt	10. Steering Column Gas Spring
11. Universal Joint	12. EPS	13. Tie Rod Bellows	14. EPS Mounting Plate	15. Tie Rod
16. Redirector	17. M8 Bolt	18. M10 Bolt	19. M10 Nut	20. Tie rod ball joint
21. Cotter Pin	22. M6 Nut	23. M6 Nut	24. M8 Nut	25. M8 Bolt
26. M8 Bolt	27. Steering Column Bushing			

7.1 TIE ROD

Removal

Remove the M8 bolt, nut and universal joint.
 Remove front wheel, wheel-hub, brake disc.
 Remove castle nut, cotter pin and the knuckle.
 Remove ball joint and tie rod.

Inspection

Inspect the tie rod for distortion or damage. If any damage is found, replace the tie rod with a new one.
 Inspect the tie ends for smooth movement. If there are any abnormalities, replace the tie rod end with a new one.

Inspect the tie rod end boot for wear or damage. If any damage is found, replace the tie rod end with a new one.

Tie rod installation

1. For the installation, reverse the removal procedure.
2. Tighten tie rod lock nuts finger tight.
3. Install tie rod on steering knuckle.
4. Torque tie rod castle nut to 78-104Nm.
5. Install new cotter pins. Both ends of cotter pins must be folded around nut.

7.2 STEERING ALIGNMENT

Park vehicle on flat ground, make sure the tire pressure for right and left tires is same and set to the proper specification, set the front wheels in the straight position, then place a load of 75kg on the seat.

Steering wheel looseness check

Move the steering wheel as shown in the figure, check the steering column bearing wear, steering shaft reverse joint clearance, loose steering wheel and loose steering column. Replace or repair if necessary.

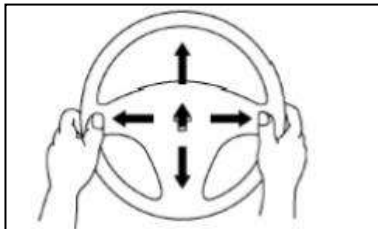

Steering wheel clearance check

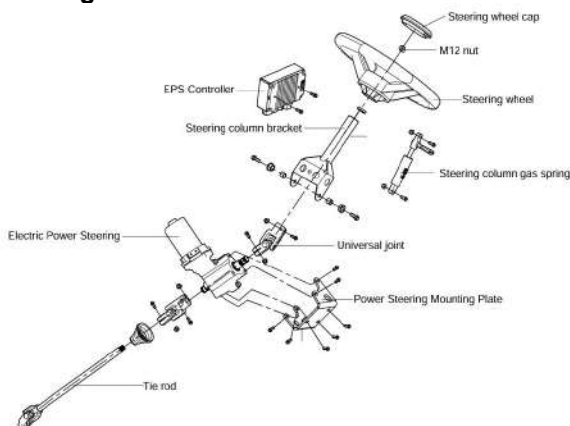

At the position directly in front of the steering wheel, lightly turn the steering wheel to the left and right to adjust the clearance to within the specification. If the clearance exceeds the specified range, whether the steering shaft universal joint is worn or the steering

gear clearance is too large, it should be corrected.

Steering assist check

Check whether the EPS is damaged. If the damage is serious, replace the new steering assist according to the actual situation.

Check whether the steering assist click is working normally under the working state of the engine. If the required steering force is too large or there is a stuck phenomenon, repair or replace it according to the situation.

Steering Alignment Check

Measure the distance A and B of the front wheels and calculate the difference.

Toe-in.: $B - A \leq 5\text{mm}$

A: front of front wheel

B: rear of front wheel

Out of range of toe-in: → Adjust nut of tie rod

CAUTION: After adjusting toe-in, first rotate steering wheel from center position to the left and right completely, to ensure that is the same corner, then slowly run vehicle to see whether its direction can be controlled.

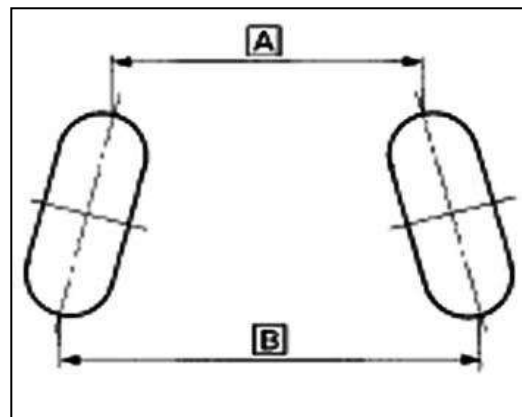

8. SUSPENSION SYSTEM

FRONT SUSPENSION.....	8-1	REAR SUSPENSION.....	8-5
-----------------------	-----	----------------------	-----

8.1 FRONT SUSPENSION

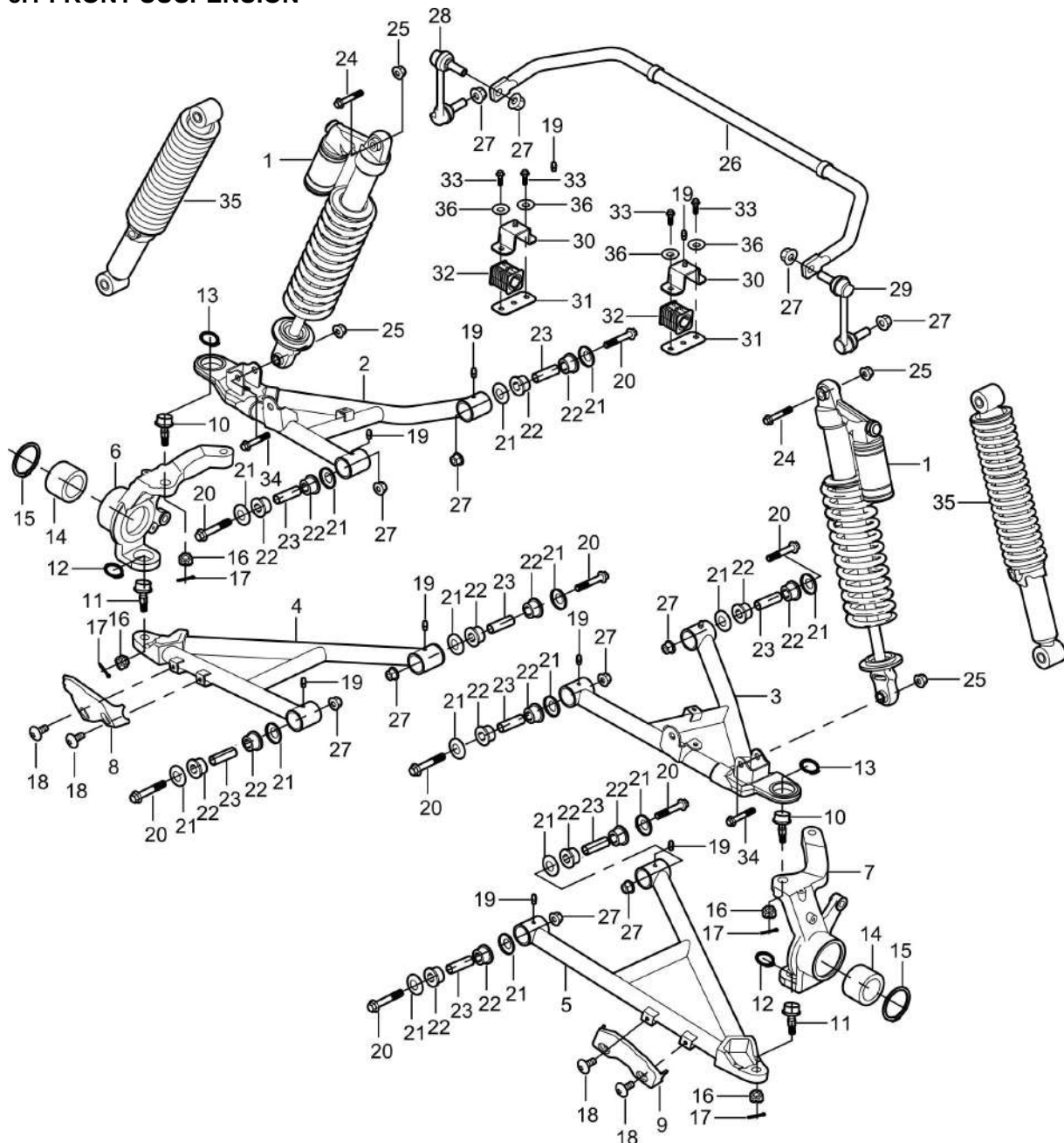

1. Front Airbag Shock Absorber	2. RH Upper Front Suspension Arm	3. LH Upper Front Suspension Arm	4. RH Lower Front Suspension Arm
5. LH Lower Front Suspension Arm	6. RH Lower Suspension Arm	7. RH Steering Knuckle	8. LH Front Arm Guard
9. RH Front Arm Guard	10. Ball Joint	11. Ball Joint	12. Snap Ring
13. Snap Ring	14. Bearing	15. Retaining Rings	16. M12 Castle Nut
17. Cotter Pin	18. M6 Bolt Screw	19. Grease Zerk	20. M12 Bolt
21. Nylon Sleeve Cover	22. Nylon Sleeve	23. Inner Sleeve	24. M10 Bolt
25. M10 Nut	26. Front Stabilizer Bar	27. M12 Locking	28. Sway Bar Pull Rod
29. Sway Bar Pull Rod	30. Clamp	31. Support Plate	32. Cushion
33. M8 Bolt	34. M10 Bolt	35. Front Regular Shock Absorber	36. Washer

GENERAL

The procedure explains how is the same for the RH and LH side unless otherwise instructed.

Clean thread before applying a thread locker.

⚠ WARNING

Torque wrench tightening specifications must be strictly adhered to.

Locking devices must be replaced with new ones when removed (e. g.: locking tabs, elastic stop nuts, self-locking fasteners, cotter pins, etc.).

PROCEDURES

TIRES AND WHEELS

⚠ WARNING

When the tires are replaced, never install a bias tire with a radial tire. Such a combination could create handling and/ or stability problems.

Do not mix tires of different size and/ or design on the same axle.

Front and rear tire pairs must be the identical model and manufacturer.

For unidirectional tread pattern, ensure that the tires are installed in the correct direction of rotation.

The radial tires must be installed as a complete set.

Severe injury or death can result if these instructions are not followed.

The tires are directional and their rotation must be kept in a specific direction for proper operation.

SHOCK ABSORBER

Removal

Loosen nut of the appropriate wheel.

Install a jack stand under the frame to lift the front of vehicle off the ground until shock absorber is fully extended then.

Loosen wheels and M10 bolts and nuts.

Remove front shock absorber from vehicle.

Disassembly

1. Secure the *SPRING COMPRESSOR* in a vise.

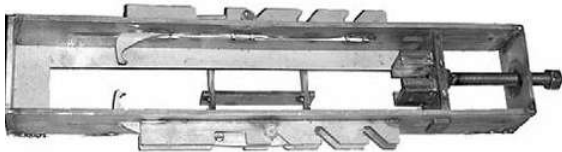

Spring compressor

2. Position the shock absorber in the tool and install the spring compressor hooks.

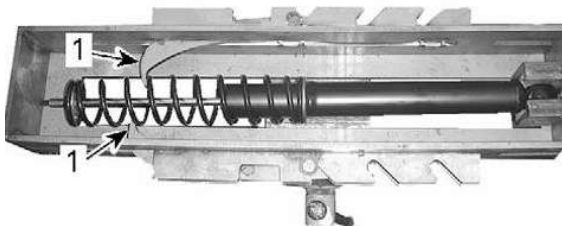

1. Spring compressor hooks

3. Tighten the spring compressor tool screw until the spring is sufficiently compressed to remove spring stopper.

4. Release the spring compressor tool screw.

5. Remove spring from shock absorber.

Inspection

Inspect spring for apparent damage, any defect such as scratches or rust can affect the spring durability.

When the adjustment is at the lowest preload, ensure that adjustment cam and spring stopper are not loose. They must be under spring pressure. Otherwise, the spring stopper might fall off.

Inspect the shock absorber for oil leakage or damage, inspect the bushing for wear or damage. If any damage is found, replace the front shock absorber with a new one.

Extend and compress the piston several times over its entire stroke. Check that it moves smoothly and with uniform resistance with rod up. Any of the following conditions will denote a defective shock:

-A skip or hang up when reversing stroke at mid-travel.

-Seizing or binding conditions except at extreme end of either stroke.

-A gurgling noise after completing one full compression and extension stroke.

Replace shock if any these conditions are found.

Assembly and Installation

For assembly and installation, reverse the disassembly and removal process.

LOWER SUSPENSION ARM PROTECTOR

Removal

Remove M6 screws then remove front C.V. shaft cover.

Inspection

Check cover for cracks or damages. Replace if necessary.

Installation

For installation, reverse the removal process.

Tighten M6 screws for cover to 9~12Nm.

STEERING KNUCKLE

Removal

Place the vehicle on jack stands and remove the appropriate wheel.

Remove wheel hub.

Remove the cotter pin (discard it) and M10 castle nut, separate the tie rod from steering knuckle.

Remove the cotter pin and unscrew the upper castle nut(M12), separate the upper ball joint from steering knuckle.

Using a hammer, hit on the knuckle tip to separate ball joint from knuckle. A ball joint remover can be used if the ball joint is jammed into knuckle.

CAUTION: Never hit on upper suspension arm. Permanent damages could be caused to arm and its replacement would be necessary.

Remove the cotter pin and unscrew the lower castle nut(M12), separate the lower ball joint from steering knuckle.

Remove steering knuckle.

Remove retaining ring.

Using bearing extractor to disassembly the bearing.

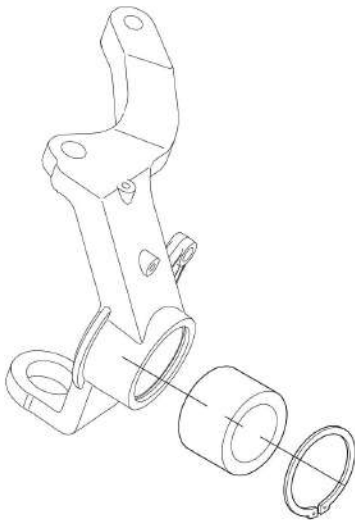

Inspection

Inspect the knuckle for damage. If any damages are found, replace the knuckle with a new one.

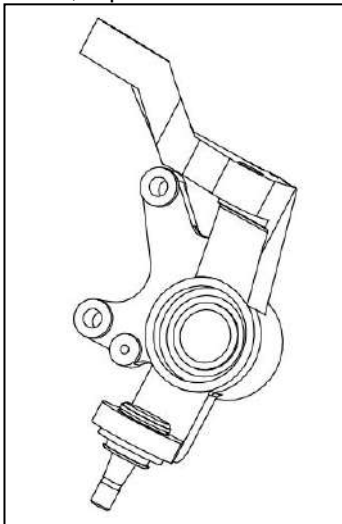

Check ball joint for damage, pitting, looseness and roughness. If so, replace it.
 Check ball joint bellows for cracks. Change if necessary.
 Check bearing and ring for damage or wear, If any damages or wear are found, replace a new one.
 Rotate the inner race by hand to inspect for abnormal noise and smooth rotation.

STABILIZER BAR

Removal

Remove M12 nuts, then separate the ball joint and front upper suspension arm.

Remove M12 nuts, then remove ball joint from stabilizer bar.

Remove four M8 bolts and clamps, then remove stabilizer bar from frame.

Inspection

Check whether the lining of the stabilizer is powdered or cracked. If so, please replace it with a new lining.

Check the cushion for cracked or damaged. If so, please replace it with a new one.

Check the stabilizer ball joint for damage, pitting, looseness, etc., and check the ball bellows for cracks, damage, powdering, etc. If so, please replace it with a new one.

Installation

For installation, reverse the removal process.

Use suspension grease to lubricate sway bar. There are two grease zerk on sway bar.

LOWER SUSPENSION ARM

Lubrication

Use suspension grease to lubricate both suspension arm. There are two grease zerk on each arm.

Inspection

Inspect the suspension arm and for damage or distortion. If any damages or distortion are found, replace the suspension arm with a new one.

Move suspension arm from side to side. There should be no noticeable loose. Replace bushing if necessary.

Move suspension arm up and down. There should be no noticeable loose. Replace bushing if necessary.

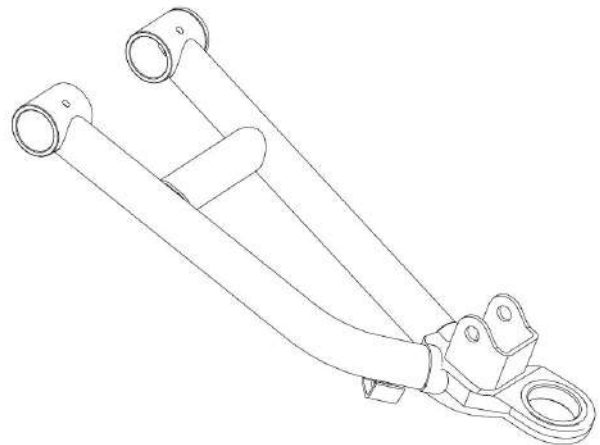

Inspect the bushing and Nylon sleeve for wearing or damaged. Replace if necessary.

Check ball joint bellows on lower suspension arm for crack or damaged. Ensure it's moving freely. Replace ball joints as required, see blew for procedure.

Removal

Remove wheel.

Remove the cotter pin and castle nut M12, separate the lower suspension arm from steering knuckle.

Remove the M12 bolts and nuts, separate the lower suspension arm from frame.

Remove the lower suspension arm from frame.

Installation

For installation, reverse the removal process.

LOWER BALL JOINT

Inspection

Check ball joint bellows for crack or damaged. Replace as required, Check ball joint for damage, pitting, looseness or roughness. If so, replace it.

Removal

Remove knuckle from vehicle.

Remove the snap ring.

Using a press and a small piece of pipe, extract the ball joint. Support the knuckle properly to avoid damaging ball joint location.

Installation

For installation, reverse the removal process.

To install the ball joint properly, use the ball joint installer.

Support the knuckle before pressing the ball joint into its location.

Reinstall the snap ring. If it seems loose, replace it with a new one.

UPPER SUSPENSION ARM

Lubrication

Use suspension grease to lubricate both suspension arm. There are two grease zerk on each arm.

Inspection

Inspect the suspension arm and for damage or distortion. If any damages or distortion are found, replace the suspension arm with a new one.

Move suspension arm from side to side. There should be no noticeable loose. Replace bushing if necessary.

Move suspension arm up and down. There should be no noticeable loose. Replace bushing if necessary.

Check ball joint for damage, pitting, looseness and roughness. If so, replace it.

Check ball joint bellows for cracks. Change if

necessary.

Removal

Remove wheel.

Remove two screws and brake oil pipe clip, separating front brake oil pipe on upper A-Arm.

Remove the front shock absorber.

Remove M12 nuts, then separate the ball joint and front upper suspension arm.

Remove the cotter pin and M12 castle nut.

Using a hammer, hit on the knuckle tip to separate to separate the ball joint from steering knuckle.

CAUTION: Never hit on upper suspension arm. Permanent damages could be caused on arm and its replacement will be necessary.

Remove the M10 bolt and nut, separate the upper suspension arm from frame.

Remove the upper suspension arm from frame.

Installation

For installation, reverse the removal process.

Tightening M10 nut : 45~59Nm.

Tightening M12 castle nut :78~104Nm.

UPPER BALL JOINT

Inspection

Check ball joint bellows for crack or damaged. Replace as required,

Check ball joint for damage, pitting, looseness or roughness. If so, replace it.

Removal

Remove upper suspension arm from vehicle.

Remove the snap ring.

Using a press and a small piece of pipe, extract the ball joint. Support the upper suspension arm properly to avoid damaging ball joint location.

Installation

For installation, reverse the removal process.

To install the ball joint properly, use the ball joint installer.

Support the upper suspension arm before pressing the ball joint into its location.

Reinstall the snap ring. If it seems loose, replace it with a new one.

Install the upper suspension arm.

8.2 REAR SUSPENSION

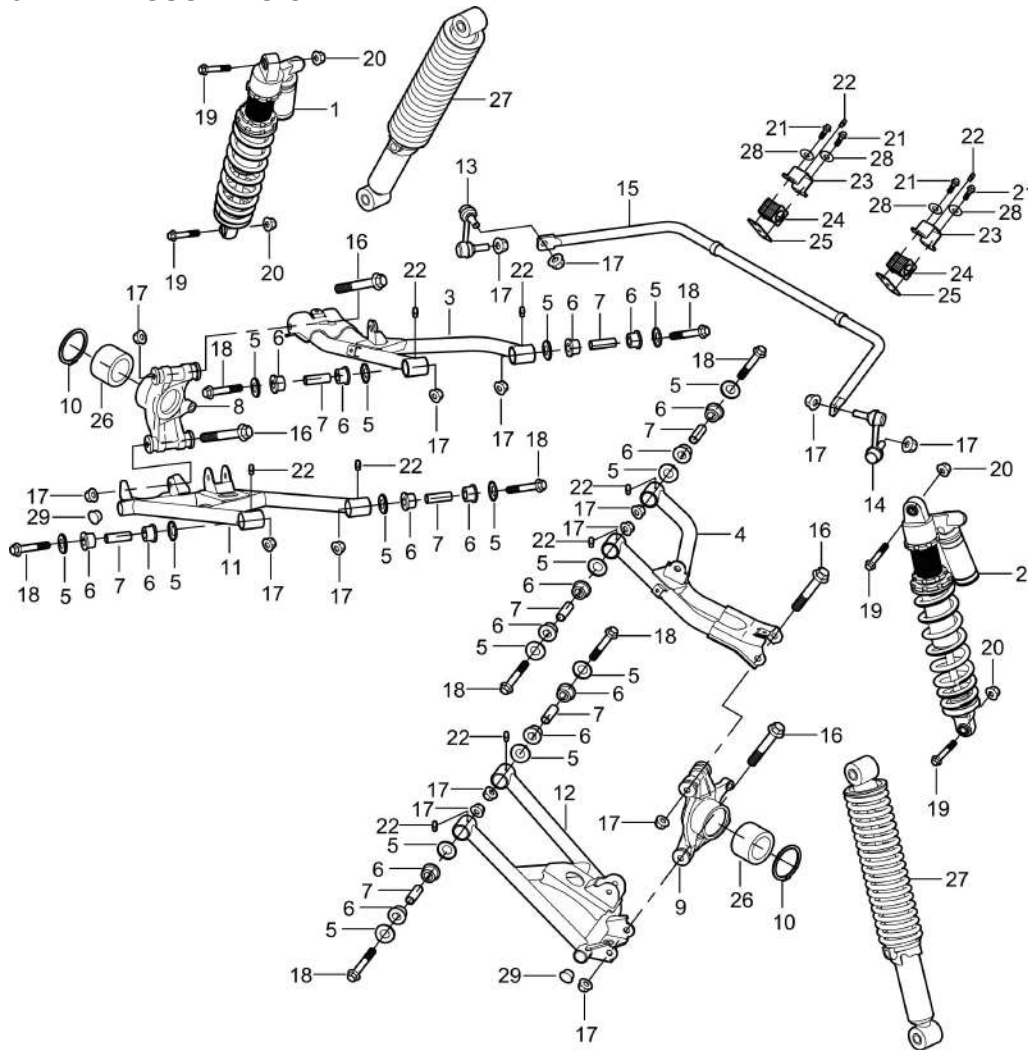

1.RH Rear Airbag Shock Absorber	2. RH Rear Airbag Shock Absorber	3. RH Upper Rear Suspension Arm	4. LH Upper Rear Suspension Arm
5. Arm Nylon Sleeve Cover	6. Arm Nylon Sleeve	7. Arm Inner Sleeve	8.LH Knuckle
9. RH Knuckle	10. Retaining Rings for Bores	11. RH Lower Rear Suspension Arm	12.LH Lower Rear Suspension Arm
13. RH Sway Bar Pull Rod	14. LH Sway Bar Pull Rod	15. Rear Stabilizer Bar	16. M12 Bolt
17. M12 Nut	18. M12 Bolt	19. M10 Bolt	20. M10 Nut
21. M8 Bolt	22. Grease Zerk	23. Clamp	24.Cushion
25. Support Plate	26.Bearing	27. Basic Rear Shock Absorber	28.Washer
29. Swing Arm Plug			

GENERAL

The procedure explains how is the same for the RH and LH side unless otherwise instructed.
Clean thread before applying a thread locker.

⚠ WARNING

Torque wrench tightening specifications must be strictly adhered to.
Locking devices must be replaced with new ones when removed (e. g.: locking tabs, elastic stop nuts, self-locking fasteners, cotter pins, etc.).

PROCEDURES

TIRES AND WHEELS

⚠ WARNING

When the tires are replaced, never install a bias tire with a radial tire. Such a combination could create handling and/ or stability problems.
Do not mix tires of different size and/ or design on the same axle.
Front and rear tire pairs must be the identical model and manufacturer.
For unidirectional tread pattern, ensure that the tires are installed in the correct direction of rotation.
The radial tires must be installed as a complete set.
Severe injury or death can result if these instructions are not followed.

The tires are directional and their rotation must be kept in a specific direction for proper operation.

During assembly or installation, use the torque values and service products as in the torque table.

SHOCK ABSORBER

Removal

Loosen wheel nut.

Lift rear of vehicle until rear shock absorber is fully extended then install a jack stand under the frame to support the vehicle off the ground.

Remove:

-Rear wheel

-M10 bolt and nuts

Remove rear shock absorber from vehicle.

Disassembly

1. Secure the *SPRING COMPRESSOR* in a vise.

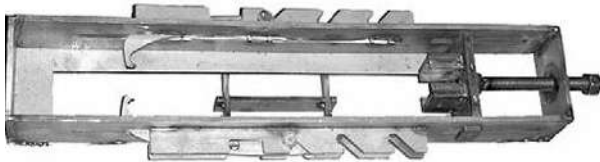

Spring compressor

2. Position the shock absorber in the tool and install the spring compressor hooks.

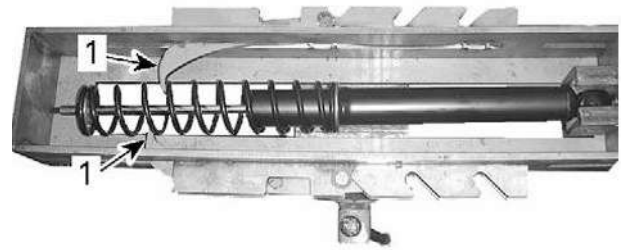

1. *Spring compressor hooks*

3. Tighten the spring compressor tool screw until the spring is sufficiently compressed to remove spring stopper.

4. Release the spring compressor tool screw.

5. Remove spring from shock absorber.

Inspection

Inspect spring for apparent damage, any defect such as scratches or rust can affect the spring durability.

When the adjustment is at the lowest preload, ensure that adjustment cam and spring stopper are not loose. They must be under spring pressure. Otherwise, the spring stopper might fall off.

Inspect the shock absorber for oil leakage or damage, inspect the bushing for wear or damage. If any damage is found, replace the rear shock absorber with a new one.

Extend and compress the piston several times over its entire stroke. Check that it moves smoothly and with uniform resistance with rod up. Any of the following conditions will denote a defective shock:

-A skip or hang up when reversing stroke at mid-travel.

-Seizing or binding conditions except at extreme end of either stroke.

-A gurgling noise after completing one full compression and extension stroke.

Replace shock if any these conditions are found.

Assembly and Installation

For assembly and installation, reverse the disassembly and removal process.

STABILIZER BAR

Removal

Remove M12 nut, then separate the ball joint and rear upper suspension arm.

Remove M12 nuts, then remove ball joint from stabilizer bar.

Remove four M8 bolts and clamps, then remove stabilizer bar from frame.

Inspection

Check whether the lining of the stabilizer is powdered or cracked. If so, please replace it with a new lining. Check the cushion for cracked or damaged. If so, please replace it with a new one. Check the stabilizer ball joint for damage, pitting, looseness, etc., and check the ball bellows for cracks, damage, powdering, etc. If so, please replace it with a new one.

Installation

For installation, reverse the removal process.

Use suspension grease to lubricate sway bar. There are two grease zerk on sway bar.

REAR STEERING KNUCKLE

Removal

Place the vehicle on jack stands and remove the appropriate wheel.

Remove wheel hub.

Remove M12 bolts and nuts, separate rear steering knuckle with the upper/lower suspension arm.

Remove rear steering knuckle.

Remove circlip.

Using bearing extractor to disassembly the bearing.

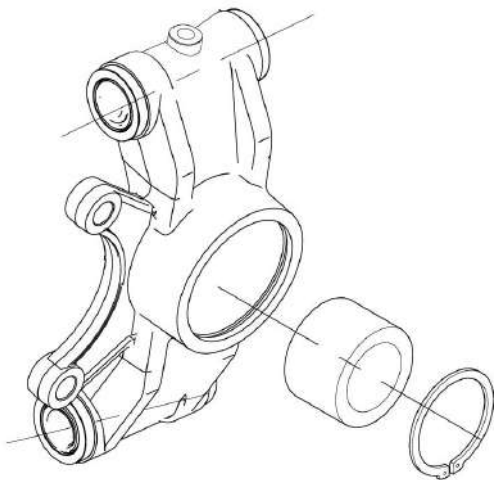

Inspection

Check steering knuckle for cracks or other damages. Replace if necessary.

Check if wheel bearing turns freely and smoothly.

Check Nylon sleeve and bushing in the rear steering knuckle. Replace if worn.

LOWER SUSPENSION ARM

Lubrication

Use suspension grease to lubricate both suspension arm. There are two grease zerk on each arm.

Inspection

Inspect the suspension arm and for damage or distortion. If any damages or distortion are found, replace the suspension arm with a new one.

Move suspension arm from side to side. There should be no noticeable loose. Replace bushing if necessary.

Move suspension arm up and down. There should be no noticeable loose. Replace bushing if necessary.

Inspect the bushing and Nylon sleeve for wearing or damaged. Replace if necessary.

Removal

Remove wheel.

Remove the M10 bolt and nut, separate the lower suspension arm and rear shock absorber.

Remove the M10 bolt and nut, separate the lower suspension arm and rear steering knuckle.

Remove the M12 bolts and nuts, separate the lower suspension arm from frame. Remove the lower suspension arm from frame.

Installation

For installation, reverse the removal process.

UPPER SUSPENSION ARM

Lubrication

Use suspension grease to lubricate both suspension arm. There are two grease zerk on each arm.

Inspection

Inspect the suspension arm and for damage or distortion. If any damages or distortion are found, replace the suspension arm with a new one.

Move suspension arm from side to side. There should be no noticeable loose. Replace bushing if necessary.

Move suspension arm up and down. There should be no noticeable loose. Replace bushing if necessary.

Check ball joint for damage, pitting, looseness and roughness. If so, replace it.

Check ball joint bellows for cracks. Change if necessary.

Removal

Remove wheel.

Remove the M12 nut, separate the upper suspension arm and ball joint.

Remove the M12 bolt and nut, separate the lower suspension arm and rear steering knuckle.

Remove the M12 bolts and nuts, separate the lower suspension arm from frame. Remove the lower suspension arm from frame.

Installation

For installation, reverse the removal process.

9. BRAKES SYSTEM

STRUCTURE.....	9-1	BRAKE FLUID REPLACMENT.....	9-2
BRAKE PADS REPLACMENT.....	9-2	BRAKE DISC.....	9-2
BRAKE CALIPER.....	9-3	BRAKE LIGHT SWITCH.....	9-3
BRAKE HOSE.....	9-3	FOOT BRAKE PEDAL.....	9-4
HANDBRAKE.....	9-4		

9.1 STRUCTURE

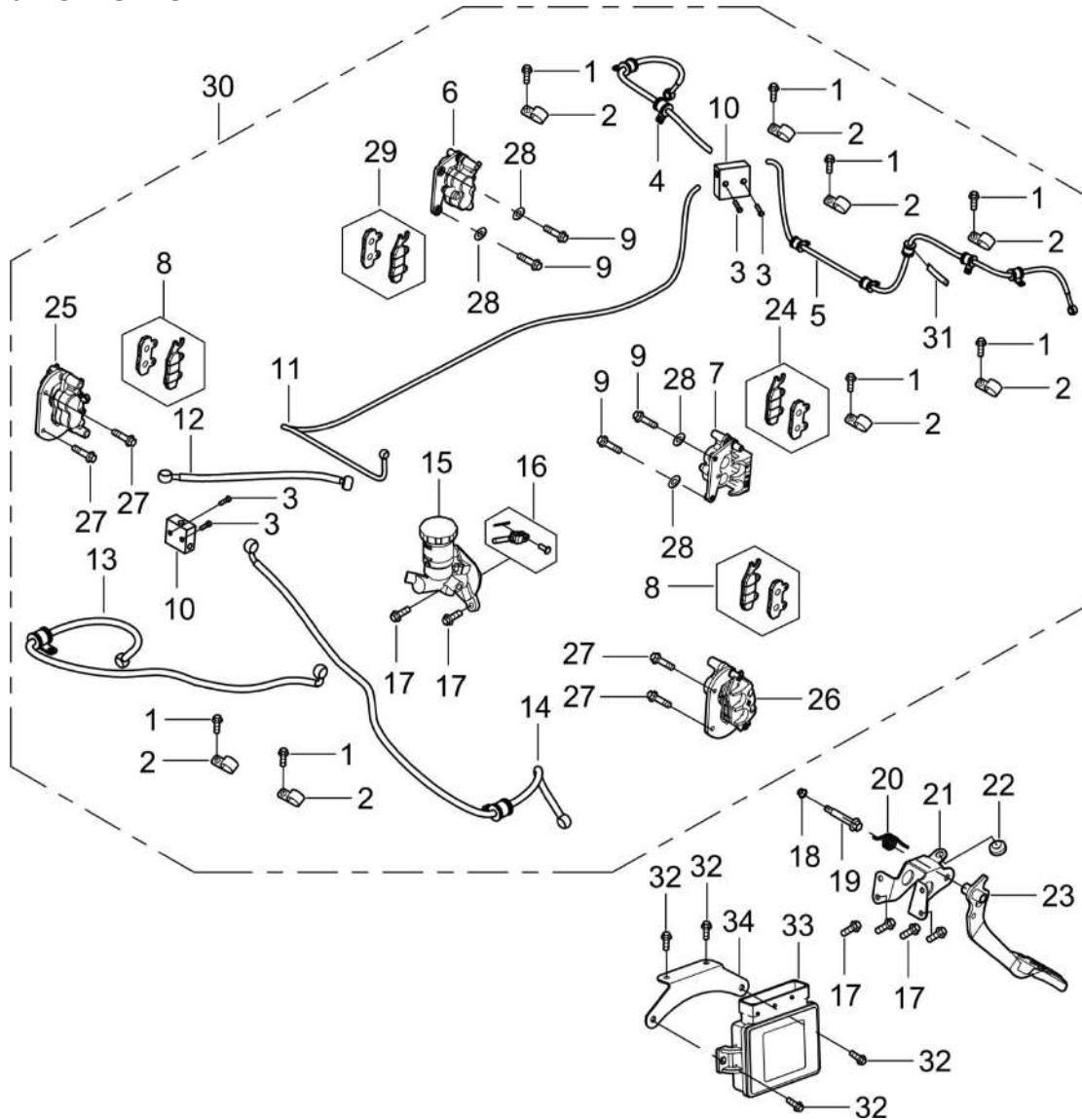

1. M6 Bolt	2. Clamp for brake oil pipe	3. M6 Bolt	4. Brake Hose
5. Brake Hose	6. RH Rear brake caliper	7.LH Rear brake caliper	8. Front Brake Pad
9. M10 Bolt	10. Rear Tee	11. Master Pump Copper Pipe	12. Master Pump Pipe
13. Front Right Pump Hose	14. Front Left Pump Hose	15. Brake Pump	16. Brake Rod
17. M8 Bolt	18. M8 Nut	19. M8 Bolt	20. Return Spring
21. Support Plate	22. Dump Bed Rubber	23. Foot Brake Pedal	24. Rear Brake Pad
25. RH front brake caliper	26. LH front brake caliper	27. M10 Bolt	28. Washer
29. Rear Brake Pad	30.Disc Brake	31. Wire holder	32. M6 Bolt
33. EPB	34. EPB Bracket		

GENERAL

The procedure explains how is the same for the RH and LH side unless otherwise instructed.

Clean thread before applying a thread locker.

⚠ WARNING

Torque wrench tightening specifications must be strictly adhered to.

Locking devices must be replaced with new ones when removed (e. g.: locking tabs, elastic stop nuts, self-locking fasteners, cotter pins, etc.).

NOTICE:

-This brake system is filled with an ethylene glycol-based DOT4 brake fluid.

-Do not use or mix different types of fluid, such as silicone-based or petroleum-based brake fluids.

-Do not use any brake fluid taken from old, used or unsealed containers. Never reuse brake fluid left over from the last servicing or which has been stored for a long period of time.

-When storing brake fluid, seal the container completely and keep it away from children.

-When replenishing brake fluid, take care not to get dust into fluid.

-When washing brake components, use new brake fluid. Never use cleaning solvent.

-A contaminated brake disc or brake pad reduces braking performance. Discard contaminated pads and clean the brake disc with high quality brake cleaner or neutral detergent.

-Brake fluid may cause damage to surfaces of plastic and rubber parts. Keep it far away from these parts.

MAINTENANCE

Brake Fluid

Recommended Brake Fluid

Always use brake fluid meeting the specification DOT 4 only.

⚠ WARNING

To avoid serious damage to the braking system, do not use fluids other than the recommended one, nor mix different fluids for topping up.

Brake Fluid Reservoir

Before riding, check that the brake fluid is above the lowest level and replenish it if necessary.

Place the vehicle on a level surface.

Brake fluid cap is near the LH shock absorber.

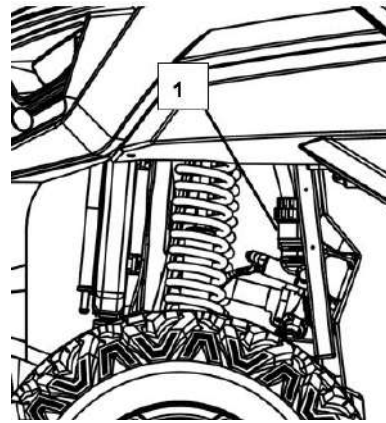

1. Brake fluid reservoir

Check the fluid level.

If fluid level is lower than the "lower" mark, add DOT4 brake fluid until the between two level lines.

⚠ WARNING

Never store or use a partial bottle of brake fluid. Brake fluid is hygroscopic, meaning it rapidly absorbs moisture from the air. The moisture causes the drop of boiling temperature of the brake fluid, which can lead to early brake fade and the possibility of accident or severe injury. After opening a bottle of brake fluid, always discard any unused portion.

Brake Fluid Replacement

⚠ WARNING

A contaminated brake disc or pad reduces stopping power. Discard contaminated pads and clean a contaminated disc with a high quality brake degreasing agent.

Brake Fluid Draining

Remove reservoir cover with its diaphragm.

Connect a clear hose to bleeding screw.

Loosen bleeding screw and press brake pedal until no more fluid flows out of bleeding screw.

Brake Fluid Filling and Bleeding

Close bleeding screws.

Fill reservoirs with DOT 4 brake fluid.

Unscrew the bleeding screw on the braking caliper until brake fluid comes out then close it.

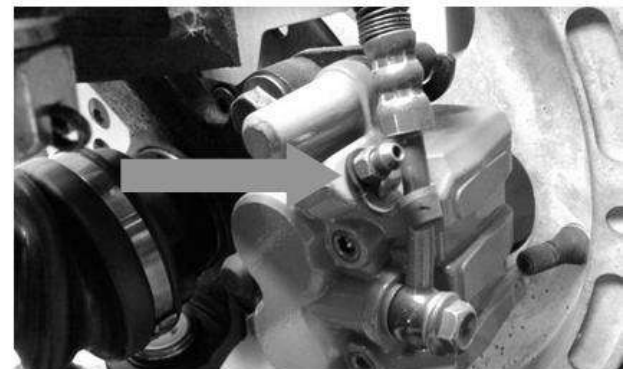

Bleeding screw

On each caliper, unscrew the bleeding screw until the brake fluid comes out then close it.

Bleed system as per the following procedure.

With a Vacuum Pump

Using a clear hose, install the vacuum/pressure pump (to bleeding screw). Place the pump in

vacuum position. See the manufacturer's operating instructions.

Pump vacuum pump loosen bleed. Close bleed and refill reservoir when the fluid level is low.

NOTE: Check fluid level often to prevent air from being pumped into the system.

Repeat the procedure until no more air bubbles appear in hose.

NOTE: For the front brake system, switch to LH and RH caliper. Turn steering wheel to full RH side when bleeding right caliper and turn to the LH side for the left caliper. This helps to reach air into the caliper. The front and the rear brakes must be bled at the same time.

Close bleeding screw and press brake pedal. If it still feels spongy, bleed system again.

Repeat the procedures until air bubbles do not appear in hose and brake pedal is stiff.

Fill reservoirs to the upper level with DOT 4 brake fluid.

Install diaphragms and covers on reservoirs.

Without a Vacuum Pump

If vacuum pump is not available, use the following procedure.

Install a clear hose to bleeding screw.

Open bleeding screw. Fill reservoirs and pump brake lever or brake pedal until fluid freely flows out of the hose.

Close bleeding screw.

Pump up system pressure with pressing brake pedal until pedal resistance is felt.

Press brake pedal, open bleeding screw and then close it.

NOTE: Do not release brake pedal until bleeding screw has been closed. For the front brake system, switch to LH and RH caliper. Turn steering wheel to full RH side when bleeding right caliper and turn to the LH side for the left caliper. This helps to reach air into the caliper. The front and rear brakes must be bled at the same time.

Release brake pedal slowly.

Repeat the procedure until no more air bubbles appear in hose and pedal is stiff.

Place the vehicle on a level surface.

Remove the brake pump cap and diaphragm.

Suck up the old brake fluid as much as possible.

Fill the reservoir with new brake fluid.

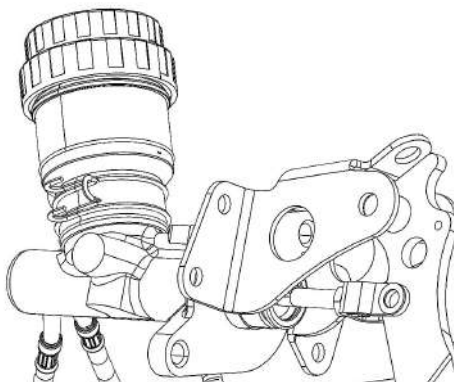

Remove the dust cap of air bleeder valve. Connect a clear hose to the air bleeder valve and insert the other end of the hose into a receptacle. Loosen the air bleeder valve and pump the brake

pedal until the old brake fluid is completely out of the brake system.

Close the air bleeder valve and squeeze and release the brake pedal several times in rapid succession and hold the pedal fully squeezed.

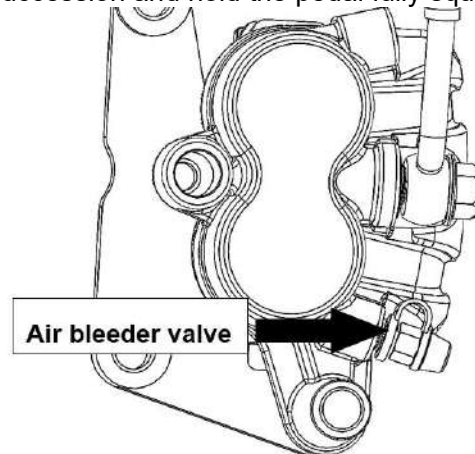

Loosen the air bleeder valve for about quarter of a turn so that the brake fluid runs into the receptacle, this will remove the tension of the brake pedal. Then close the bleeder valve, pump and squeeze the pedal and open the valve. Repeat this process until the fluid flowing into the receptacle contains no air bubbles.

Tighten the air bleeder valve to 6N.m.

Disconnect the clear hose and install the dust cap of air bleeder valve.

Fill the reservoir with new brake fluid to the upper edge of the inspection window.

Install the brake pump reservoir cap and diaphragm.

CAUTION: While bleeding the brake system, replenish the brake fluid in the reservoir as necessary. Make sure that there is always some fluid visible in the reservoir.

PROCEDURES

BRAKE LIGHT SWITCH

The brake light switch is located on the brake pump. It can not be adjusted.

Inspection

First ensure brake light is good.

Check switch for dirt or corrosion. Make sure it is operating properly.

Depress brake pedal and check for brake light to turn on. Repeat with the brake pedal.

Test

Disconnect switch connectors.

Check switch operation as follows.

SWITCH POSITION	PIN	RESISTANCE
Firmly pushed	1 2	0.2 Ω max
Released		Infinite

If switch is defective, replace with a new one. If switch tests good, check wiring harness.

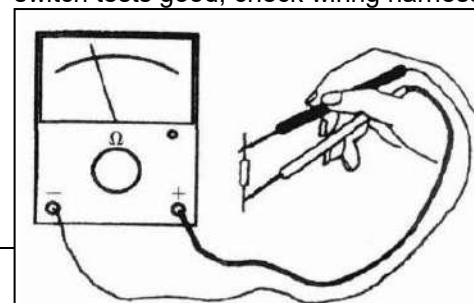

Removal

Disconnect switch connectors.
 Drain brake system.
 Unscrew brake light switch from master cylinder.
 Catch spilled fluid with a rag.

Installation

For installation, reverse the removal procedure.
NOTE: Apply Loctite 657(pipe sealant) on the threads of brake light switch.
 Bleed the brake system.
 Check for leaks and make sure the brakes operate normally before driving.

BRAKE PUMP

Removal

Drain brake fluid.
 Disconnect the brake light switch connector.
 Remove union bolt and copper washer, then remove brake hose from brake pump.
 Remove M8 bolts, then remove brake pump from frame.

Disassembly

Remove brake fluid reservoir cap, diaphragm and float from brake fluid reservoir.
 Remove dust boot and circlip, then remove piston spring from brake cylinder.

Inspection and Lubrication

Discard any remaining fluid inside reservoirs.
 Clean reservoirs, pistons and brake cylinders thoroughly with clean brake fluid.

Check:

- dust boots for crack
- springs for damage
- piston cups for wear, deterioration or damages
- master cylinders and pistons for scoring, scratches or other damages.

Change part(s) if necessary.

Check if brake fluid reservoir cap, diaphragm and float are brittle, hard or damaged.

NOTE: If master cylinder housing is damaged or leaking, replace as an assembly.

Assembly

Install:

- spring
- piston
- circlip
- boot.

Then install brake fluid reservoir cap, diaphragm and float to brake fluid reservoir.

Installation

Install brake cylinder to frame.
 Fill reservoir with clean brake fluid.
 Bleed brake system.
 Check for leaks and make sure the brakes operate normally before driving.

Connect brake light switch connectors.

BRAKE CALIPER

Removal

Loosen wheel nuts.
 Raise vehicle and support it securely.
 Remove appropriate wheel.

Loosen the M10 bolts then remove the brake caliper from steering knuckle. If the caliper is not being removed from the vehicle as during brake pad replacement, simply hang the caliper with a piece of wire to take the weight off the brake hose.

CAUTION: Do not let caliper hangs by the hose and do not stretch or twist the hose.

Disconnect the EPB connector from the front brake caliper.

If the caliper is being removed for replacement, drain brake system before removing the Banjo fitting and washer.

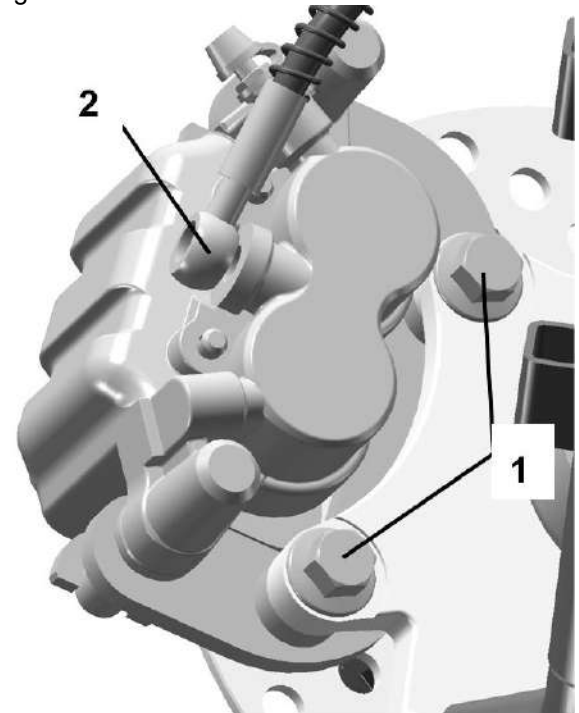

1. Unscrew M10 bolts

2. Remove banjo fitting and washers

Catch spilled fluid with a rag. Attach the brake hose in a position to prevent the fluid from flowing out.

Disassembly

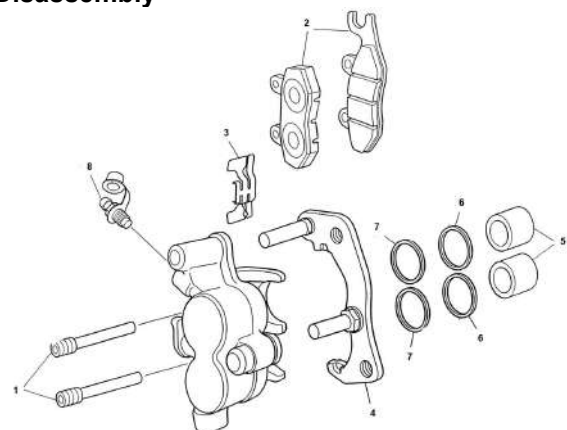

1.Brake pad hloading bolt

2.Brake pad

3.Pad spring

4.Caliper bracket

5.Brake caliper piston

6.Dust seal

7.Caliper piston seal

8.Bleed screw

Remove brake pads, see the following section.

Loosen M6 bolts, then remove EPS motor from front brake caliper.

Remove:

- caliper bracket
- pad spring.

Place a rag over the caliper piston.

Place caliper body with piston down and apply small squirts of air pressure to the fluid to remove the brake caliper piston.

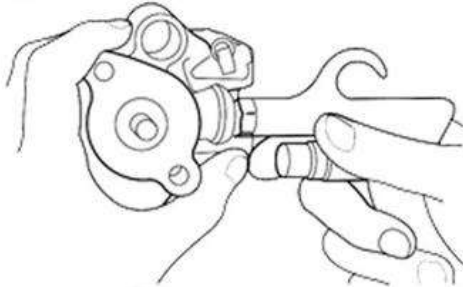

WARNING

- NEVER try to pry out a caliper piston.
- Be careful not to get injured when the piston is expelled from the caliper cylinder.
- Be careful not to damage piston sliding surface.

Remove dust seal and piston seal.

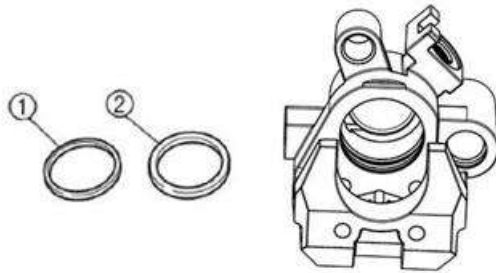

1. Caliper dust seal
2. Caliper piston seal

Clean piston grooves, caliper cylinder and piston with clean brake fluid.

Clean slide pins with brake cleaner and a rag.

Inspection

Recommended replacement schedule:	brake component
Brake pads	As required
Piston seals, dust seals	Every two years
Brake hoses	Every four years
Brake fluid	Replace when brakes are disassembled

WARNING

All internal brake components should be cleaned in new brake fluid only. Do not use solvents as they will cause seals to swell and distort.

If boots are deteriorated or hard, replace with new ones.

Check caliper cylinder for scratches or wear. If so, replace caliper.

Check piston for scratches, rust or other damages. If so, replace piston.

Check brake caliper body for crack or damage. If so, replace brake caliper body.

Check brake caliper body for blockage. If so, blow out with compressed air.

WARNING

Replace the caliper piston seals and dust seal whenever the brake caliper is disassembled.

Assembly

Coat new piston seal with clean brake fluid and install it into piston grooves in caliper.

Coat piston with clean brake fluid and install into cylinder with the closing toward caliper body.

Install pad spring, caliper bracket and pads.

Torque M6 bolts for EPB motor to torque: 22Nm.

Insert the EPB connector.

Installation

For the installation, reverse the removal procedure.

Install caliper in its original position.

Torque M10 mounting bolts for brake caliper to torque: 48Nm.

Use new sealing washers when installing banjo fitting retaining brake hose to caliper.

Torque union bolt for brake hose to torque: 27Nm.

Fill the brake reservoir with recommended brake fluid DOT4.

CAUTION: Brake fluid may damage painted surface or plastic parts. Always clean up spilled brake fluid immediately.

WARNING

-Use only the designated quality brake fluid: other brake fluids may deteriorate the rubber seals, causing leakage and poor brake performance.

-Refill with the same type of brake fluid: mixing brake fluids may result in a harmful chemical reaction and lead to poor brake performance.

-Be careful that water does not enter the master cylinder when refilling. Water will significantly lower the boiling point of the brake fluid and may result in vapor lock.

Bleed the brake system.

Check brake fluid level and leaks to make sure the brakes operate normally before driving.

BRAKE PADS

Remove the wheel.

Remove brake caliper.

Remove the brake caliper mounting bolt and brake pads holding bolts.

Remove the brake pads and springs.

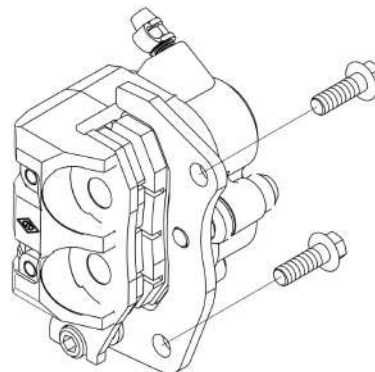

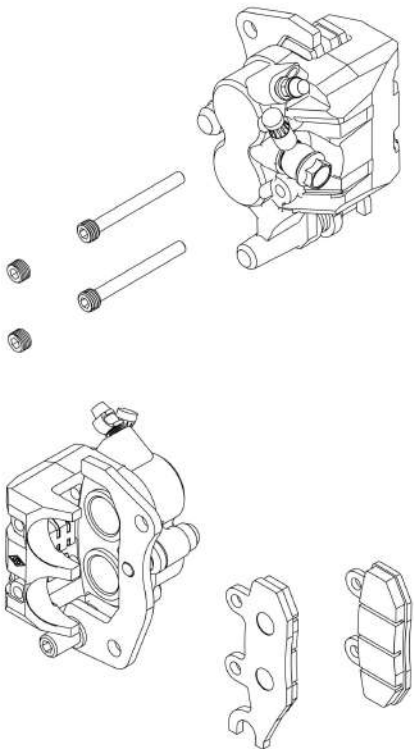

⚠WARNING

Disc brake components rarely require disassembly. **DO NOT:**

- disassemble components unless absolutely necessary;
- use solvents on internal brake components;
- use spent brake fluid for cleaning; (use only clean brake fluid)
- allow brake fluid to come in contact with the eyes, as this may cause eye injury;
- splash brake fluid onto painted surfaces or plastic parts, as this may cause damage;
- disconnect any hydraulic connection, as this would require the entire brake system to be disassembled, drained, cleaned, properly filled and bled after reassembly.

Inspection

CAUTION: Do not clean brake pads in petroleum-based solvent. Use brake system cleaner only. Soiled brake pads must be replaced with new ones.

Measure brake pad thickness.

Brake pads must be replaced when pad is 1.5 mm thick or less, or look the hollow places on both sides on the pad lining.

There are three hollow places on one set of brake pads. When the pad wear reaches one of the hollow places, the pad must be changed even if the pad wear does not reach another hollow place.

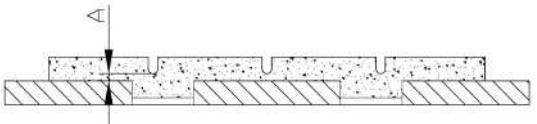

Brake pad wear limit	1.5 mm
----------------------	--------

⚠WARNING

Avoid getting oil or grease on brake pads. Contaminated brake pads can affect stopping capacities.

CAUTION: Brake pads must always be replaced in pairs.

Installation

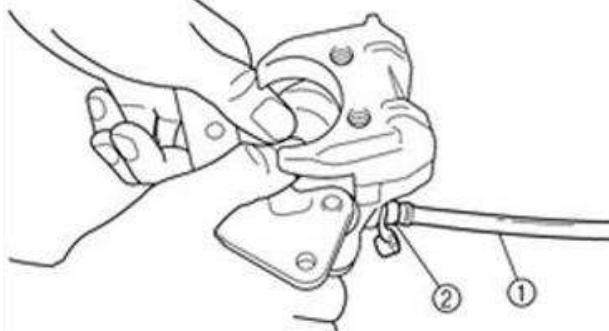

- 1. Brake oil hose
- 2. Brake caliper bleed screw
- Connect a suitable hose tightly to the brake caliper bleed screw. Put the other end of this hose into an open container.
- Loosen the brake caliper bleed screw and using a finger push the caliper piston into the brake caliper.
- Tighten the brake caliper bleed screw to 6Nm.
- Install the new brake pads and a new brake pad spring.
- Tighten the brake pad holding bolts to 18Nm and brake caliper bolts to 44~48Nm.

CAUTION: Always install new brake pads and brake pad spring as a set. Do not operate the brake pedal during or after brake pad removal. After replacing the brake pads, pump the brake pedal a few times to check for proper brake operation and then check the brake fluid level.

BRAKE DISC

Inspection

Brake discs can be inspected without removing them from the vehicle.

Raise vehicle and support it securely. Remove wheels and visually inspect disc surfaces for scratches or grooves. Make sure to check both sides of disc.

Measure thickness of the disc.

Front/Rear Disc Minimum Thickness	4.0 mm
-----------------------------------	--------

Replace disc if out of specifications.

Measure the deflection of brake disc. If the deflection exceeds the service limit, replace the brake disc with a new one.

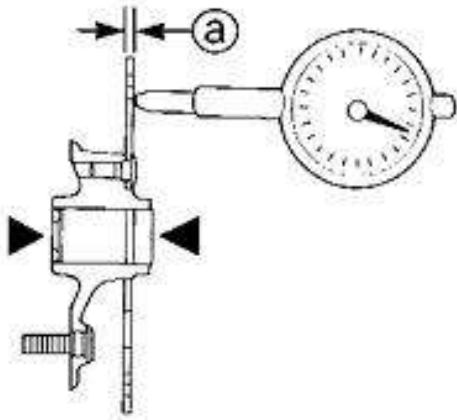

Maximum deflection of brake disc: 0.1mm.

Removal

- Raise the vehicle.
- Remove appropriate wheel.
- Remove caliper as described previously. Do not disconnect brake hose from caliper.
- Remove the cotter pin, the castle nut and the washer. Discard cotter pin.
- Pull out wheel hub with brake disc.
- Heat up brake disc around screw to break the thread locker. Remove and discard brake disc screws.



- 1. Brake disc screws
- 2. Brake disc

Separate brake disc and wheel hub.

Installation

For the installation, reverse the removal procedure. Tighten the screws for brake disc bolts to 30Nm.

BRAKE HOSES

Inspection

Brake hoses should be inspected frequently for leaks and damages. Check if the hoses are crushed or damaged. Any deformation can restrict the proper flow of fluid and cause braking problems. Check hoses for cracking or scrape s. This damage can cause hose failure under pressure. When hoses are removed or disconnected, cleanness must be observed. Clean all joints and connections before disassembly. New hoses should

be cleaned with brake fluid before installation to remove any contamination. Replace any defective parts.

Removal

NOTE: Before removing any hoses, drain brake system.

Remove all necessary parts to reach the hoses. Thoroughly clean the area around the joints that will be disconnected.

Place a drain pan under the joint that will be disconnected.

Disconnect any retaining clips or brackets holding the hose and remove the defective part(s).

Installation

Install the new hose.

Make sure the piece will not rub against any other part.

When there is a banjo fitting securing the hose to the caliper or to the master cylinder, always replace the sealing washers with new ones.

Install any retaining clips or brackets. Refill and bleed the system.

FOOT BRAKE PEDAL

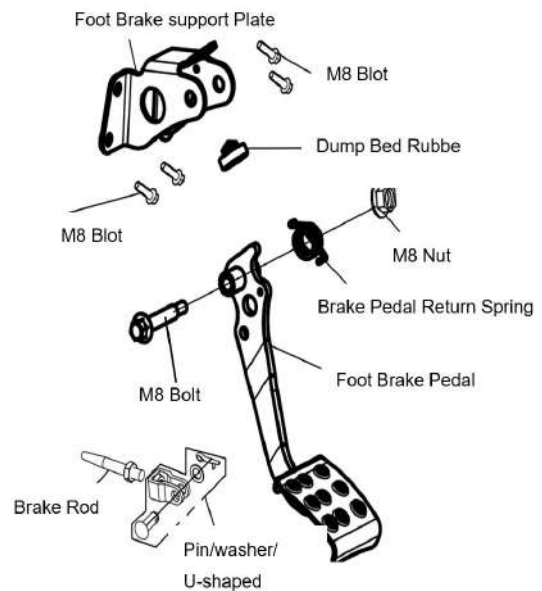

Dismantling

Remove the pin and pin shaft, then separate the brake pedal and brake rod of master cylinder.

Loosen four M8 bolts, remove the foot brake support plate.

Loosen M8 bolt and nut, remove foot brake pedal and return spring from support plate.

Inspection

The brake pedal stroke is 30 ~ 40mm. If less than equal 30mm, it will be a hidden dangers, must adjust the brake pin connecting the brake pedal.

Tightening torque of M8 bolts: 22 ~ 30N.m.

10. CHASSIS

EXTERNAL COMPONENTS.....	10-1	AIR INLET AND EXHAUST SYSTEM.....	10-4
AIR FILTER& CVT INTAKE & EXHAUST SYSTEM	10-5	EXHAUST SYSTEM.....	10-6
GEAR SHIFT LEVER	10-7	CARGO BOX.....	10-8
SEAT.....	10-9	FRONT AND REAR WINDSHIELD.....	10-10
HALF-WINDSHIELD.....	10-11	FRONT DOOR.....	10-12
HALF DOOR.....	10-13	ROOF.....	10-14
ROLL BAR AND INNER MIRROR.....	10-15	HEATING SYSTEM (FOR HV VERSIN).....	10-16
SNOW SHOVEL.....	10-17		

10.1 EXTERNAL COMPONENTS

Front panel

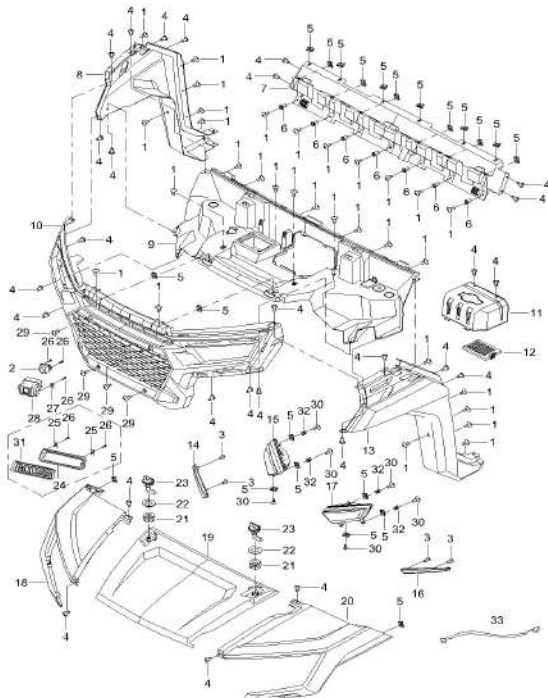

Loosen M6 screw ,then remove push pin and front guard plate.

Turn the rotation switch and remove the center front panel.

Remove push pins and front panel.

Loosen M6 screws and nuts, then remove groove box.

Loose four M8 bolts and then remove the front bump from frame.

Remove push pin and headlight cover.

Loose four M8 bolts and then remove winch bracket.

Loose four M8 bolts and then remove winch.

Loosen M6 screws and nuts, then remove radiator cap and front panel liner.

Loosen M6 screws and rivet nuts, then remove push pins, plate nuts and dashboard bracket.

Tightening torque of M6 bolts: 9-12Nm.

Tightening torque of M8 bolts: 22-30Nm.

Available overhaul: Replace front bumper and winch.

Rear bumper

Loose four M10 bolts and nuts,then remove the rear bumper from frame.

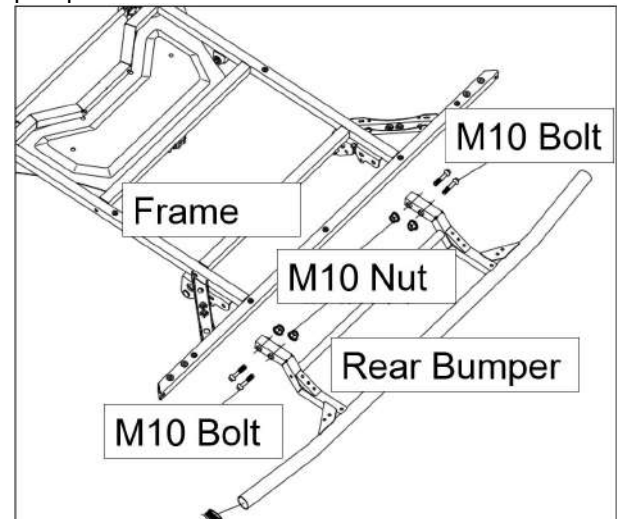

Tightening torque of M10 bolts: 65-78Nm.

Available overhaul: Replace rear bumper.

Foot board and front driveshaft shield(Single row)

Remove push pin and front driveshaft shield.

Loose M6 screws and then remove foot board.

Rear Mudguard

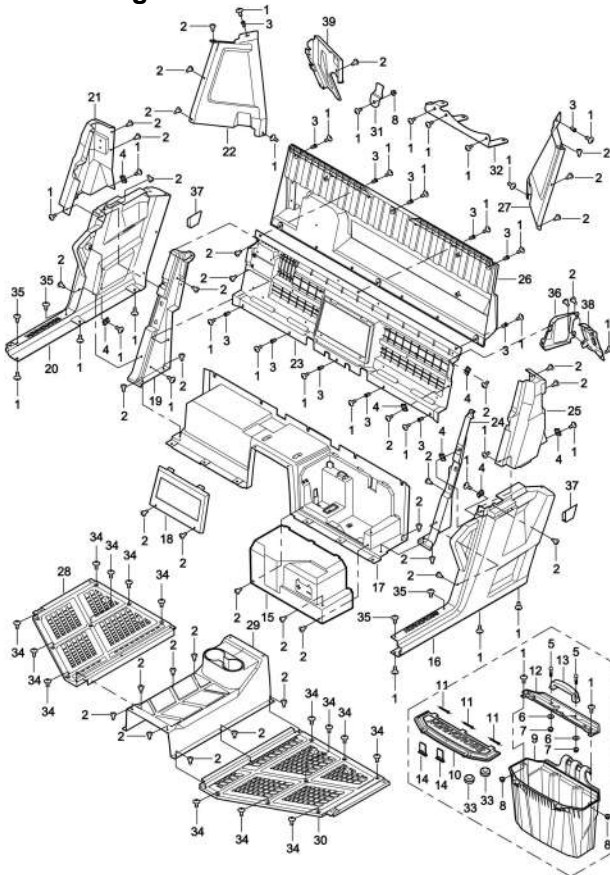

Tilt cargo box. Remove push pin and air filter cover. Loosen M6 screws, then remove push pin and rear mudguard.

Loosen M6 screws, then remove push pin and upper rear side panel.

Loosen M6 screws and nuts, then remove push pin and lower rear side panel outer.

Remove seat. Remove M6 nuts, push pin and rear side panel inner.

Remove rear windshield, air filter, CVT inlet pipe, BCM and fuses. Remove M6 screws and seat back guard plate.

Remove M6 screws and push pin, then remove seat back guard plate 1.

Remove push pin and battery cover.

Remove battery fixing plate and battery.

Remove starter relay.

Remove M6 screws and push pin, then remove seat bottom guard plate.

Dash Board(Without HV)

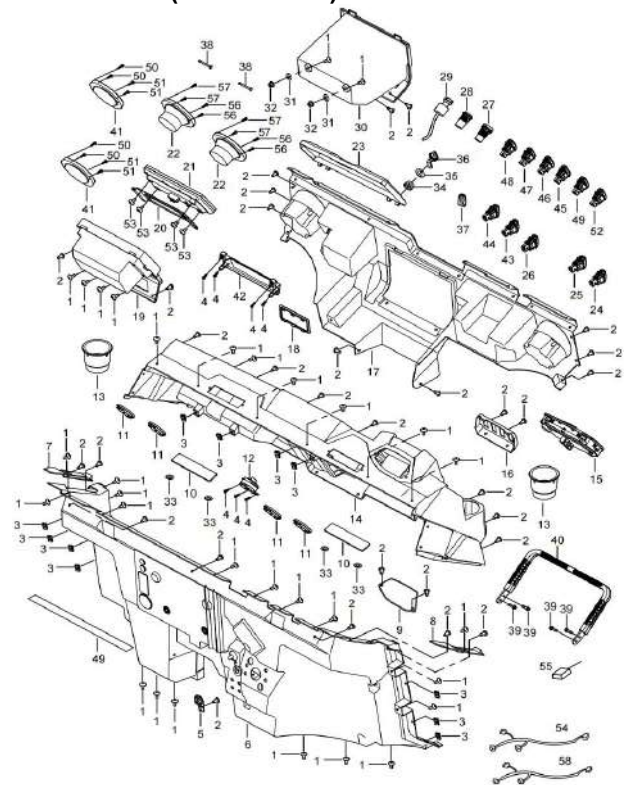

Remove steering wheel, steering column bracket and gas spring.

Remove push pin and dash display cover.

Remove harness and M6 screws, then remove dash display.

Loosen M8 bolts, then remove passenger armrest.

Remove push pin and central control screen mounting plate.

Remove front windshield.

Remove M6 screws and push pin, then remove dash board.

Remove gearshift lever, 2WD/4WD switch, steering system and ECU.

Remove M6 screws and nuts, then remove dash board bracket.

Remove brake pedal, brake pump and accelerator pedal.

Remove M6 screws, nuts and push pin, then remove dashboard lower guard plate.

Dash Board(With HVAC or HV)

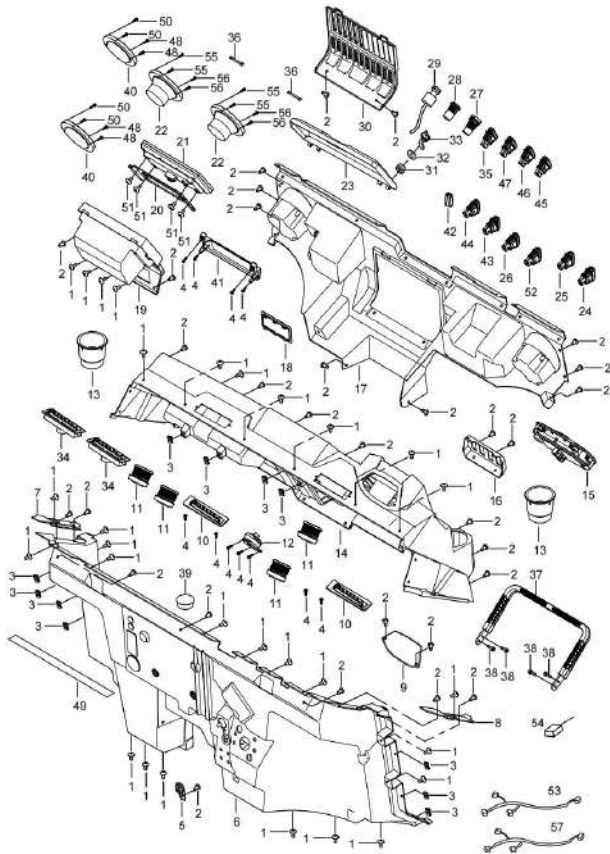

Remove steering wheel, steering column bracket and gas spring.

Remove push pin, dash display cover and A/C service cover.

Remove harness and M6 screws, then remove dash display.

Loosen M8 bolts, then remove passenger armrest.

Remove push pin and central control screen mounting plate.

Remove screws and speaker cover.

Remove front windshield.

Remove M6 screws and push pin, then remove dash board.

Remove adjustment vent, gearshift lever, 2WD/4WD switch, steering system and ECU.

Remove M6 screws and nuts, then remove dash board bracket.

Remove brake pedal, brake pump and accelerator pedal.

Remove M6 screws, nuts and push pin, then remove rear inner mudguard.

10.2 AIR INTAKE AND EXHAUST SYSTEM

Structure

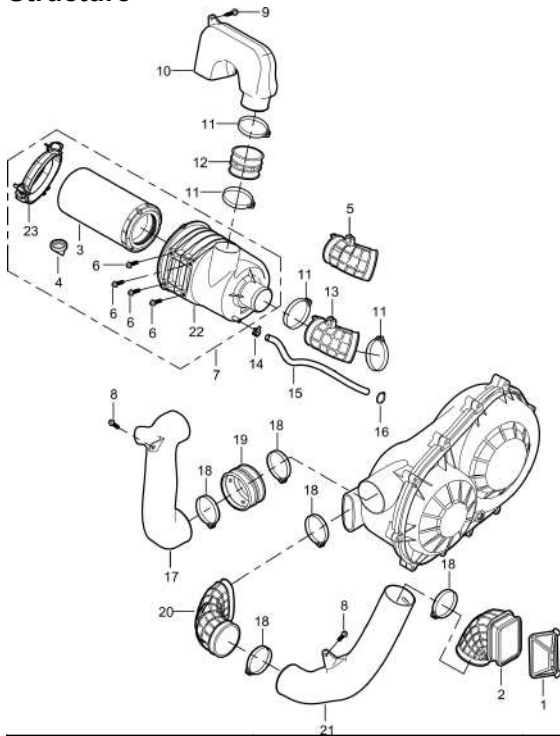

1.CVT Air Intake Pipe Filter	2. CVT Air Intake Pipe	3.Air Filter	4. Air Filter Drain Sleeve	5. Air Intake Pipe
6. M8 Bolt	7. Air Filter Assembly	8. M6 Bolt	9. ST5.5 Screw	10. Primary Air Filter
11. Clamp	12. Primary Air Filter Rubber Sleeve	13. Air Intake Pipe	14. Clamp	15. Crankcase Ventilation Pipe
16. Clamp	17. CVT Exhaust Rubber Hose	18. Clamp	19. CVT Exhaust Pipe	20. CVT Intake Pipe
21. CVT Intake Pipe	22. Air Filter Upper Shell	23. Air Filter End Cover		

Dismantling

CVT air intake pipe combination

Tilt cargo box.

Loosen M6 screw and push pin, then remove CVT intake mounting cover and CVT intake cover.

Loosen the clamp and then remove CVT air intake pipe filter.

Loosen M6 bolts and nuts. Loosen the clamps for the CVT air inlet pipe at one time. After loosening, maintenance and replacement of relevant parts can be carried out.

Available overhaul: replace CVT intake pipe combination.

CVT air exhaust pipe combination

Remove the M6 bolts and loosen the clamps. Then the relevant components of air outlet pipe combination can be maintained.

Available overhaul: replace CVT air outlet pipe combination.

Tightening torque of M6 bolts: 9-12Nm.

Air filter combination

Tilt cargo box.

Loosen the clamp and then remove the crankcase ventilation pipe.

Loosen the clamps and then remove air filter intake pipe.

Loosen the clamps and then remove primary air filter.

Loosen the four M8 bolts and remove the air filter assembly.

Remove the air filter end cover. Pull out the air filter from upper shell. The filter element can be cleaned or replaced after removal.

Available overhaul:

Replace and conduct daily maintenance of air filter combination.

Tightening torque of M8 bolts for air filter upper shell: 22~30Nm.

10.3 AIR FILTER & CVT INTAKE & EXHAUST SYSTEM(If equipped)

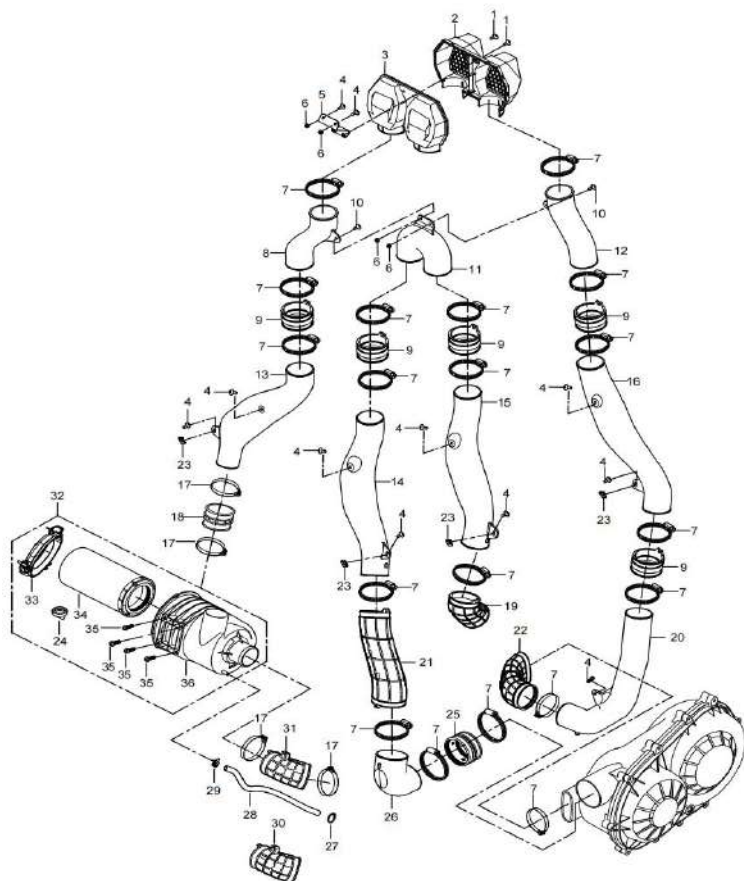

1.M6 Screw	2. Intake Grille Upper Cover	3. Intake Grille Lower Cover	4. M6 Screw	5.CVT Tee Mounting Plate
6.M6 Nut	7.Clamp	8. Air Filter Intake Pipe 1	9. CVT Rubber Sleeve	10. M6 Screw
11. CVT Exhaust Pipe 3	12. CVT Intake Pipe 1	13. Air Filter Intake Pipe 2	14. CVT Exhaust Pipe 2	15. CVT Exhaust Pipe 4
16. CVT Intake Pipe 2	17. Clamp	18.Primary Air Filter Rubber Sleeve	19. CVT Exhaust Rubber Sleeve 2	20. CVT Intake Pipe 3
21. CVT Exhaust Rubber Sleeve 1	22. CVT Intake Pipe Boot	23. M6 Plate Nut	24. Air Filter Drain Sleeve	25. CVT Intake Pipe Boot
26. CVT Exhaust Pipe 1	27.Clamp	28.Crankcase Ventilation Pipe	29.Clamp	30. Air Filter Intake Pipe 1(1000cc)
31. Air Filter Intake Pipe 1(800cc)	32. Air Filter Assembly	33. Air Filter End Cover	34. Air Filter	35.M8 Bolt
36.Air Filter Upper Shell				

Dismantling

1. Tilt cargo box. Loosen M6 screws, then remove air intake grille upper and lower cover.
2. Loosen M6 screws and clamps, then remove CVT intake pipe and CVT rubber sleeve from CVT.
3. Loosen M6 screws and clamps, then remove CVT exhaust pipe and CVT rubber sleeve from CVT.
4. Loosen M6 screws and clamps, then remove air filter intake pipe and CVT rubber sleeve from air filter assembly.
5. Loosen clamps, remove the air filter intake pipe between throttle body and air filter.
6. Loosen clamp, remove crankcase ventilation pipe from air filter assembly.
7. Loosen M8 bolts, remove air filter assembly from frame.
8. Remove the air filter end cover. Pull out the air filter from upper shell. The filter element can be cleaned or replaced after removal.

Replace and conduct daily maintenance of air filter combination.

Tightening torque of M8 bolts for air filter upper shell: 22~30Nm.

Tightening torque of M6 bolts:9~12Nm.

10.4 EXHAUST SYSTEM

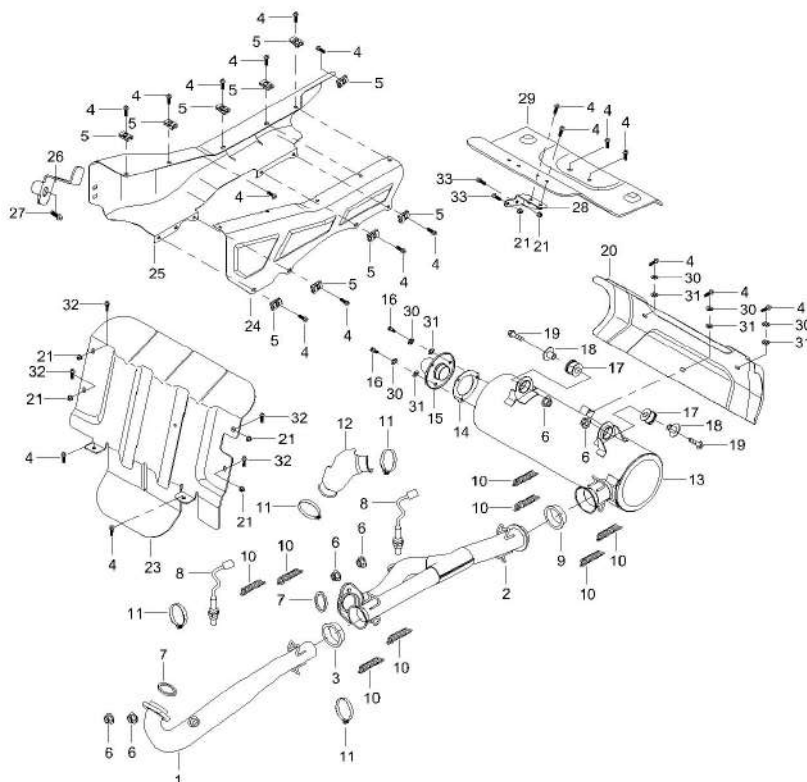

1.Cylinder Exhaust Pipe	1	2. Cylinder Exhaust Pipe	2	3.Graphite Seal Sleeve	4.M6 Bolt	5.Clip
6.M8 Nut		7. Exhaust Gasket		8. Oxygen Sensor	9. Graphite Seal Sleeve	10. Exhaust Pipe Tension Spring
11. Clamp		12. Exhaust Pipe Heat Shield		13. Muffler	14. Graphite Washe	15. Graphite Washe
16. M6 Nut		17. Muffler Hang Rubber Sleeve		18. Muffler Hang Neck Bushing	19. M8 Bolt	20. Muffler Body Protective Board
21. M6 Nut		22. M6 Rivet Nut		23. Engine Heat Shield	24. Exhaust Pipe Heat Shield (Outer)	25. Exhaust Pipe Heat Shield (Inner)
26. Exhaust Pipe Heat Front Mounting Plate		27. M10 Bolt		28.Transmission Heat Plate Rear Mounting Plate	29.Transmission Heat Plate	
31.Washer		32. M6 Screw		33.M6 Bolt		

▲ WARNING

Be careful not to operate when the engine is running or the muffler is at high temperature.

Dismantling

1. Tilt cargo box. Remove engine heat shield, exhaust pipe heat shield, muffler body protective board and transmission heat plate.
2. Remove the oxygen sensor from the exhaust pipe.
3. Remove the two M8 nuts between the cylinder 1 exhaust pipe and the engine.
4. Remove the exhaust pipe tension springs on the cylinder 1 and cylinder 2 exhaust pipe. Remove cylinder 1 and cylinder 2 exhaust pipes.
5. Loosen M8 bolts and remove the muffler from the frame.

Inspection

1. Check the leaks in exhaust pipe and the cracks in heat insulating shield.
2. Check whether the rubber parts in silencer are cracked or weathered, etc.
3. Clean the sundries and inspect any damage in the fire-retardant net.

If there is any problem, please replace it with a new one.

▲ WARNING

After dismantling muffler, seal gasket of exhaust pipe should not be used repeatedly; new component should be used upon installation.

To prevent exhaust pipe leakage, high polymer sealant should be applied to cylinder exhaust pipe port and surface of exhaust pipe seal gasket upon muffler assembly installation.

Tightening torque of M8 bolts for exhaust pipe and muffler: 22~30Nm.

Tightening torque of M6 bolts for exhaust pipe and muffler: 9~12Nm.

10.5 GEARSHIFT LEVER AND THROTTLE PEDAL

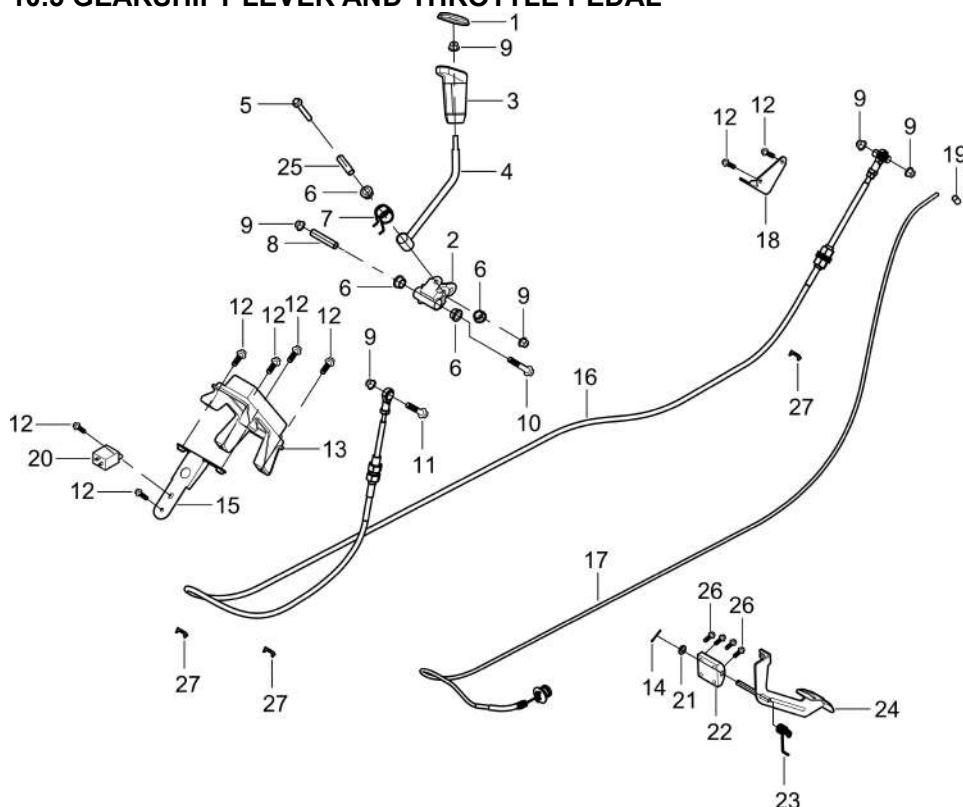

1. Shift Lever Upper Cover	2. Gearshift Lever Cross Shaft	3. Shift Lever Lower Cover	4. Shift Lever
5. M8 Bolt	6. Steering Nylon Sleeve	7 Return Spring	8. Long Neck Bush
9. M8 Nut	10. M8 Bolt	11. M8 Bolt	12. M6 Bolt
13. Shift Plate	14. Cotter Pin	15. Shift Support Plate	16. Gearshift Cable
17. Accelerator Cable	18. Gearshift Cable Fixed Plate	19. Copper Buckle	20. Flasher
21. Washer	22. Throttle Pedal Mounting Base	23. Throttle Pedal Return Spring	24. Throttle Pedal
25. Short Neck Bush	26. M6 Screw	27. Clamp	

Dismantling

Loosen nut on throttle pedal, then remove the accelerator cable.

Loosen M6 screw and remove pedal return spring.

Remove the cotter pin, washer and throttle pedal.

Loosen M6 screws and remove throttle pedal mounting base.

Loosen M14 nut and M8 nuts, then remove gearshift cable from gearshift arm on the engine.

Remove dash board.

Loosen M6 bolts and remove shift plate.

Loosen M6 nuts and remove shift support plate.

Loosen M8 bolt and nut, then remove shift lever.

Inspection

Check whether return spring, throttle pedal, accelerator cable, gearshift cable, and shift lever are cracked or damaged. Available overhaul: Replace gear shift handle combination.

Tightening torque of M6 screw: 9-12Nm.

Tightening torque of M8 bolts: 22~30Nm.

10.6 CARGO BOX

Dismantling

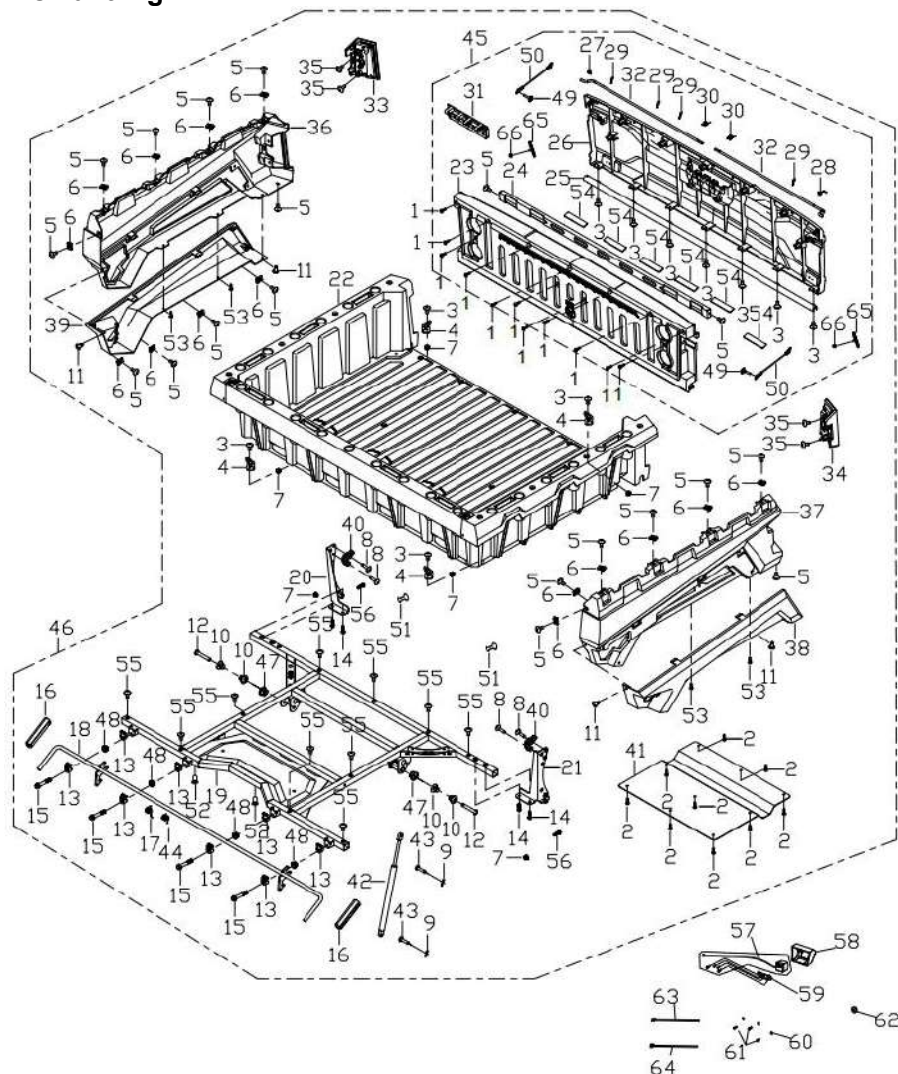

Tilt cargo box.

Loose the M12 bolts and nut, then remove the pivot shaft.

Remove dump bed lower fixation pin and R pin, then remove the dump bed air springs from cargo box.

Remove the cargo box from frame.

Loosen M6 screws, nuts and push pin, then remove rear fender.

Loosen M6 screws, nuts and ST5.5 screws, then remove cargo box guard plate.

Loosen ST5.5 screws, then remove cargo box rear door.

Inspection

Check for the following conditions, if damaged, please replace it with a new one in time.

1. Whether the door panels of the cargo box are damaged.
2. Whether there is any obvious damage or breakage on the skin of the cargo box.

▲ WARNING

Be careful not to operate when the engine is running or the silencer is at high temperature.

Check whether the nylon sleeve is worn seriously. If there is cracked, please replace it in time

Check whether the cargo body handle spring is deformed after stretching. If it is deformed, please replace it in time.

Check the cargo body handle limit rubber and replace it in time if cracked.

Check whether the rubber mount at the bottom of seat is cracked, if there is cracked need to replace it in time.

Cargo body air spring inspection

1. Whether the piston is moving smoothly during stretching and compressing, has balanced resistance, and its pull rod upward.

2. A suddenly fracture in stretching or compressing.

3. Unable to stretch or have noise after compression.

If there is any problem, please replace it with a new one.

Tightening torque of M6 bolts for cargo box: 9~12Nm.

Tightening torque of M12 bolts for pivot shaft: 78~104Nm.

10.7 SEAT

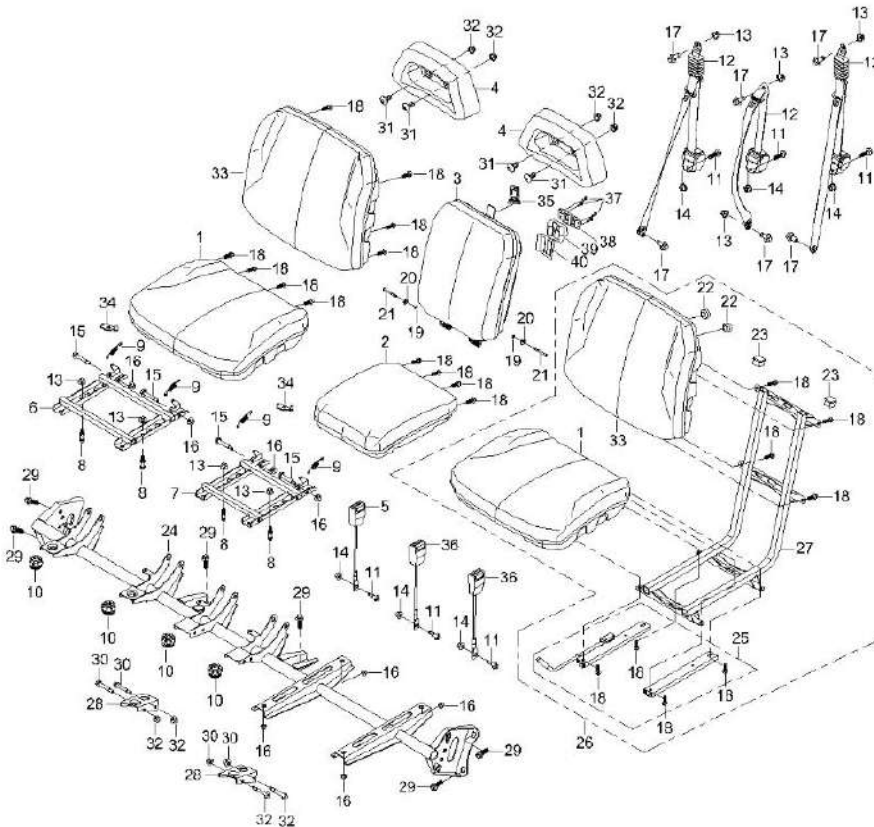
**Dismantling**

Remove rear windshield.

Loosen M6 screws and nuts, then remove the seat headrest from rear canopy rod.

Tilt cargo box, then remove seat back guard plate.

Loosen M8 screws, then remove main seat combination from front seat bracket.

Loosen M8 screws, then remove seat, backrest and driver seat slide from driver seat bracket.

Loosen M8 screws, then remove passenger backrest from rear canopy rod.

Loosen M8 screws, then remove passenger seat from passenger seat mounting bracket.

Loosen M10 bolts, then remove seat belt from front seat bracket.

Loosen M11 bolts and nuts, then remove seat belt from rear canopy rod.

Loosen M8 bolts, nuts and seat cushion springs, then remove passenger seat mounting bracket.

Remove lower rear side panel, loosen M10 bolts, then remove front seat bracket from frame.

Loosen M11 bolts and nuts, then remove seat belt fixation lock.

Inspection

Long-term exposure of the seat to sunlight can cause some wear on its components.

1. Check whether the following parts of the seat are cracked or severely worn, etc. If they are replaced, please

- (1) Seat cushion spring
- (2) Seat rubber washer

2. Check the seat leather for cracks, damage, etc., please replace it in time.

3. Check whether the safety belt can return to the retractor after stretching, if can not, please replace it with a new one in time.

10.9 Front and Rear Windshield (If equipped)

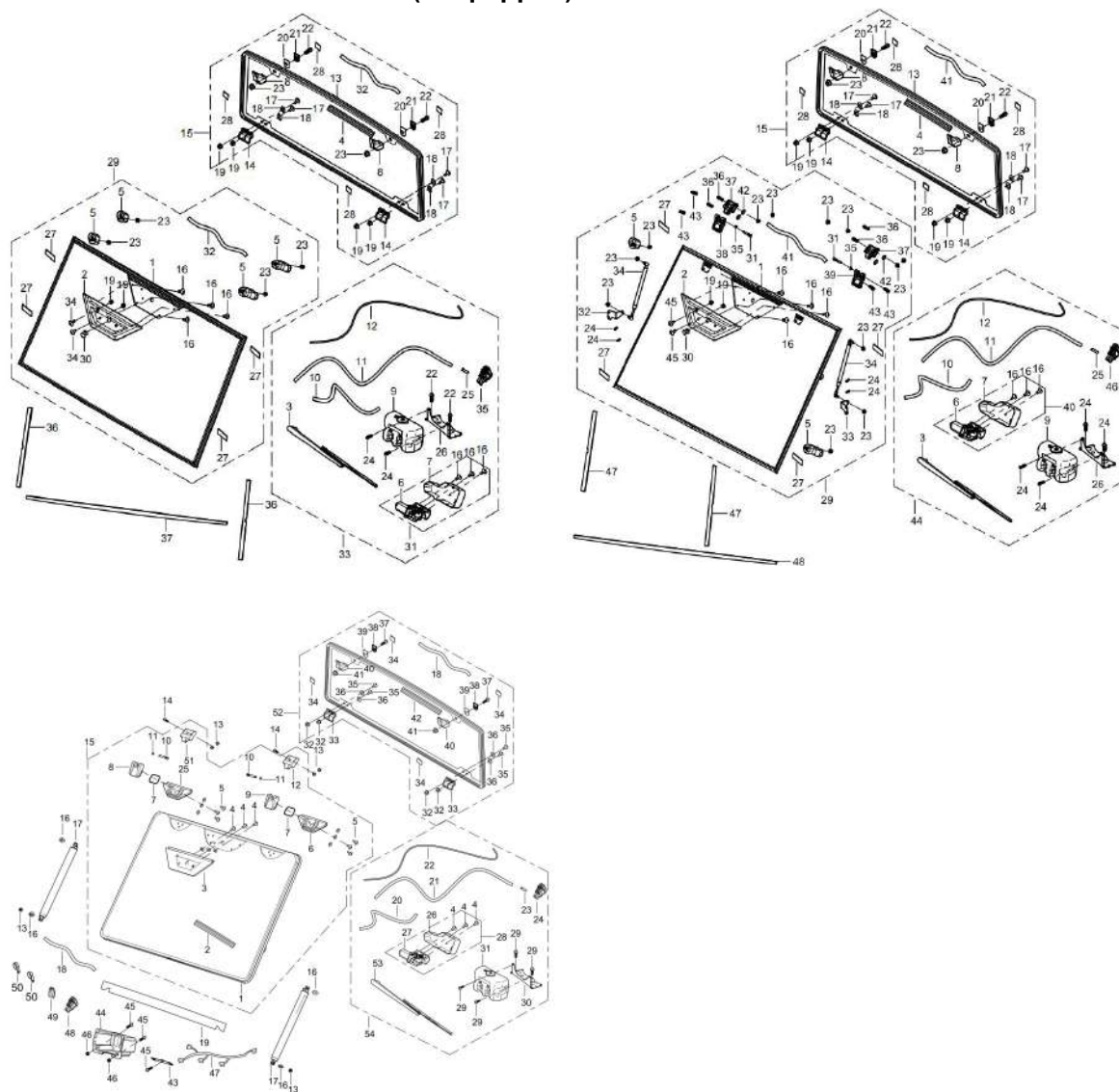

Rear Windshield Dismantling

Turn the rear windshield installation clip anticlockwise 90°. Remove the rear windshield from rear canopy rod. Remove inner mirror.

Loosen M6 screws, then remove motor cover and wiper motor.

Remove wiper arm. Loosen M6 screws and nuts, then remove wiper motor fixed mount.

Front windshield without gas spring

Turn the front windshield installation clip anticlockwise 90°. Remove the front windshield from roll bar.

Front windshield with gas spring

Loosen M8 nuts, then remove front windshield gas spring.

Loosen M8 bolts, remove front windshield hinge.

Turn the front windshield installation clip anticlockwise 90°. Remove the front windshield from roll bar.

Remove front panel, loosen M6 bolt and then remove glass water jug.

Front windshield with electric lift

Disconnect glass water pipe and windshield wiper motor connector wire, windshield electric lift wires.

Unscrew ball pin and M8 nut, then remove front windshield electric lift.

Loosen M8 bolts, remove front windshield hinge.

Remove the front windshield from roll bar.

Loosen M6 screws and nuts, remove front windshield electric lift switch box.

Inspection

After prolonged use, the debris flying in the air will cause some damage to the windshield. If the following conditions occur, please replace it immediately.

1. Unclear windshield affects driving.
2. The windshield installation clip is worn and cracked.

Tightening torque of M6 bolts: 9~12Nm.

Tightening torque of M8 bolts: 22~30Nm.

10.9 HALF-WINDSHIELD (If equipped)

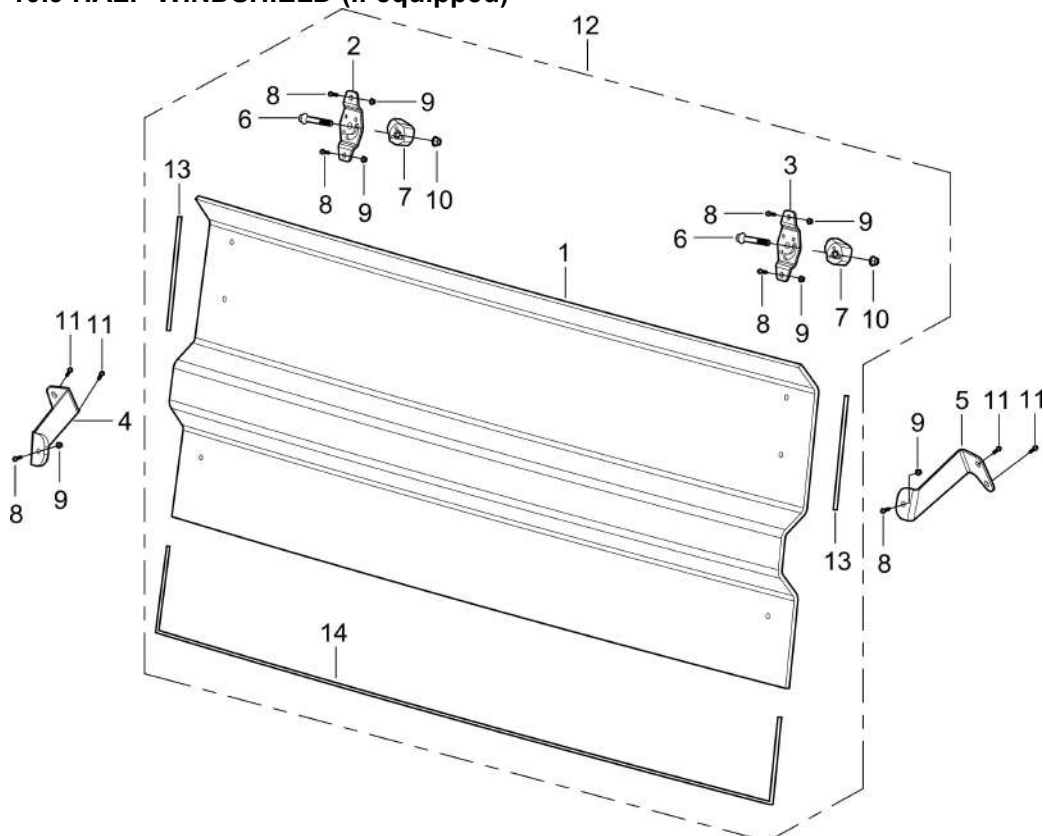

1. Half-Windshield	2. Half-Windshield Upper Mounting Plate (RH)	3. Half-Windshield Upper Mounting Plate (LH)	4. Half-Windshield Lower Mounting Plate (RH)	5. Half-Windshield Lower Mounting Plate (LH)
6. M8 Bolt	7. Installation Clip	8. M6 Bolt	9. M6 Locking Nut	10. M8 Locking Nut
11. M6 Bolt	12. Half-Windshield	13. Weather strip	14. Weather strip	

Dismantling

1. Turn the front windshield anticlockwise 90°.
2. Loosen M6 bolts and nut, then remove half-windshield from lower mounting plate.
3. Loosen M8 bolts and nut, then remove installation clip from upper mounting plate.
4. Loosen M6 bolts and nut, then remove upper mounting plate from half-windshield.

Inspection

After prolonged use, the debris flying in the air will cause some damage to the windshield. If the following conditions occur, please replace it immediately.

1. Unclear windshield affects driving.
2. The windshield installation clip is worn and cracked.

Tightening torque of M6 bolts: 9~12Nm.

Tightening torque of M8 bolts: 22~30Nm.

10.10 FRONT DOOR

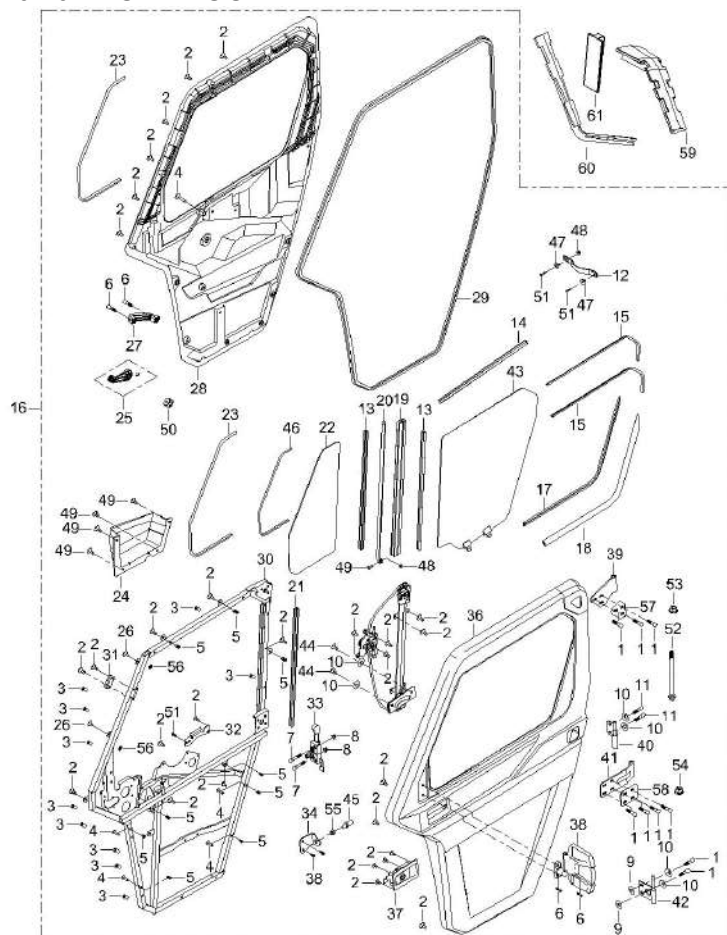
**Dismantling**

Loosen M6 screws and nuts, remove inner bushing and door trim.

Loosen M8 bolts and washer, remove the upper and lower hinge. Remove the front door from frame.

Remove door seal strip.

Loosen M8 screws, then remove rear view mirror.

Loosen M6 screws, remove door storage box.

Loosen M6 screws, remove handle.

Loosen M8 bolts and M12 nut, remove front impact mounting plate.

Remove door glass regulator rubber sleeve and handle.

Loosen M6 screw, separate the front inner door and frame.

Loosen M6 screw, remove door handles with keys.

Remove M6 screws, M6 plate nut, ST4.2 screw and washer, remove front outer door from frame.

Loosen M8 bolts and nut, remove front door lock.

Remove M6 screws, then remove glass upper and lower fixing plate.

Remove M6 screw and nut, then remove glass guide rail, front door power window glass and front secondary window glass from front door frame. Remove the door window glass seal.

Remove M6 screws then remove window regulator from front door frame.

Remove M6 screws, washer and clamp, then remove front door power window glass.

Remove M6 screw and nut, then remove glass guide rail.

The removal of rear door (double row) refers to front door.

Inspection

Check for the following conditions, if damaged, please replace it with a new one in time

1. Is there any crack or distortion on the front door window glass.

2. Whether the splines in the window regulator is damaged and cracks.

Tightening torque of M6 bolts:9~12Nm.

Tightening torque of M8 bolts:22~30Nm.

Tightening torque of M12 bolts:78~104Nm.

10.11 HALF DOOR (If equipped)

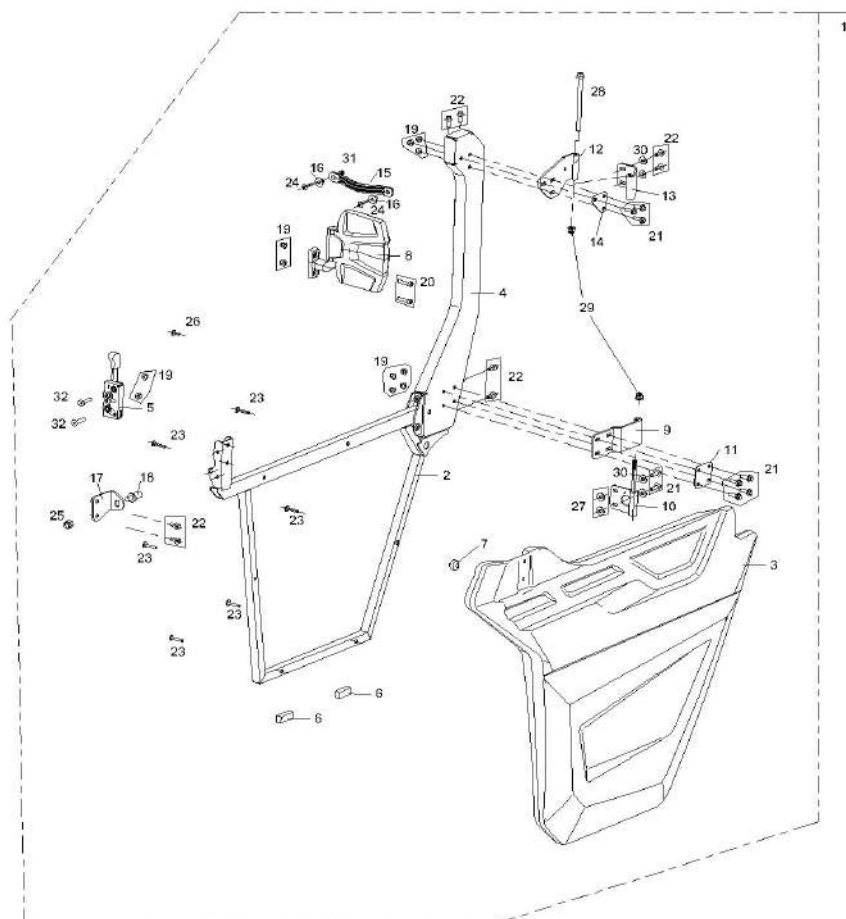

1. Front Half Door Assembly	2. Front Half Door Bracket	3. Front Half Door	4. Half Door Upper Fixed Bracket
5. Half Door Lock	6. Cushion Rubber	7. Rubber	8. Rear View Mirror
9. Half Door Lower Hinge	10. Door Static Hinge	11. Washer	12. Dynamic Hinge Mounting plate
13. Door Static Hinge	14. Washer	15. Door Trim	16. Bushing
17. Front Impact Mounting Plate	18. Door Striker	19. M8 Nut	20. M8 Screw
21. M8 Bolt	22. M8 Bolt	23. M6 Screw	24. M6 Screw
25. M12 Nut	26. M6 Screw	27. Washer	28. M10 Bolt
29. M10 Nut	30. Washer	31. M6 Nut	32. M8 Screw

Dismantling

1. Loose M8 screws and nuts, then remove rear view mirror from door.
 2. Loosen M6 screw and nut, then remove door trim.
 3. Loose M8 bolts and washers, then remove the half door hinge.
 4. Remove the half door from the roll bar.
 5. Loose M12 nut, then remove door striker. Remove M8 bolts and front impact mounting plate.
 6. Loose M6 screws, then remove front half door from front half door bracket.
- The removal of rear half door (double row) refers to front half door.

Inspection

Check for the following conditions, if damaged, please replace it with a new one in time

1. Is there any crack or distortion on the rotating shaft of the half door hinge.
2. Whether the locking mechanism in the half door lock is damaged and the torsion spring is damaged, etc.
3. Is there a crack in the half door and there is a gap in a large area of damage.

Tightening torque of M6 bolts:9~12Nm.

Tightening torque of M8 bolts:22~30Nm.

Tightening torque of M12 bolts:78~104Nm.

10.12 ROOF

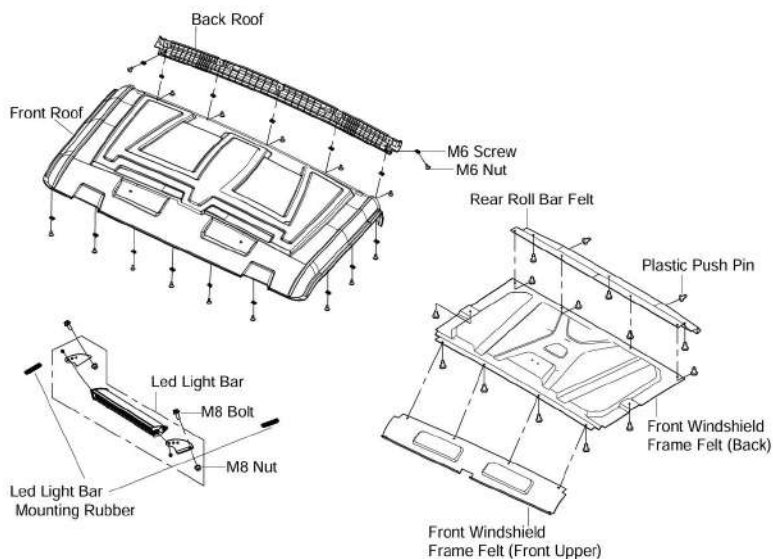

Dismantling

Remove M8 bolts and nuts and then remove leg light bar.

Remove 10 plastic push pins and then remove front windshield frame felt(back).

Remove plastic push pins and then remove front windshield frame felt (front upper).

Remove 5 plastic push pins and then remove rear roll bar felt.

Remove M6 screws and plate nuts, then remove front roof.

Remove M6 screws and plate nuts, then remove back roof.

Inspection

Check whether frame felt, roof and leg light bar cracks, damage, etc., please replace it in time.

Tightening torque of M8 bolts for leg light bar: 22~30Nm.

Tightening torque of M6 bolts for roof: 9~12Nm.

10.13 ROLL BAR and INNER MIRROR

Inner Mirror Dismantling

Loosen M6 nuts and screws, then remove inner mirror from mounting plate.

Loosen M6 nuts and screws, then remove inner mirror mounting plate from front windshield frame connection plate.

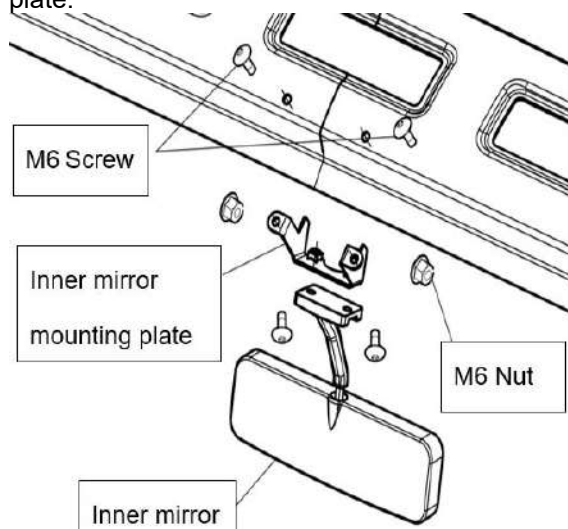

Roll Bar Dismantling

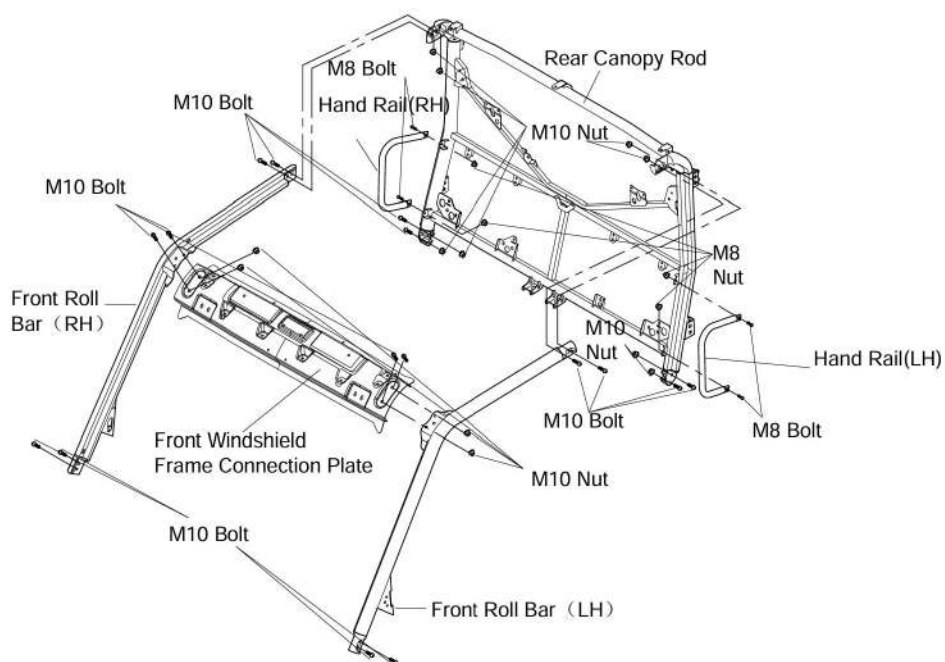

Loosen M10 bolts and nut, then remove front windshield frame connection plate.

Loosen M10 bolts, then remove RH and LH front roll bars.

Loosen M8 bolts and nut, then remove hand rail.

Loosen M10 bolts and nut, then remove rear canopy rod.

Inspection

Check inner mirror, hand rail and roll bar for cracks, damage, etc., please replace it in time.

Tightening torque of M6 bolts for inner mirror: 9~12Nm.

Tightening torque of M8 bolts for hand rail: 22~30Nm.

Tightening torque of M10 bolts for roll bar: 65~78Nm.

10.14 HEATING SYSTEM (For HV Version)

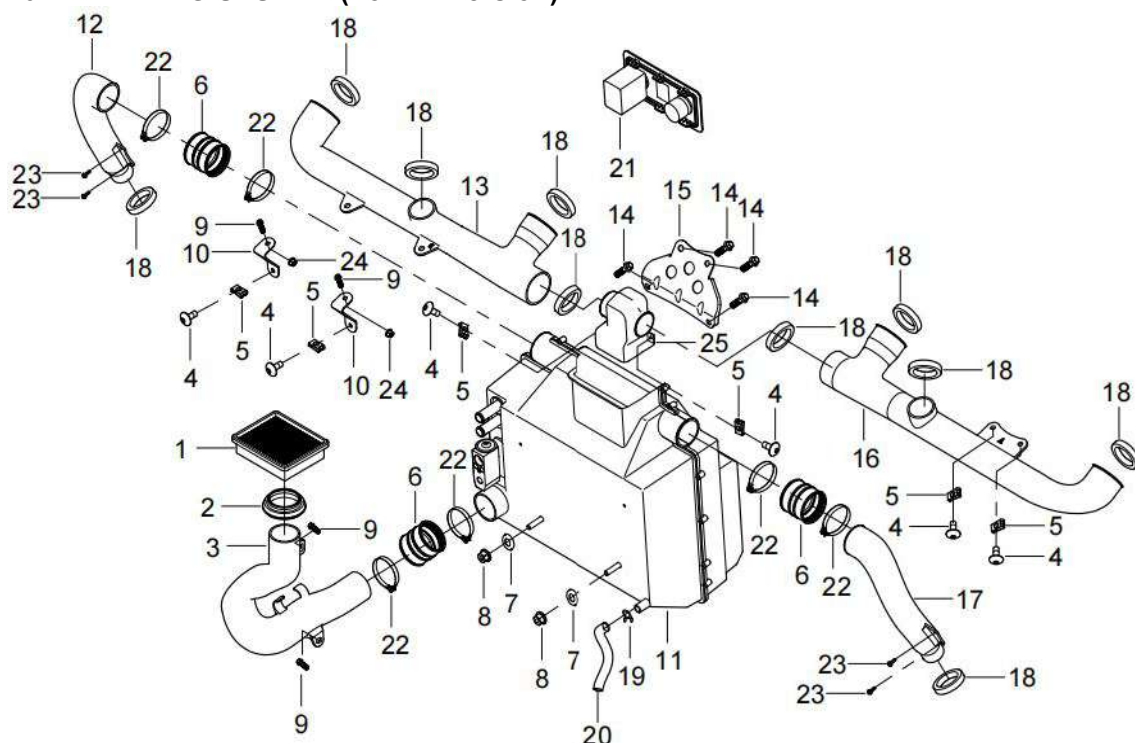

1.External Circulation Filter	2. A/C Connection Rubber Sleeve	3. A/C Inlet Duct	4. M6 Screw	5. Plate Nut M6
6. A/C Connection Rubber Sleeve	7. Washer	8. M8 Nut	9. M6 Bolt	10.A/C Outlet Duct Mounting Plate
11. Heater Box Assembly	12. Air Conditioning Vent Duct D	13.Air Conditioning Vent Duct E	14. M8 Bolt	15. Evaporator Fixing Plate
16.Air Conditioning Vent Duct A	17.Air Conditioning Vent Duct C	18. Pipe Seal Foam	19. Clamp	20.Drain pipe
21. Warm air switch	22. Clamp	23. ST3.5 Screw	24. M6 Nut	25.Duct Tee

Remove front panel. Remove external circulation filter.

Remove dash board.

Loosen M6 bolts and clamp, then remove A/C inlet duct and connection rubber sleeve.

Loosen ST3.5 screws and clamps, then remove A/C conditioning vent duct C and D.

Loosen the M6 screw, M6 plate nuts, remove pipe seal foam, A/C conditioning vent duct A and E.

Remove air conditioning duct tee from heater box.

Remove clamp, then remove drain pipe.

Loosen M8 bolts then remove heater box from mounting plate.

10.15 SNOW SHOVEL (If equipped)

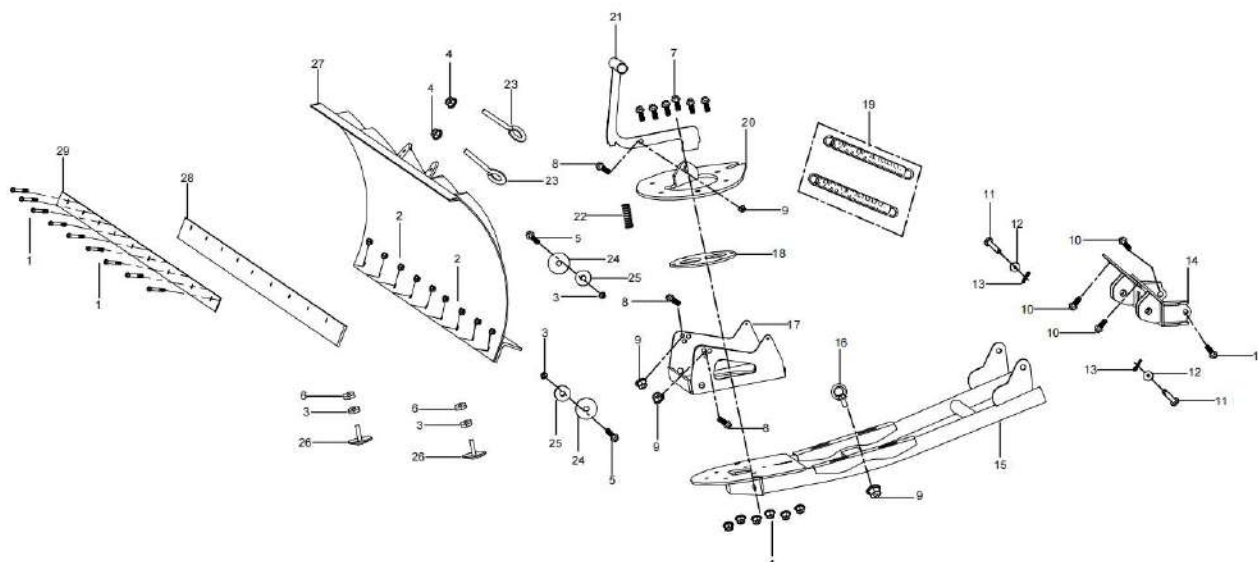

1. M10 Bolt	2. M10 Locking Nut	3. M12 Nut	4. M12 Screw	5. M12 Locking Nut
6. M12 Locking Nut	7. M8 Bolt	8. M10 Bolt	9. M10 Locking Nut	10. M10 Bolt
11. Snow Shovel Fixing Pin	12. Washer	13.R Pin	14. Snow Shovel Bracket Assembly	15. Snow Shovel Connecting Arm
16. Snow Shovel Hook Pin	17.Adjustment Bracket	18. Steering Plate	19. Tension Spring	20.Broad Bracket
21. Adjustment Lever	22. Adjustment Lever Spring	23. Tension Spring Hook	24. Washer	25.Washer
26. Hight Adjustment Screw	27. Tension Spring Ejector Plate	28.Sweep Snow Strip	29. Sweep Snow Strip Fixing Strip	

Dismantling

- 1.Loosen M10 bolts, then remove snow shovel from vehicle.
- 2.Remove M12 screw, tension spring hook and tension spring. Remove M12 screws, nuts and washer, then remove snow shovel from mounting bracket.
- 3.Remove M8 bolts, M10 bolt and nut, then remove adjustment lever, broad bracket and steering plate from adjustment plate.
- 4.Remove M12 screw, remove adjustment bracket from snow shovel connecting arm.
- 5.Remove snow shovel fixing pin, washer and R pin, remove snow shovel bracket assembly from connecting arm.

Inspection

Check spring for cracks, damage, etc., please replace it in time.

Tightening torque of M10 bolts:65~78Nm.

Tightening torque of M12 bolts: 78~104Nm.

11.HVAC SYSTEM

AC System	11-2	Compressor.....	11-3
Generator.....	11-3	Condenser.....	11-4
Evaporator.....	11-4	TXV.....	11-5
A/C Hose.....	11-5	Refrigerant discharge and filling.....	11-5
Air Supply System.....	11-7	Windshield Air Vent.....	11-7
Console Air Vent.....	11-7	Rear Row Air Vent.....	11-7
Air ducts.....	11-8	Blower.....	11-8
Blower speed switch.....	11-9	Control System.....	11-10
HVAC and temperature switches.....	11-11	NTC.....	11-12

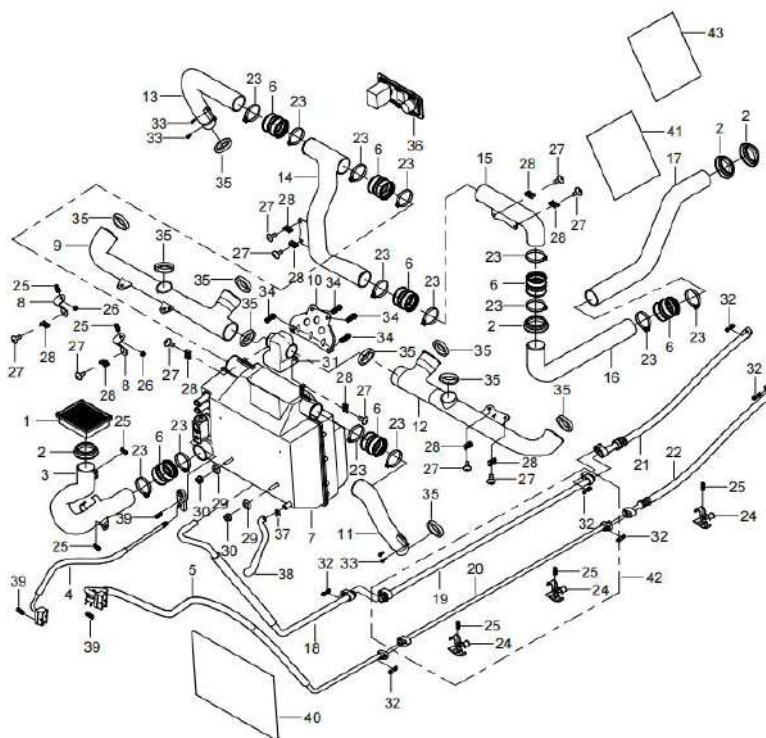

1.External Circulation Filter	2. A/C Connection Rubber Sleeve	3. A/C Inlet Duct	4.Cold-Evaporator Pipe	5.Cold-pressure Front Pipe
6. A/C Connection Rubber Sleeve	7. Evaporator	8. Outlet Duct Mounting Plate	9. A/C Outlet Duct B	10. Evaporator Fixing Plate
11. A/C Outlet Duct C	12. A/C Outlet Duct A	13. A/C Outlet Duct D	14.A/C Outlet Duct E	15. A/C Outlet Duct F
16. A/C Outlet Duct G	17. A/C Outlet Duct H	18.Steam-pressure Front Pipe	19.Steam-pressure Middle Pipe	20.Cold-pressure Middle Pipe
21.Steam-Pressure Rear Pipe	22.Cold-pressure rear Pipe	23. Clamp	24. Clamp	25. M6 Bolt
26.Locking Nut M6	27. M6 Screw	28. Plate Nut M6	29. Washer	30. Locking Nut M8
31. Duct Tee	32. M6 Bolt	33. ST3.5 Screw	34. M8 Bolt	35. Pipe Seal Foam
36.A/C Control switch	37. Clamp	38. Drain pipe	39. M6 Bolt	40. Evaporator Heat Shield
41. A/C Outlet Duct G Heat Shield	42.H/L Pressure Pipe	43. A/C Outlet Duct H Heat Shield		

The basic components of HVAC system are: AC system, heating system, air supply system and control system.

11.1 AC System

AC system consists of: compressor, condenser, evaporator, TXV, blower, pipe, electrical components.

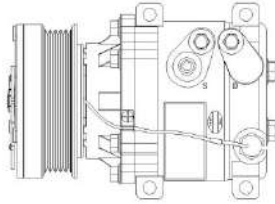
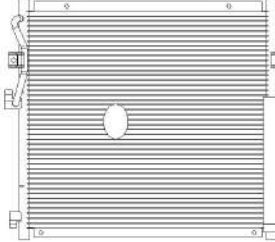
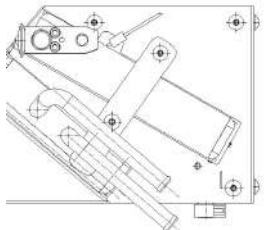
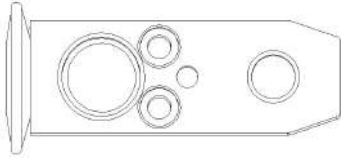
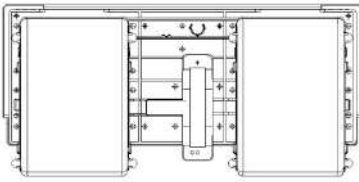
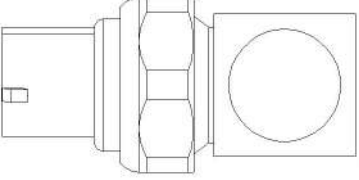
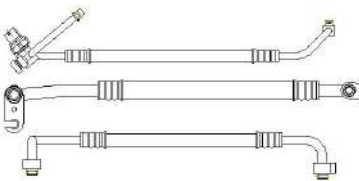
PARTS	Sketch Map	Function
Compressor		Compress the refrigerant and circulate it in the system
Condenser		The gaseous refrigerant discharged from the compressor is cooled to make it into liquid refrigerant
Evaporator		The refrigerant expands and absorbs heat from the air
TXV		Throttling and depressurization
Blower		Blow the hot air to the evaporator, and blow out the cool air from each air outlet
Pressure switch		When the pressure of the AC system is too high or too low, the AC system will stop working, protect the pipe or stop the compressor
A/C Hose		Refrigerant circulation pipe

The compressor is driven by the engine, and the refrigerant is sucked in from the evaporator and compressed to increase its pressure, and then sent to the condenser through the high-pressure hose.

The condenser is installed in front of the radiator. The refrigerant is cooled by the cooling fan of the engine and the ventilation of the car, and becomes liquid.

After the refrigerant gives off heat, it is filtered and drained by the drying filter.

The liquid refrigerant is pressed to the expansion valve under high pressure. Due to the limited flow function of the expansion valve, the refrigerant flow can be automatically adjusted according to the heat load in the vehicle compartment, so that the liquid refrigerant enters the evaporator after the limit.

When the refrigerant suddenly enters the evaporator with large capacity, the pressure drops due to the volume increasing, and then changes from liquid state to gas state. At the same time, it absorbs a large amount of heat to cool the air flowing through the evaporator, and then the air is sent into the cabin by the blower to reduce the temperature in the cabin.

The gaseous refrigerant with heat is sucked into the compressor to start the next cycle.

11.2 Compressor

Compressor is the heart of the AC system. It is driven by the engine to compress the low-temperature and low-pressure refrigeration steam into high-temperature and high-pressure steam. Through the compression work of the compressor, the heat of the low-temperature heat source is transferred to the high-temperature heat source, and the heat is transferred to the environment; at the same time, it also provides power for the refrigerant cycle of the refrigeration system.

Removal

- 1.Tilt cargo box.
- 2.Remove M6 bolts, then remove the belt cover and tension belt.
- 3.Remove M6 bolts, then remove rear pipes from compressor.
- 4.Disconnect compressor wires.
- 5.Loosen M8 bolts, then remove compressor from bracket.

Inspection and adjustment of belt

- 1.Tilt cargo box.
- 2.Remove the screw and remove the belt cover.
- 3.Use professional tooling adjust the belt tightness.
- 4.If the belt tightness is not within the range, loosen 4 bolts first, then adjust the belt tightness or change the belt.

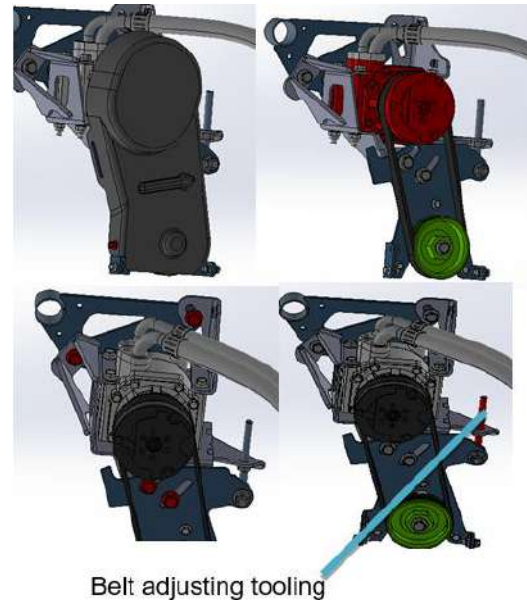

Belt tightness	TOOL
Belt deflection: 9-12mm(100N)	

- 5.Reassembly is the reverse of removal.

NOTE: If the belt needs to be replaced, please follow the specified specifications and models.

Belt size	EL (mm)
5pk670 (GATES)	670±5

NOTICE: Turn off the ignition key and shift the gear to P position. Pay attention to the exhaust pipe to avoid scalding.

Tightening torque of M6 bolts for belt cover:9~12Nm.

Tightening torque of M8 bolts for compressor: 22~30Nm.

11.3 Generator

The function of the generator is to transmit the power of the engine to the compressor through the pulley. When refrigeration, the coil of generator is electrified to generate magnetic force, and the clutch armature is closed to drive

the compressor spindle to run. After cooling, cut off the coil power supply, the magnetic force disappears, the pulley rotates over the bearing, and the compressor stops running.

Removal

- 1.Tilt cargo box
- 2.Remove M6 bolts, then remove the belt cover and tension belt.
- 3.Disconnect generator wire.
- 4.Remove M6 bolt and nut, M10 bolt and tension sleeve. Then remove generator from bracket.

Inspection

Parameters of generator	
Rated voltage	DC12V
Minimum pull-in voltage	DC9V
Breakaway torque	≥23NM
Rated power	48W (4A)
Maximum speed	10000rpm
Groove type	5PK

REQUIRED TOOL	
UNIT 115 MULTIMETER	

Unplug the connector of generator and measure the resistance between terminal and ground. Set the multimeter to 20Ω.

TEST probes	Resistance
Terminal and ground	3±0.5Ω

If the resistance is not within the range, the generator needs to be repaired or replaced.

Tightening torque of M6 bolts for belt cover:9~12Nm.

Tightening torque of M10 bolts for generator: 65~78Nm.

11.4 Condenser

The condenser is a kind of heat exchanger. The function of the condenser is to distribute the heat of the high temperature and high-pressure refrigerant gas discharged from the compressor to the air outside the vehicle through the tube wall and fins of the condenser. The refrigerant gas flows in the pipeline and gradually condenses into refrigerant liquid.

Removal

- Remove front bumper and winch.
- Remove front headlight cover.

-Remove M6 bolts, then remove pipes.

The upper pipe is condenser-compressor pipe, and the lower one is condenser-evaporator pipe.

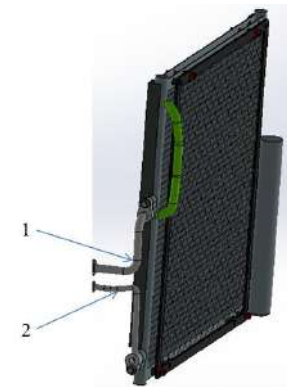

1. Condenser-compressor pipe

2. Condenser-evaporator pipe

NOTE: If you need to remove the pipe, please refer to the refrigerant discharge and filling first.

-Loosen M6 bolts, then remove condenser from radiator.

Inspections

Check condenser fins for clogging or damage. If damaged, replace a new one in time.

Remove insects, mud or other obstructions with compressed air or low-pressure water.

Installation

For installation, reverse the removal procedure.

Tightening torque of M6 bolts for condenser:9~12Nm.

11.5 Evaporator

The evaporator is also a kind of heat exchanger, but opposite to the condenser, its function is to vaporize the low-temperature and low-pressure refrigerant liquid after throttling, absorb a lot of heat in the air in the car, so as to cool the air in the car.

Removing the evaporator

Remove front panel. Remove external circulation filter.

Remove dash board.

Loosen M6 bolts and clamp, then remove A/C inlet duct and connection rubber sleeve.

Loosen ST3.5 screws and clamps, then remove A/C conditioning vent duct C and D.

Loosen the M6 screw, M6 plate nuts, remove pipe seal foam, A/C conditioning vent duct A and E.

Remove air conditioning duct tee from heater box.

Remove clamp, then remove drain pipe.

Remove M6 bolt, nuts and washers, then remove cold-evaporator pipe and steam-pressure front pipe.

Loosen M8 bolts then remove evaporator from mounting plate.

Installing the evaporator

The installation is the reverse of the removal procedure.

NOTE: Also if you need to replace the evaporator, please refer to the **refrigerant discharge and filling first.**

11.6 TXV

- The high temperature and high-pressure refrigerant liquid is changed into low temperature and low-pressure refrigerant liquid by throttling and depressurizing, and then sent to the evaporator for evaporation.

- Adjust the flow of refrigerant according to the change of refrigeration load, so as to keep the temperature in the car stable and the refrigerant working normally.

- Control refrigerant flow to prevent liquid hammer and abnormal overheating.

NOTE: The TXV and evaporator are an assembly. If the TXV is broken, the whole assembly needs to be replaced.

11.7 A/C Hose

The hose needs to be replaced in case of leakage, wear and aging.

NOTE: If replace the hose, the refrigerant should be drained first, Refer to the **refrigerant discharge and filling.**

11.8 Refrigerant discharge and filling

REQUIRED TOOLS	
Manifold Pressure Gage	
AUTO refrigerant changer	

Refrigerant discharge

When the refrigeration accessories need to be replaced, the refrigerant must be drained first. The following is operated by the manifold pressure gauge.

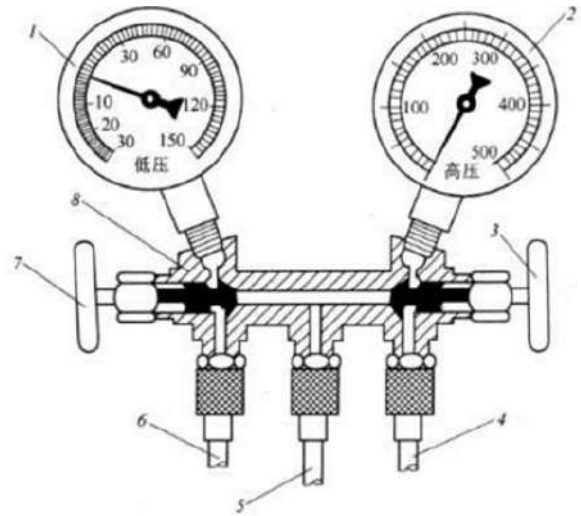

- 1.Low meter(blue)
- 2.High meter(red)
- 3.High pressure manual valve(red)
- 4.High pressure hose(red)
- 5.Service hose (yellow or green)
- 6.Low pressure hose(blue)
- 7.Low pressure manual valve(blue)

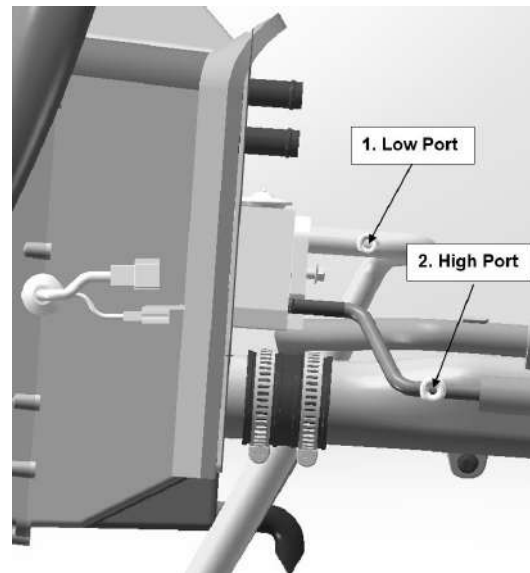

1.Close the high and low manual valves of the meter valve first, connect the pipeline, and pay attention to the connection method of high-pressure pipe and low-pressure pipe.

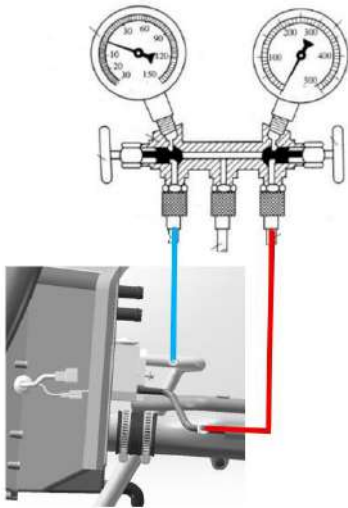

2. Slowly open the low-pressure manual valve and slowly drain the refrigerant. A small amount of refrigerant flowing out of the refrigerant should be collected by an oil collector.
3. When the pressure of the low-pressure gauge drops to 345kpa, slowly open the high-pressure manual valve, and pay attention not to open too much. If there is more refrigerant oil flowing out at this time, it means that the discharge speed is too fast, and the high- and low-pressure manual valves should be adjusted down.
4. When the pressure gauge drops to 0, it means that the discharge is finished. At this time, the valve on the gauge valve should be closed.
5. Measure the collected frozen lubricating oil. If the oil quantity exceeds 15g, add the same amount of new frozen lubricating oil.

NOTE: Do not mix different brands of oil.

Leak detection of the system

Connect the hose to the high and low pressure interfaces correctly, connect the maintenance hose to the pressure equipment, open the high and low pressure valves, and fill the system with dry nitrogen (or dry compressed air) with the pressure of about 1.8MPa. Then stop inflation, close the high and low pressure valve valves, and coat the joints of the system with soap water for leakage detection. After holding for 20 minutes, the pressure did not change significantly.

Vacuum system

Connect the hose, connect the maintenance connector to the vacuum pump, open the high and low pressure valves, maintenance hose valve and start the vacuum pump. The vacuum time should not be less than 20 minutes. If the automatic filling

machine is used, the vacuum degree should reach 99.1kpa.

Refrigerant filling

After the vacuum is qualified, close the high and low pressure valves at the same time, connect the Yellow pipeline to the bottle opener, and then screw the bottle opener into refrigerant R134a, rotate the bottle opener to pierce the refrigerant bottle, and then rotate the bottle opener to release the refrigerant. (at this time, the red and blue switches of the high and low pressure meters are all closed), the air in the maintenance pipeline can be discharged, and the refrigerant can be seen to be ejected.

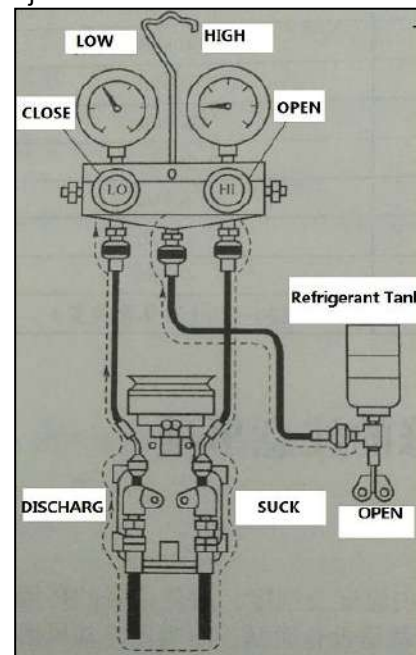

High port filling

Turn on the high-pressure filling cap (Mark "H"), and fill with high-pressure. At this time, the refrigerant is added into the system as a liquid (refrigerant bottle is inverted), and a bottle (220g) is added. In this process, it is forbidden to start the air conditioning system.

After filling, close the high-pressure filling knob.

Low port filling

Take off the bottle opener slowly to prevent frostbite caused by the rapid ejection of residual refrigerant. Replace the new refrigerant bottle, repeat the above refrigerant opening and exhaust process, turn on the low-pressure filling cap (Mark "L"), and keep the high pressure cap (Mark "H") closed. At this time, the refrigerant is added into the system in gaseous state. Keep the refrigerant bottle upright, start the air conditioning system, and adjust the blower to the

maximum, maintain the idle state.

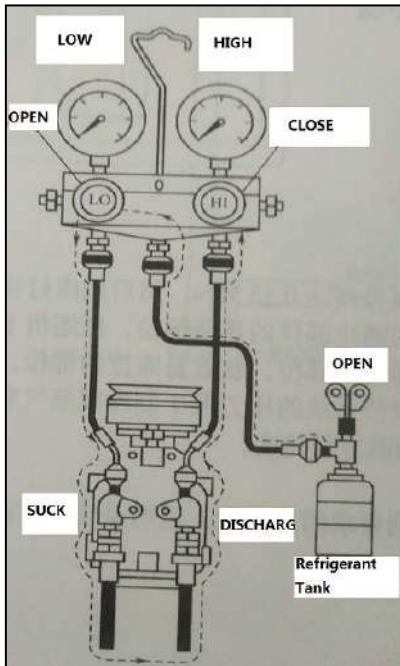

During the low-pressure filling process, when replacing the refrigerant bottle, turn off the low-pressure cap(Mark “L”) first, and repeat the yellow pipeline exhaust process.

Continue filling according to the low-pressure filling method, observe the sight glass on the condenser-evaporator hose, and the filling is completed when there is no obvious bubble. Turn off the engine, turn off the high and low pressure caps.

Pressure range	
Low meter	High meter
0.15-0.2MPa	1.2-1.5MPa

Test conditions: The temperature of the evaporator suction inlet is 30-35 °C, the engine speed is 2000rpm, the temperature switch is set to the maximum cooling gear, and the blower is at the max.

Remove the manifold pressure gauge, and tighten the interface cap.

11.9 Air Supply System

The air in the car is forced into the HVAC assembly by the blower, and then sent to the cabin after passing through the filter screen and ventilation pipe to realize the heating or cooling in the cabin.

11.10 Windshield Air Vent

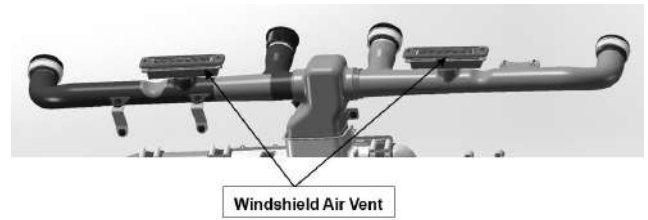

Removing the Air Vents

Loosen ST4.2 screws, then remove windshield air vent and supporting plate.

Inspection

Rotate the knob to check the air vent.

Installing the Air Vents

The installation is the reverse of the removal procedure.

11.11 Console Air Vent



Removing the Air Vents

The air vent is inlaid on the air outlet elbow and can be removed by gently prying with a flat head screwdriver.

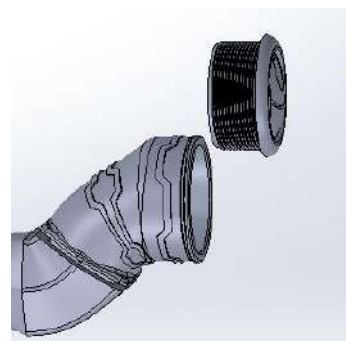

Inspection

Rotate the molded dot to check the air vent.

Installing the Air Vents

The installation is the reverse of the removal procedure.

11.12 Rear Row Air Vent



Removing the Air Vents

The rear air vent is inlaid on the air outlet elbow and can be removed by gently prying with a flat head screwdriver.

Inspection

Rotate the molded dot to check the air vent.

Installing the Air Vents

The installation is the reverse of the removal procedure.

11.13 Air ducts

Removing the Air Ducts

1. Remove the front headlight cover, front panel and front panel liner.
2. Loosen M6 bolts, nuts and clamps, then remove the air ducts from evaporator and AC duct tee.
3. Remove front transmission shaft shield, rear seat air vent. Loosen M6 bolts, nuts and clamps, then remove the rear seat air ducts.(Only for double rows version)

Inspection

Check the air ducts for crack or damaged. If damaged, replace one in time.

Installing the Air Ducts

The installation is the reverse of the removal procedure.

11.14 Blower

The blower assembly includes the blower resistor, the blower motor and the blower fans.

GENERAL

In the following procedures the dash board lower guard plate is removed for clarity.

Removing the blower

- 1.Remove the nuts.
- 2.Remove the evaporator cover and griller.
- 3.Remove pipes and evaporator.
- 4.Unplug the connectors.
- 5.Remove the screws, then remove the blower from mounting bracket

Installing the blower

The installation is the reverse of the removal procedure.

Testing the Blower Motor

Turn the vehicle key switch to ON.
Turn the blower speed switch to low, medium 1, medium 2, then high.

BLOWER TROUBLESHOOTING CHART		
Is blower working?	YES →	Everything is OK
NO↓		
Check ACPOWER connector	NO →	Refer to wiring diagram
YES↓		
Check blower fuse (15A). Is fuse burnt?	YES →	Replace fuse Is blower working?
NO↓		
Bypass blower speed switch		
↓		
Blower turns?	YES →	Replace blower speed switch Is blower working?
	NO →	Replace blower and motor assembly Is blower working?
NO↓		
Check wiring harness, connectors, and ground		
↓		
Harness and connectors good?	NO →	Repair or replace defective part(s)

Blower Motor resistor

The blower motor resistor provides electrical resistance in series to the blower motor. The fan speed control switch sends current to one blower resistor pin based on selected fan speed. Adding resistance to the circuit slows the blower motor. Removing resistance from the circuit speeds the blower motor.

Testing the Blower Motor Resistor

The blower motor resistor cannot be tested independently from the blower motor.
1. Turn the fan on to low, medium 1, medium 2, then high.

2. Read the voltage at the blower assembly connector for each speed.

If battery voltage is available at each pin of the blower assembly connector and the blower motor does not come on. Ensure there is a good ground. If all electrical tests are OK. Replace the blower assembly.

11.15 Blower speed switch

The blower speed switch sends current to one pin of the blower motor resistor depending on selected speed.

The blower speed switch also supply power to AC switch, so AC switch can control AC system.

Testing the Blower Speed Switch

1. Disconnect blower speed switch.
2. Ensure battery voltage is available at pin 1 and 5 (switch side).
3. Disconnect blower speed switch.
4. Test resistance as per following table.

REQUIRED TOOL	
UNIT 115 MULTIMETER	

Set the multimeter to "200 Ω"

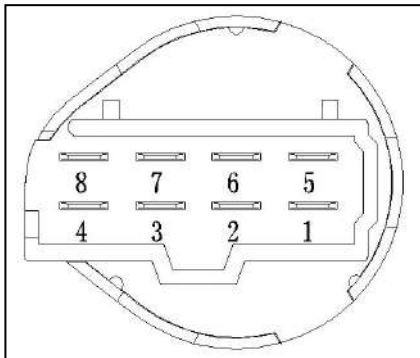

SPEED	PINS	SPECIFICATIO N
Off	1 and 8	O.L
	5 and any pin	O.L
Any speed	1 and 8	0 Ω
Low	5 and 3	0 Ω
Medium1	5 and 6	0 Ω
Medium2	5 and 2	0 Ω
High	5 and 7	0 Ω

Replace blower speed switch if test is not as per specifications.

11.16 Control System

The purpose of the control system is to make the air conditioning system work normally and maintain the required comfortable temperature and air supply conditions in the vehicle. There are a series of control elements and actuators in the air conditioning system.

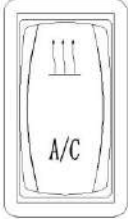
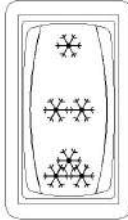
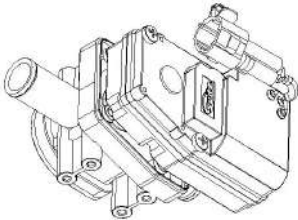
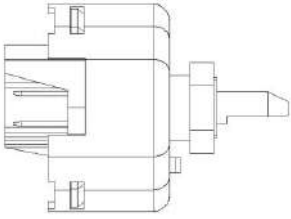
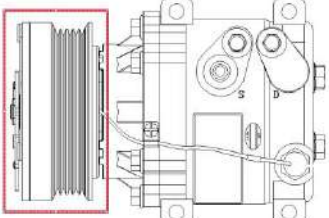
PARTS	Sketch Map	Function
HVAC switch		Control HVAC system heating or cooling
Temperature control switch		Adjust the evaporation temperature of evaporator surface
Electric valve		The heater control valve opens to allow coolant to pass through. When the coolant circulates, it heats up the unit.
Blower speed switch		Turn the blower to low, medium 1, medium 2 and high.
Compressor electromagnetic clutch		The power of the engine is transmitted to the compressor through the pulley

11.17 HVAC and temperature switches

Remove the switches refer to *electrical system switches*.

11.18 NTC



NTC is installed on the surface of evaporator.

Removing the NTC

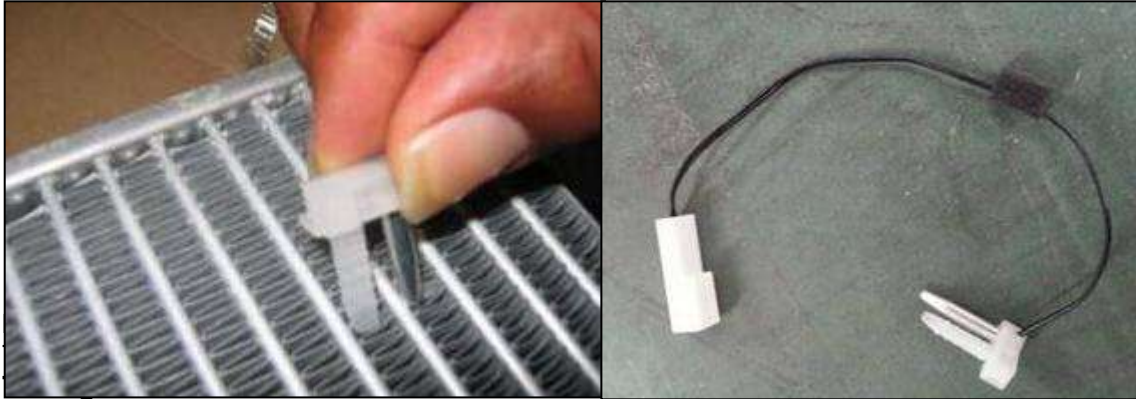
1. Remove the evaporator refer to the *EVAPORATOR*.
2. Remove the NTC.



REQUIRED TOOL

REQUIRED TOOL			
UNIT 115 MULTIMETER		Thermostatic bath	

Set the multimeter to "20K Ω "

Put the NTC into the thermostatic bath, adjust the temperature and test the resistance of NTC as per following table.

Temperature ($^{\circ}\text{C}$)	Rmin (K Ω)	Rstandard (K Ω)	Rmax (K Ω)
-1	6.785	7.006	7.227
0	6.483	6.650	6.816
1	6.114	6.314	6.515
2	5.797	5.998	6.198
3	5.498	5.699	5.899
4	5.217	5.417	5.616
5	4.951	5.150	5.347
6	4.701	4.898	5.094
7	4.464	4.660	4.864
8	4.241	4.435	4.627
9	4.031	4.222	4.412

Replace the NTC if test is not as per specifications.

12. ELECTRICAL SYSTEM

Charging System..... 12-1	Starting System.....12-6
EFI System..... 12-9	Ignition System..... 12-11
Light System 12-15	Cooling System 12-16
Fuse..... 12-16	Relay.....12-16
Speedmeter System..... 12-17	Gear Position Indication Switch..... 12-17
Oil Pressure Sensor..... 12-17	2WD/4WD Switch..... 12-18
Rear Diff Lock Switch..... 12-18	Multifunction Gauge..... 12-18
12-Volt Auxiliary Power Outlet..... 12-21	12-Volt Power Outlet..... 12-21
Multifunction Switch..... 12-22	Winch..... 12-22
EPB Switch..... 12-23	EPS Controller..... 12-23

Overhauling information

Warning

Bulb will be very hot after turning on headlamp. Please do not touch it immediately after its off. In operation, bulb needs to be cooled.

In warning inspection of water temperature, fire or high temperature liquid may be needed, keep it far away from inflammables and do not to be burnt.

The temperature will be very high in turning of headlamp. For replacement, grease dirt will be splashed to glass in case of operation with bare hands or wearing dirty gloves. As a result, hot spots and glass deformation may be caused with damage to bulb as well.

Pay attention to the following in replacing bulb:

- Do not replace bulb when it is on. Turn off ignition switch and replace it after cooling bulb.
- In order to avoid splashing grease to glass, wear clean gloves in replacing bulb.
- Use cloth with alcohol or banana water to clean glass to prevent any grease sticking to glass.

Check battery to confirm whether it is normal.

Regularly check switch and do not dismantle it from vehicle in inspection.

Cables and wires of each part need to be arranged reasonably (refer to chapter 1). For dismantling and installation of tail lamp and rear steering lamp, please refer to chapter 4.

12.1 CHARGING SYSTEM

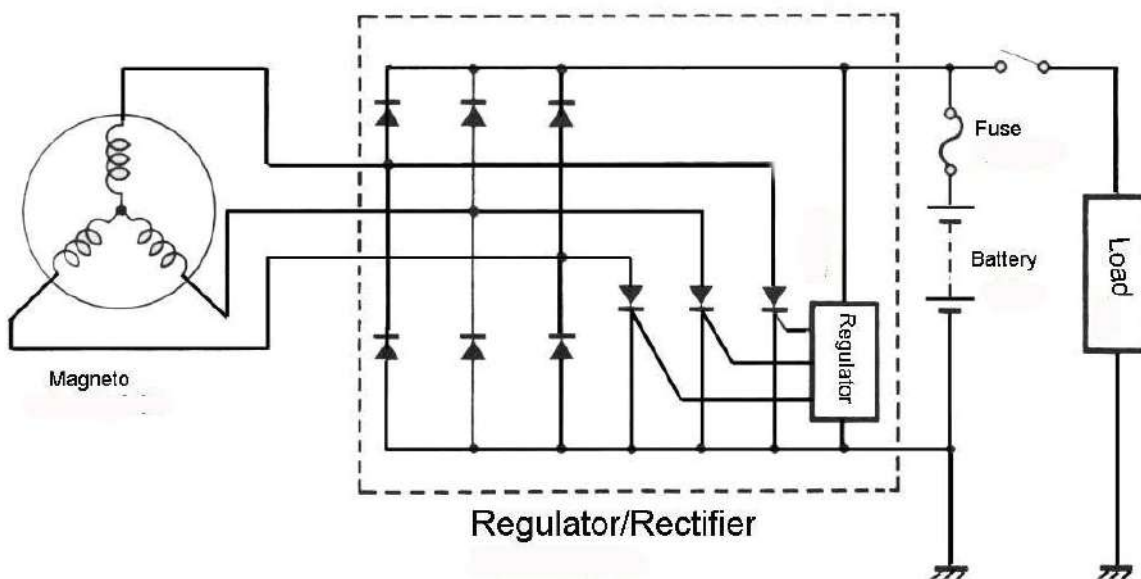

GENERAL

SYSTEM DESCRIPTION

The purpose of the charging system is to keep the battery at a full state of charge and to provide the electrical system with the required electrical power for normal vehicle operation.

Magneto

The magneto is the primary source of electrical energy. It transforms magnetic field into electric current (AC).

The magneto has a 3 phases series stator.

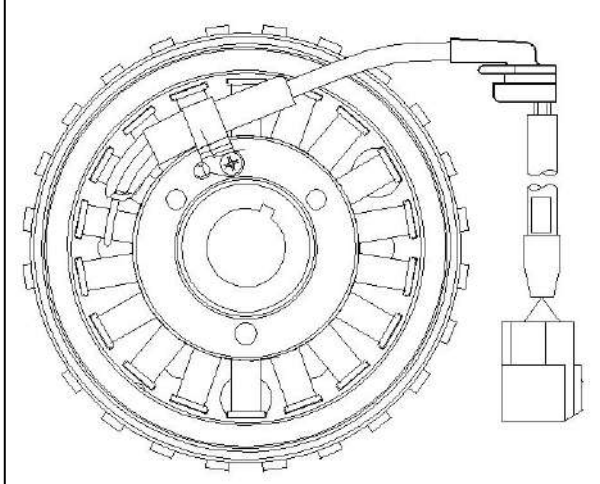

Voltage Regulator/Rectifier

The rectifier receives AC current from the magneto and transforms it into direct current (DC).

The voltage regulator, included in the same unit, limits voltage to prevent any damage to electrical components.

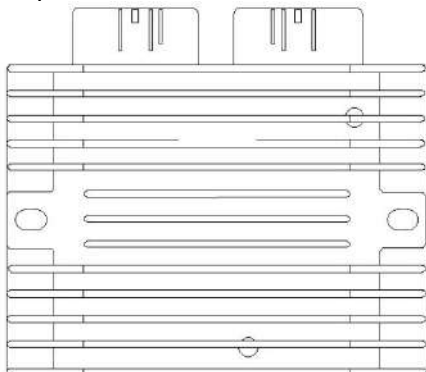

NOTE: If the battery will not stay charged, the probel can be any of the charging system components. If these all check good, try a new voltage regulator.

Battery

The battery supplies DC power to the electric starter for cranking the engine. During engine starting, it also supplies DC power to the entire electrical system.

At low engine RPM operation and high current load conditions, it supplements the magneto output and helps to maintain a steady system voltage.

INSPECTION

Testing Charging System Output

First ensure that battery is in good condition prior to performing the following tests.

Testing the Output Voltage with multimeter.

1. Start engine with the less consumption as possible (no lights, no accessories).
2. Increase engine RPM as specified in the following table and read voltage in the multimeter.

Output Voltage Test	
Engine Speed	Voltage (DC)
4000 RPM	14.5 ± 0.5V

If voltage is above specification, replace voltage regulator/rectifier.

If voltage is below specification, check stator output and wiring harness prior to concluding that voltage regulator/rectifier is defective.

Stator

Stator Connector Access

The stator is directly connected to the voltage regulator/rectifier.

Testing the Stator Continuity

1. Disconnect the stator connector from the voltage regulator/rectifier.
2. Check resistance between YELLOW wires.

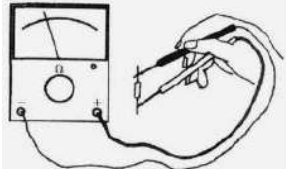
Required Tool	
MULTIMETER	
TERMINAL	RESISTANCE @ 20°C (68°F)
1 and 2	0.15 - 0.30 Ω
1 and 3	
2 and 3	

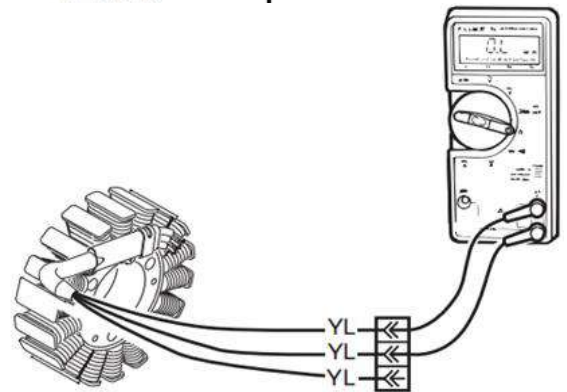

3. If any reading is out of specification, replace stator.

4. Re-plug connectors properly.

Testing the Stator Static Insulation

1. Disconnect the stator connector from the voltage regulator/rectifier.
2. Connect multimeter between any YELLOW wire (on stator connector) and engine ground.

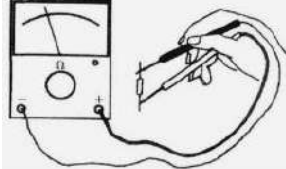
Required Tool	
MULTIMETER	
TEST PROBES	RESISTANCE @ 20°C (68°F)
Any YELLOW wire and engine ground	Infinite (open circuit)

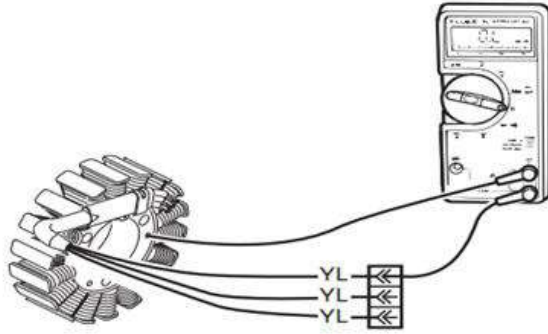

3. If there is a resistance or continuity, the stator coils and/or the wiring is shorted to ground and needs to be repaired or replaced.

4. Re-plug connectors properly.

Check Battery

1. Connect a battery load tester.
2. Ensure proper test conditions.

TEST CONDITIONS	
Initial battery voltage‡	Above 12.5 Vdc
Engine	OFF
Load	3 times the amp-hour (AH) rating
Time	15 seconds
‡ Required for accurate testing	

SPECIFICATION	
Battery	Above 9.6 Vdc

If battery voltage drops below specification during test, replace battery and perform a CHARGING SYSTEM LOAD TEST.

Charging System Load Test

1. Connect a battery load tester.
2. Start vehicle and read voltage on tester.

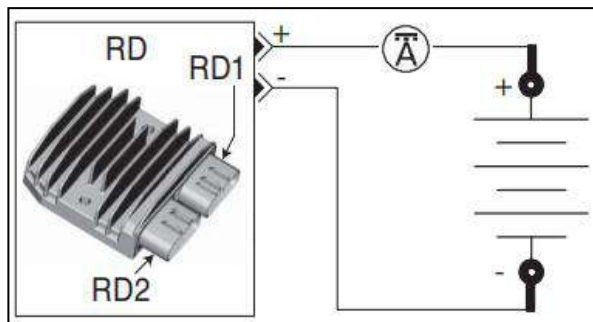

SPECIFICATION	
Voltage	12.5 - 15 Vdc

If voltage is above specification, replace regulator and continue CHARGING SYSTEM LOAD TEST.

3. Connect an ammeter around RD1-1 wire.



DC CURRENT TEST WITH INDUCTIVE AMMETER

1. Output connector of voltage regulator
2. Ammeter clamped over RED wire
4. Ensure proper test conditions.
5. Read amperage on ammeter.
45±5A

TEST CONDITIONS	
Battery voltage at idle‡	Above 12.6 Vdc
Engine	Increase to 4000 RPM
Load	As required to decrease battery voltage to 12 Vdc
Time	15 seconds
‡ Required for accurate testing	

NOTE: With a fully charged battery and no electrical loads, specification is less than 10A.

If amperage or voltage is not within specification, verify magneto and wires. Replace:

–Voltage regulator if magneto test is within specifications.

–Magneto if magneto test is not within specifications.

PROCEDURES

VOLTAGE REGULATOR

Removal

Tilt cargo box.

Disconnect the voltage regulator connector.

Loosen M6 bolts, remove voltage regulator.

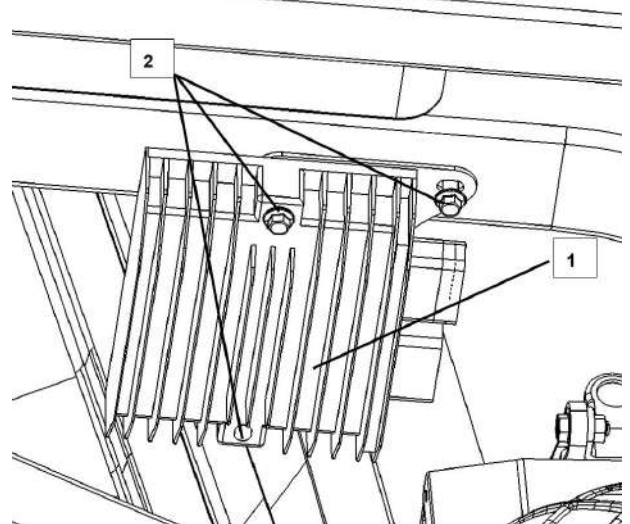

1. Voltage Regulator

2. M6 Bolts

Testing the Voltage Regulator Continuity

Due to internal circuitry, there is no static test available.

Voltage Regulator Wire Identification

FUNCTION	PIN	COLOR
12Vdc output	RD1-1	Red
12Vdc ground	RD1-2	Black

12Vac input	RD2-1	Yellow
12Vac input	RD2-2	Yellow
12Vac input	RD2-3	Yellow

Testing the Voltage Regulator Power

1. Check voltage at RD1-1.

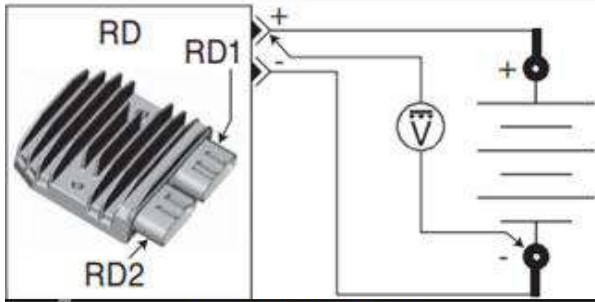

TEST CONDITIONS	
RD1-1	Hot at all times

BACKPROBE	PROBE	SPECIFICATION
RD1-1	BAT2 (-)	Battery voltage

2. Connect a battery load tester.
3. Start vehicle.
4. Ensure proper test conditions.

TEST CONDITIONS	
Battery voltage at idle‡	Above 12.6 Vdc
Engine	Increase to 4000 RPM
Load	As required to decrease battery voltage to 12 Vdc
Time	15 seconds

‡ Required for accurate testing

5. Measure voltage drop.

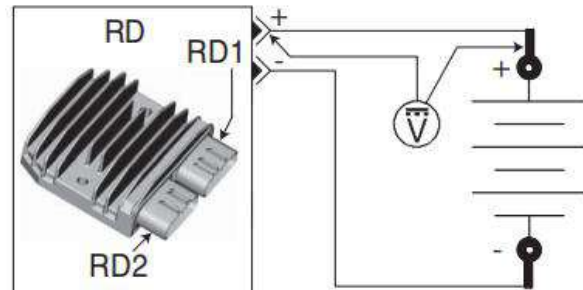

BACKPROBE	PROBE	SPECIFICATION
RD1-1	BAT1 (+)	Under 0.2 Vdc

If voltage drop is above specification, locate and repair damaged connector/wire.

Testing the Voltage Regulator Ground

1. Check ground at RD1-2.

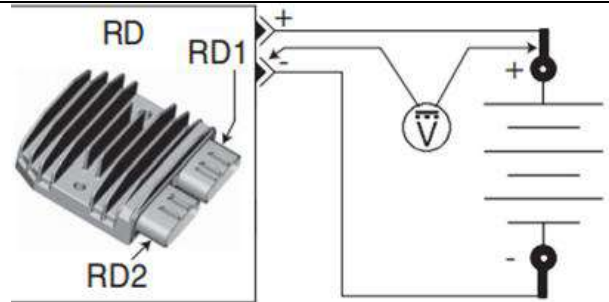

Test Conditions	
RD1-2	Permanent ground

Backprobe	Probe	Specification
RD1-2	Bat 1(+)	Battery voltage

2. Connect a battery load tester.
3. Start vehicle.
4. Ensure proper test conditions.

TEST CONDITIONS	
Battery voltage at idle‡	Above 12.6 Vdc
Engine	Increase to 4000 RPM
Load	As required to decrease battery voltage to 12 Vdc
Time	15 seconds

‡ Required for accurate testing

5. Measure voltage drop.

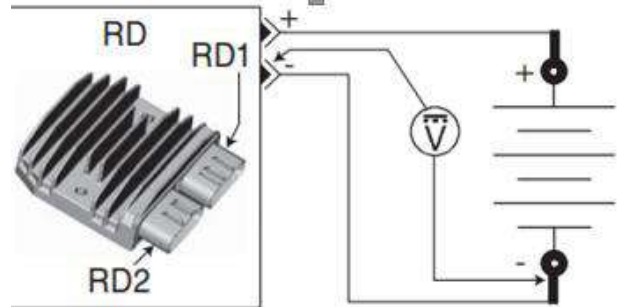

Backprobe	Probe	Specification
RD1-2	Bat 2(-)	Under 0.4 Vdc

If voltage drop is above specification, locate and repair damaged connector/wire.

Installation

Tighten M6 bolts for voltage regulator to torque: 9~12Nm.

BATTERY

The vehicle is equipped with a maintenance-free type battery. Refer to battery manufacturer's instructions for proper filling, activation and routine charging procedures.

Troubleshooting

Discharged or Weak Battery

1. Loose or corroded battery cable connections.
 - Tighten or repair battery cable connections.
2. Worn or defective battery.
 - Charge and test battery.
3. Defective magneto stator.
 - Test stator, refer to MAGNETO AND STARTER SYSTEM subsection.
4. Defective regulator/rectifier.
 - Test system voltage.
5. Damaged magneto rotor or Woodruff key.
 - Replace magneto rotor or Woodruff key, refer to

MAGNETO AND STARTER SYSTEM subsection.

Battery Removal

⚠WARNING

Always respect this order for removal; disconnect BLCAK (-) cable first. Electrolyte or fuel vapors can be present and spark may ignite them and possibly cause personal injuries.

The battery is located underneath the driver's seat.

Removing the Battery

1. Remove operator's seat.
2. Remove push pin and battery cover.
3. Remove fuse holder housing.
4. Disconnect BLACK (-) cable first, then the RED (+) cable.

NOTICE: Always respect this order for removal; disconnect BLACK (-) cable first.

5. Loosen M6 bolts, then remove battery fixed plate.
6. Remove battery.

Cleaning the Battery

Clean the battery rack, cables and battery posts using a solution of baking soda and water.

Remove corrosion (if so) from battery cable terminals and battery posts using a firm wire brush. Rinse with clear water and dry well.

Inspecting the Battery

Visually inspect battery casing for cracks or any other damages. If casing is damaged, replace battery and thoroughly clean battery support with a water and baking soda solution.

Inspect condition of battery posts, battery support, holding strap and strap attachment points and wire terminal lugs.

Battery Storage

It is not necessary to remove the battery during vehicle storage but it is recommended for long term storage.

If the battery is left in the vehicle during storage or used infrequently, disconnect the BLACK (-) negative battery cable to eliminate battery current drain from the electrical equipment.

Recharge the battery once a month with an approved battery charger as per manufacturer's recommendations.

Clean battery, battery support and connections as required.

For other recommendations during storage, refer to battery manufacturer instructions.

⚠WARNING

Ensure battery is stored in a safe place, out of reach for children.

Activating a New Battery

Refer to the instructions provided with the battery.

Charging a Battery

⚠WARNING

Always wear safety glasses and charge in a ventilated area. Never charge or boost a battery while it is installed on vehicle. Do not open the sealed cap during charging. Do not place battery near open flame.

NOTICE: If battery becomes hot, stop charging and allow it to cool before continuing.

NOTE: If battery pressure increases due to overcharging, the valve opens to release excess

pressure, preventing battery damage.

An automatic charger is a fast and convenient way for error-proof charging.

Always follow the battery manufacturer's charging instructions.

When using a constant current charger, charge battery according to the chart below.

Battery Voltage Below 12.8 V and Above 11.5V.

STANDARD CHARGING (RECOMMENDED)	
APPROXIMATE TIME	CHARGE
4 - 9 HOURS	2 A
QUICK CHARGING	
APPROXIMATE TIME	CHARGE
50 MINUTES	10 A

Installing the Battery

NOTICE: Always connect RED (+) cable first then BLACK (-) cable.

Tighten M6 bolts for battery fixed plate to torque: 9~12Nm.

GROUND

Ensure ground is clean and tight.

12.2 STARTING SYSTEM

GENERAL

System Description

The starting system is composed of an electric starter supplied in current by the battery through a solenoid.

The starter solenoid receives a 12 Vdc input from the ignition switch and the ground signal is provided by the Gear controller.

–Transmission in Park or Neutral position and/or brake pedal held.

–Ignition switch turns to the start position and hold until the engine starts.

Electrical Cables and Connections

Check all connections, cables and wires. Tighten any loosen connections. Replace any cracked wires/cables.

Engine Cranking Conditions

The following conditions must be met to allow engine cranking:

1. Insert the ignition switch key.
2. Turn key to START position and held.

Starting System Logic

If turn key to START position and hold for more than 5 seconds while the throttle pedal is depressed more than 60%, the engine will crank but will not start (engine drowned mode). If the START button is held after engine has started, the ECU automatically stops the starter if engine speed reaches at least 1250 RPM.

TROUBLESHOOTING

DIAGNOSTIC TIPS

NOTE: It is a good practice to check for fault codes using Diagnostic Tool as a first troubleshooting step.

Starting system failures are not necessarily related to the starter but may be due to one the following:

- Crankshaft position sensor (CPS)
- Starter solenoid fuse and start fuse
- Battery, refer to CHARGING SYSTEM
- Starter solenoid and start motor
- Ignition switch
- ECU
- Wiring/connections.

Check these components before removing the starter.

NOTE: This subsection assumes the problem is related to an electrical component of the starting system. If the starting system tests good, ensure engine is in good condition. Refer to applicable subsection.

DIAGNOSTIC GUIDELINES

NOTHING HAPPENS WHEN START/RER BUTTON PRESSED

1. Battery not connected
 - Connect battery.
2. Burnt fuse
 - Check fuses
3. Defective internal ECU relay or related circuits
 - Test power and ground circuits to starter sole node.
4. Defective Ignition Switch
 - Test Ignition switch, wiring and connections.

ENGINE DOES NOT CRANK

1. Discharged battery
 - Recharge and test. Refer to CHARGING SYSTEM subsection.
2. Battery connections
 - Check/clean/tighten.
3. Poor/bad or corroded ground contacts (engine, battery ground cable, starter etc.)
 - Check/clean/repair.
4. Starter solenoid
 - Test solenoid, wiring and connections.
5. Damaged starter or ground cables
 - Carry out SOLENOID DYNAMIC TEST.
6. No ground provided by ECU to starter solenoid
 - Refer to IGNITION SWITCH in this subsection.
7. Engine cannot be rotated (possibly seized)
 - Refer to ENGINE subsection.

ENGINE CRANKS SLOWLY

1. Loose, corroded or dirty battery cable connections
 - Check/clean/tighten.
2. Discharged/weak battery
 - Recharge and test. Refer to CHARGING SYSTEM subsection.
3. Low voltage from starter solenoid
 - Carry out a SOLENOID DYNAMIC TEST.
4. Damaged starter or ground cables
 - Carry out SOLENOID DYNAMIC TEST.

STARTER TURNS, BUT STARTER DRIVE DOES NOT MESH WITH RING GEAR

1. Worn starter drive gear/starter gear/ring gear
 - Replace worn parts. Refer to MAGNETO AND STARTER subsection.
2. Defective drive
 - Replace starter drive. Refer to MAGNETO AND STARTER subsection.

STARTER KEEPS RUNNING

1. Sticking solenoid contacts
 - Replace solenoid.
2. Sticking or defective starter drive
 - Lubricate or replace.

PROCEDURES

FUSES

Make sure the positive fuses are in good condition.

BATTERY

To check battery condition, refer to *Battery* in the *CHARGING SYSTEM*.

IGNITION SWITCH

To check ignition switch, refer to *Ignition Switch* in the *IGNITION SYSTEM*.

STARTER SOLENOID

Starter Relay

The starter solenoid is located beside the fuse box and the battery, under the operator's seat.

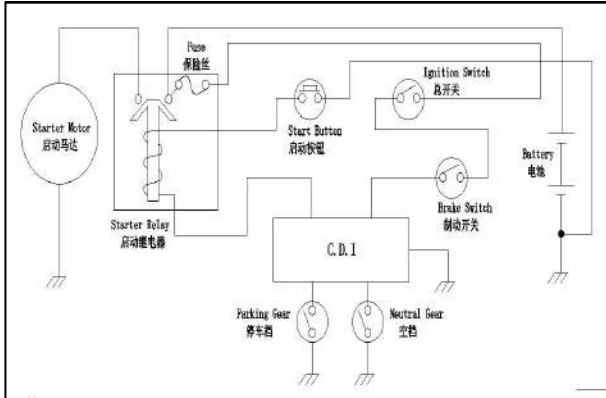

Solenoid Input Voltage Test

Disconnect terminals from solenoid.
Turn ignition switch on and set shift in Park position.
Use a multimeter and set it to Vdc.
Press ignition switch measure the voltage as following.

Ignition Switch	Wires	Voltage
Depressed and held	Green/yellow and Battery ground	Battery voltage

If voltage is good, test solenoid. See below.

Solenoid Coil Resistance Test

Disconnect terminals from solenoid.
Use a multimeter and set it to Ω.
Measure the resistance as following table.

Solenoid Coil Resistance Test		
Solenoid Terminal		Resistance @ 20°C (68°F)
A	B	Approximately 5 Ω

If test fails, replace solenoid.

Solenoid Static Test

Disconnect terminals from solenoid.
Use a multimeter and set it to ohm.
Measure primary winding resistance as following.

Solenoid Terminal		Resistance @ 20°C (68°F)
A	B	Approximately 5 Ω

Check for stuck solenoid plunger.

Solenoid Post		Measurement
Battery Post	Starter Post	Open circuit

If any measurement is out of specification, replace solenoid.

Solenoid Dynamic Test

Turn ignition switch on and set shift in Park position.
Set engine stop switch to OFF to prevent engine starting.

Use a multimeter and set it to Vdc.
Depress start/stop switch and while engine is cranking, measure the voltage drop as follows.

Solenoid Post		Measurement
Post coming from battery	Post going to starter	0.2 Vdc max.

If voltage is out of specification, replace start solenoid.

Removal

1.Disconnect battery. Refer to CHARGING SYSTEM subsection.

⚠WARNING
Always disconnect BLACK (-) cable first and reconnect last.

- 2.Disconnect solenoid cables.
- 3.Disconnect starter solenoid connector.
- 4.Loosen M6 screws, then remove the solenoid.

Installation

Reverse the removal procedure and pay attention to the following.

Tighten M6 screws for solenoid to torque: 9~12Nm.

START MOTOR

Starter Test

Remove operator's seat and Tilt cargo box.
Using booster cables, carefully supply current from the battery directly to the starter. Connect the BLACK (-) cable first. Then connect the remaining jumper cable from the battery to the starter.
If starter does not turn, replace it.

Starter Removal

Turn OFF ignition switch.
Disconnect BLACK (-) cable from battery.

⚠WARNING
Always disconnect BLACK (-) cable first and reconnect last.

- Tilt cargo box.
- Loosen M6 bolts, then remove starter shield.
- Disconnect RED (+) cable from starter.
- Clean starter area.
- Remove M6 bolts for start motor.
- Pull starter out.

Disassembly

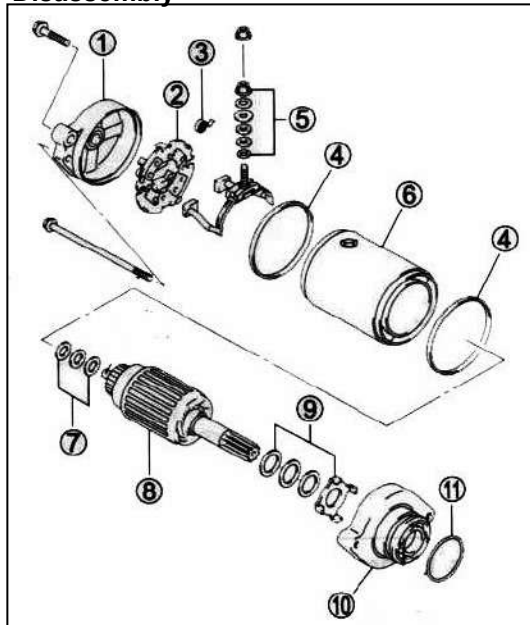

1. Bracket
2. Brush holder
3. Brush spring
4. O-Ring
5. Washer
6. Motor housing
7. Washer
8. Armature coil

- 9. Washer supporting tools
- 10. Inner bracket
- 11. O-Ring

Brush

-Check the brush on the brush holder whether it is worn abnormal, cracked or not smooth.

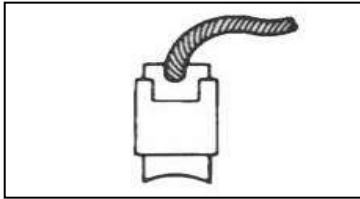

Worn, cracked, or not smooth: → Replace

Rectifier

-Check the rectifier whether it is discolored, abnormal wear or concave.

Abnormal wear or damage: → Replace

-If the rectifier is discolored, grind it with sanding paper, then wipe it with a clean fabric.

-If there is concave, scrape off insulator **B**, so that the distance with **A** is **d**.

$d \geq 1.5\text{mm}$

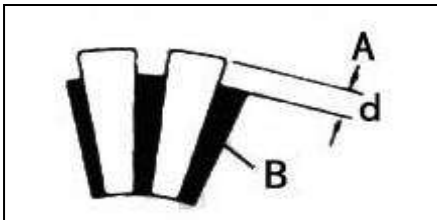

Armature coil

-Test the connection between each wire and the armature coil with the multimeter.

-If they are not connected, replace the armature shaft.

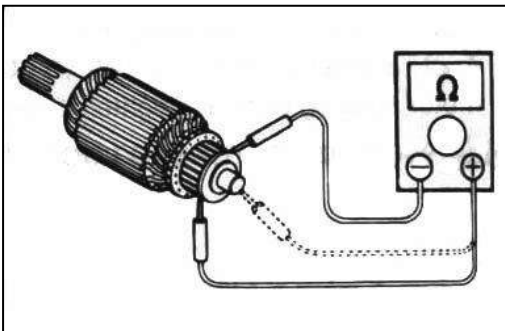

Oil seal

-Check the oil seal lip for damage or leak.

Damage or leakage: → Replace the starter motor.

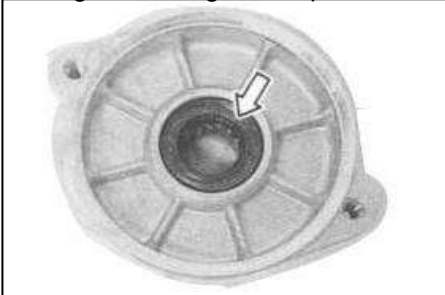

Starter relay

-Inter-terminal voltage is 12V. Test the direct connection of positive and negative poles with the multimeter.

-If the starter relay clicks and connected, the starter relay is OK.

-When there is no voltage of 12V, they are not connected, the starter relay is OK.

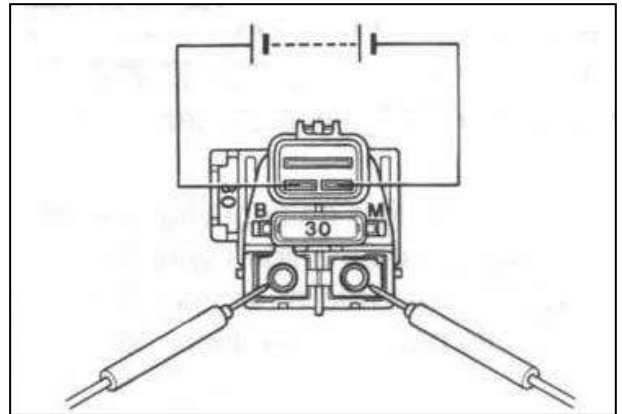

Note: Do not apply battery voltage on the starter relay for more than 2 seconds. This will result in overheating or damaging the relay coil.

-Measure the coil resistance with the multimeter. If the resistance exceeds the specified value, replace the starter relay.

The multimeter is set to $1 \times 10\Omega$.

Starter relay coil resistance: 3-5 Ω .

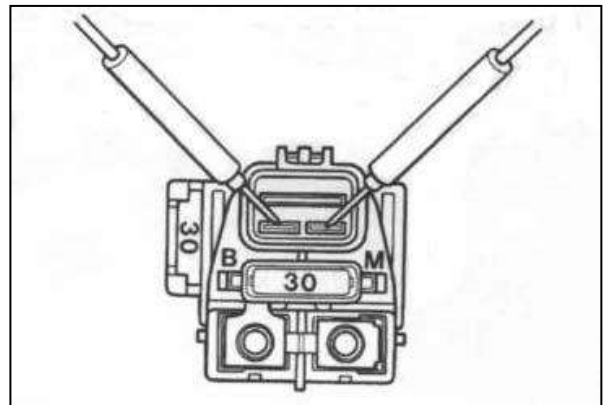

Starter Installation

Installation is the reverse of removal procedure. However, pay particular attention to the following.

Make sure that starter and engine mating surfaces are free of debris. Serious problem may arise if the starter is not properly aligned.

Torque starter screws to 10 Nm (89 lbf.in).

Connect the RED (+) cable to the starter and torque nut to 6 Nm (53 lbf.in). Apply dielectric grease on terminal and nut.

First connect RED (+) cable to battery then connect the BLACK (-) cable.

⚠ WARNING

Always connect RED (+) cable first then BLACK (-) cable last. Whenever connecting the RED (+) cable to the starter motor, make sure the battery cables are disconnected to prevent electric shock.

Test starter operation.

12.3 EFI SYSTEM

Schematic diagram of EFI system

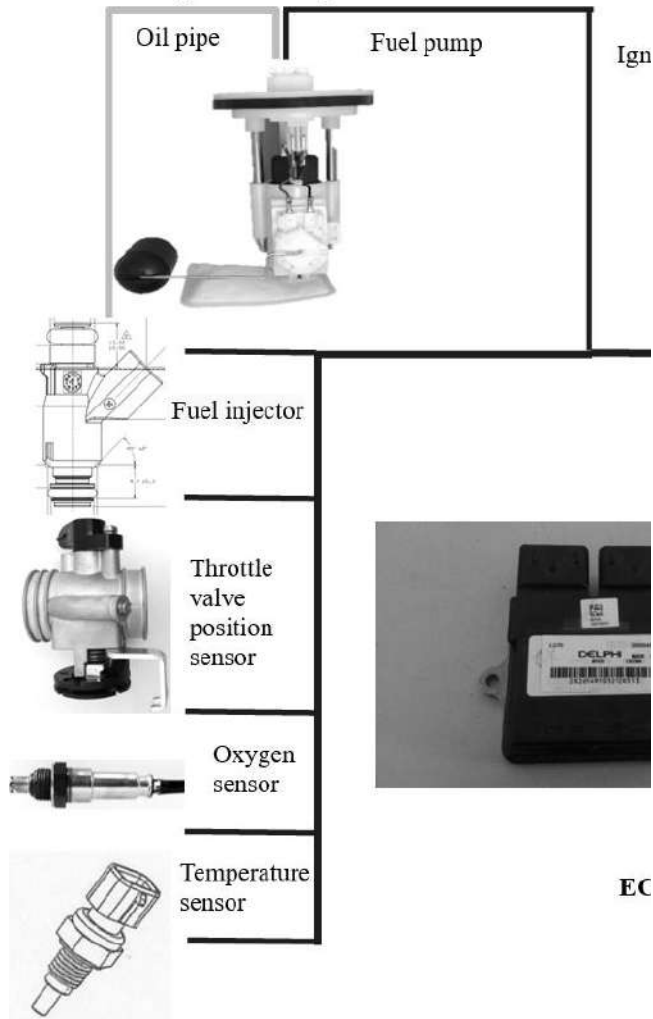

GENERAL

The function of EFI system includes two parts: fuel injection management and ignition management, which are realized by the following institutions.

(1). ECU: it is responsible for the receiving of sensor signal, the formulation of control strategy, and the issue of control signal.

(2). Oil supply device: it is composed of oil pump, tubing and injector. The pump pressurizes the fuel to 350 KPa. The injector is installed on the engine inlet to control the injection timing and fuel injection amount.

(3). Ignition device: it is composed of ignition module, high voltage wire and spark plug. The ignition module has a DC capacitor igniter and a high voltage ignition coil, which can raise the voltage of the battery from 12V to more than 15000V, which also can be transported to the spark plug by high-voltage wire to generate spark discharge.

(4). Sensors: including: a. The oxygen sensor, which mounted on an exhaust pipe to detect oxygen concentration in exhaust gases, can realize the closed-loop regulation of the mixture concentration, and when the closed-loop adjustment, the output of 0-0.9V alternating signal can be achieved;

b. Cylinder temperature sensor, which is installed on the engine cylinder head to detect the engine body temperature, will affect the starting thickening amount;

c. Crankshaft position sensor, which is integrated on magneto to provide crankshaft angle signal, is the time reference for fuel injection and ignition control;

d. The throttle position sensor is mounted on the throttle body to measure the rotation angle of the throttle valve.

(5). Other: including: a. throttle body, which controls air intake through throttle pull wire;

b. Fault alarm lamp, which is installed on the dashboard for fault alarm;

c. Battery, fuse for power supply to EFI system.

INSPECTION

Fuel Gauge /Fuel Level Sensor

Tilt cargo box.
Remove fuel sensor from fuel tank.



Hold fuel sensor in an upright position after removing it. It is normal if indicator shows “E” , otherwise, circuitry connection, fuel sensor or instrument should be inspected.



Turn fuel sensor upside down. It is normal if indicator shows “F”, otherwise, circuitry connection, fuel sensor or instrument should be inspected.



Measure fuel sensor resistance.

FLOAT POSITION	RESISTANCE (20°C/ 68°C)
Top(Full)	≥86Ω
Bottom(Reserve)	≤15Ω

If resistance is not within empty and full values (depending on fuel quantity), check and repair wiring and/or connectors between multifunction gauge and fuel level sender.

If they test good, replace fuel pump. Refer to FUEL SYSTEM.

If fuel level sender and wiring/ connectors are good, try a new multifunction gauge.

12.4 IGNITION SYSTEM

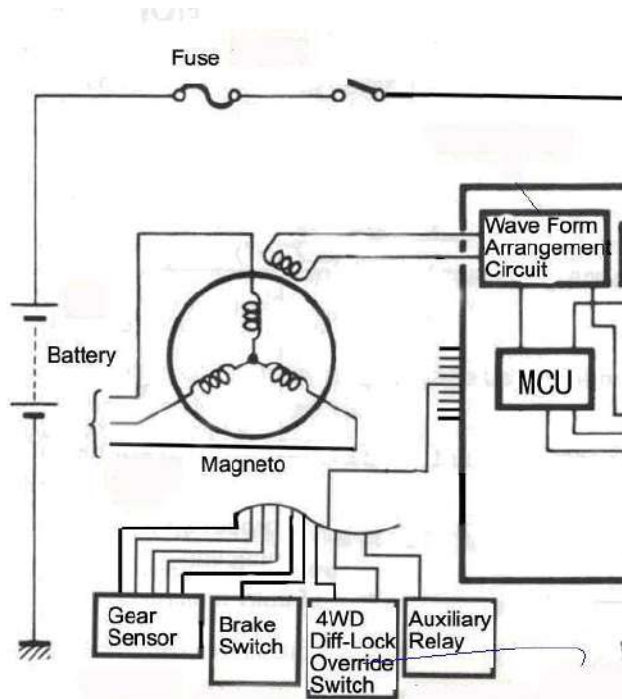

TROUBLESHOOTING

No Spark, Weak or Intermittent Spark

- Spark plug gap incorrect
- Fouled spark plug
- Faulty spark plug cap or poor connection to high tension lead
- Related wiring loose, disconnected, shorted, or corroded
- Engine stop switch or ignition switch faulty
- Terminal board or connections wet, corroded
- Poor ignition coil ground (e.g. coil mount loose or corroded)
- Faulty stator (measure resistance of all ignition related windings)
- Incorrect wiring (inspect color coding in connectors etc.)
- Faulty ignition coil winding (measure resistance of primary and secondary)
- Worn magneto (RH) end crankshaft bearings
- Sheared flywheel key
- Flywheel loose or damaged
- Trigger coil air gap too wide (where applicable) should be 0.030-0.050in (0.75-1.25 mm)
- Excessive crankshaft run out on magneto (RH) end should not exceed 0.005in(0.13mm)
- Faulty ECU

IF THE IGNITION SYSTEM FAILS TO OPERATE

Inspection

1. Fuse

Check ignition switch for continuity or not. If it not continuity, replace the fuse.

2. Battery

Check the battery condition refer to Battery Inspection in this section. If battery is incorrect, as following:

Clean battery terminals.

Recharge or replace the battery.

3. Spark plug

-Check the spark plug condition.

If it is out of specification, repair or replace the spark plug.

-Check the spark plug type.

Standard Spark Plug	DCPR8E / NGK
---------------------	--------------

-Check the spark plug gap.

Spark Plug Gap	0.8 to 1.0mm
----------------	--------------

4. Ignition spark gap

-Disconnect the spark plug cap from the spark plug

-Connect the ignition test as following

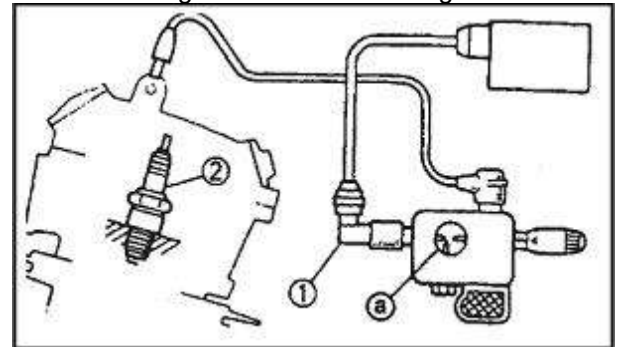

-Turn the ignition switch to ON position

-Check the ignition spark gap

-Check the spark by pushing the starter switch, and increase the spark gap until a misfire occurs.

If meet specification, the ignition system is not faulty.

5. Resistive cable with Spark Plug cap resistance

-Remove the spark plug cap

-Remove the resistive cable from the ignition coil

-Connect the pocket tester($\Omega \times 1K$) to the spark plug cap and the resistive cable terminal.

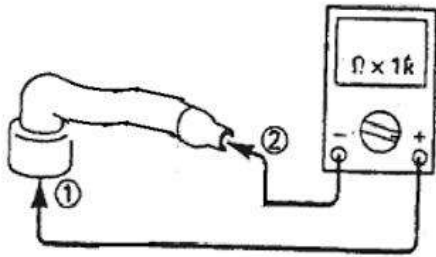

Tester(+) lead → Spark plug side ①
 Tester(-) lead → High tension cord side ②

NOTE:

- When removing the spark plug cap, do not pull the spark plug cap from the resistive cable.
- Remove → Pulling
- Connect → Pushing
- Check the resistive cable with spark plug cap

Resistive cable resistance	$3.68 \pm 0.73K \Omega (@20^{\circ} C)$
----------------------------	---

If out of specification, replace the resistive cable.

6.Ignition coil resistance

Disconnect the ignition coil connector from the wire harness

- Connect the pocket tester to the ignition coil.
- Check if the primary coil has the specified resistance.

Primary coil resistance	$0.58 \pm 0.058 \Omega (@20^{\circ} C)$
-------------------------	---

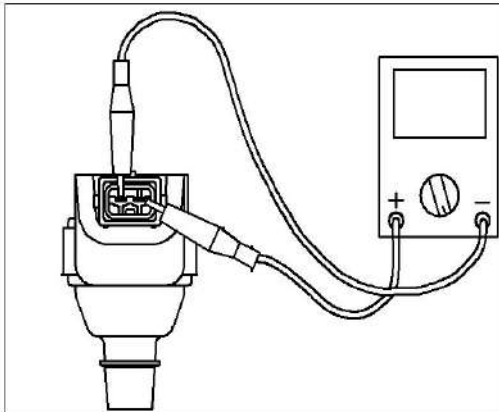

Tester (+) lead → Right Terminal
 Tester (-) lead → Left Terminal

- Remove the resistive cable from the ignition coil
- Connect the pocket tester ($\Omega \times 1k$) to the ignition coil.
- Check the secondary has the specified resistance.

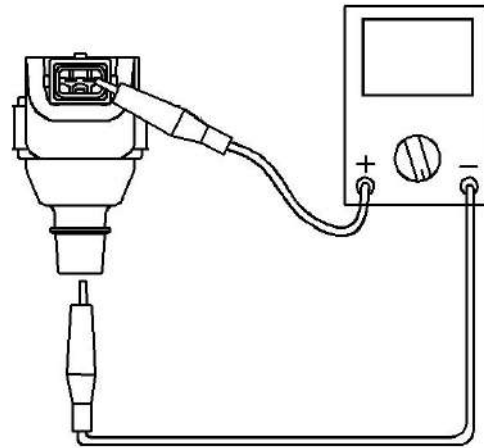

Tester (+) lead → Connector side (Right)
 Tester (-) lead → Resistive cable side

Secondary coil resistance	$9.6 \pm 0.96K \Omega (@20^{\circ} C)$
---------------------------	--

If out of specification, replace the ignition coil.

7.Ignition switch

Check ignition switch for continuity or not. If it not continuity, replace the ignition switch.

8.Wiring connection

- Check the connection of the entire ignition system.
- Refer to the circuit diagram.
- If it corrects, replace the ECU.

PROCEDURES

Safety Precautions

⚠WARNING

To prevent powerful electric shocks while cranking engine, neither touch any electronic ignition components (ignition coil, wire harness, etc.) nor tester lead clips. Also make sure that tester leads do not touch any metallic object.

BATTERY

At least 8V is required for proper ignition system operation. Check battery voltage.

IGNITION SWITCH

Quick Test

- Turn the ignition switch to the ON position.
- If the taillight turns on, the ignition switch is good.
- If the taillight does not turn on (assuming bulb is good), test it.

Switch Power Supply Test

Remove dash and disconnect ignition switch. Measure power supply to switch as follows.

Ignition Switch Connector		Voltage
Red/white	Battery ground	Battery voltage

If voltage is inadequate, test wiring harness.
 If voltage is good, test switch.

Switch Resistance Test

Use a multimeter and measure the resistance between the following wires.

Position	Wire	Resistance
OFF	Black/red	Infinite (OL)
	Blue/red	
ON (w/lights)	Black/red	0.2 ± 0.2 Ω max.
	Blue/red	
START (w/o lights)	Black/red	Infinite (OL)
	Blue/red	

Replace switch if defective.

Switch Removal

Remove the USB holder and unplug the switch connector.

Switch Installation

For the installation, reverse the removal procedure.

TRIGGER COIL

NOTE: The trigger coil is not adjustable.

Static Test: Continuity

Check resistance with a high-sensitivity ohm meter.

1. Remove side panel and disconnect the trigger coil connector.

2. Measure resistance as follows.

Trigger Coil Connector (trigger coil side)	Resistance@ 20°C (68°F)
Green/Yellow Brown/Yellow	774~946 Ω

Dynamic Test: Voltage

1. Disconnect the trigger coil connector.

2. Connect multimeter and measure voltage as follows.

Start Button	Trigger Coil Connector (trigger coil side)	Voltage
Depressed	Green/Yellow Brown/Yellow	0.4~0.7 Vac

3. Repeat operation 3 times.

4. If the trigger coil is out of specification, replace it. If it tests good continue the other tests.

IGNITION COIL

Ignition coil is mounted on frame under the operator's seat.

NOTE: An ignition coil with good resistance measurement can still be faulty. Voltage leak can occur at high voltage level which is not detectable with an ohmmeter. Replacing the ignition coil may be necessary as a test.

Static Test

Primary Winding

Disconnect the wire connector on the primary side of the ignition coil.

Using a multimeter, check the resistance as follows.

Ignition Coil (primary winding)	Resistance @ 20°C (68°F)
Coil terminal Ignition coil body ground	0.9~1.2 Ω

If not within specification, check coil grounding and if good, replace the ignition coil.

Secondary Winding

Disconnect spark plug cap.

Measure resistance as follows.

Ignition Coil (Secondary winding)		Resistance @ 20°C (68°F)
Spark plug cable cap terminal	Ignition coil body ground	9~14 Ω

If resistance is good, continue with the dynamic test.

If test failed, remove spark plug cap to check its resistance.

Spark Plug Cap		Resistance @ 20°C (68°F)
Cable side	Spark plug side	5 kΩ

If cap is not good, replace it.

If cap is good, replace ignition coil.

Dynamic Test

NOTE: The output voltage should not be less than 12 kV (12 000 V).

An ignition coil tester available from aftermarket tool/equipment suppliers can be used.

CAUTION: Do NOT use coil tester on metal work bench. Follow manufacturer instructions.

If the ignition coil is out of specification, replace it. If it tests good ensure the wiring and connectors are in good condition then continue the next tests.

IGNITION TIMING

Ignition timing is not adjustable.

SPARK PLUG

Spark Plug Removal

Unplug the spark plug cable.

Clean the spark plug area with pressurized air.

Unscrew spark plug.

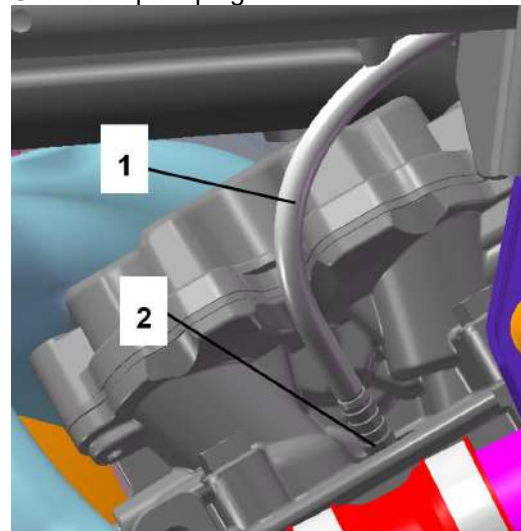

1. Spark plug cable

2. Spark plug

Troubleshooting Fouled Spark Plug

Fouling of the spark plug is indicated by irregular running of the engine, decreased engine speed due to misfiring, reduced performance, and increased fuel consumption. This is due to a loss of compression. Other possible causes are: prolonged idling or low-speed riding, or running on a too rich mixture due to abuse of choke, a clogged air filter, a faulty carburetor adjustment, incorrect fuel, defective ignition system, incorrect ignition timing, incorrect spark plug gap, lubricating oil entering the

combustion chamber, or too cold spark plug. The plug face of a fouled spark plug has either a wet black deposit or a black carbon fouling. Such coatings form a conductive connection between the center electrode and ground.

Spark Plug Analysis

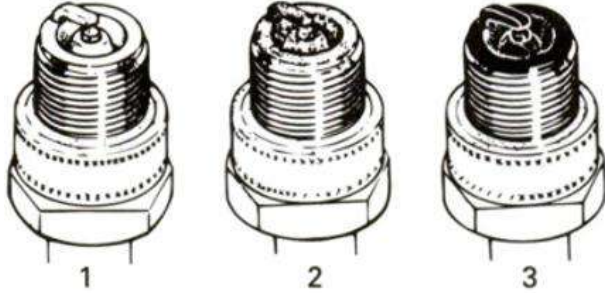

TYPICAL

1. Normal (light brown, brown)

2. Overheated (light grey, white)

3. Fouled (black, wet or dry, dark deposits, grey, melted coating)

The plug face reveals the condition of the engine, operating condition, method of driving and fuel mixture. For this reason it is advisable to inspect the spark plug at regular intervals examining the plug face (i.e. the part of the plug projecting into the combustion chamber).

Spark Plug Installation

Prior to installation make sure that contact surfaces of the cylinder head and spark plug are free of grime.

- Using a wire feeler gauge, set electrode gap to 0.7 mm (0.027 in).
- Apply lubricant over the spark plug threads to prevent possible seizure.
- Hand screw spark plug into cylinder head and tighten with a torque wrench and a proper socket.

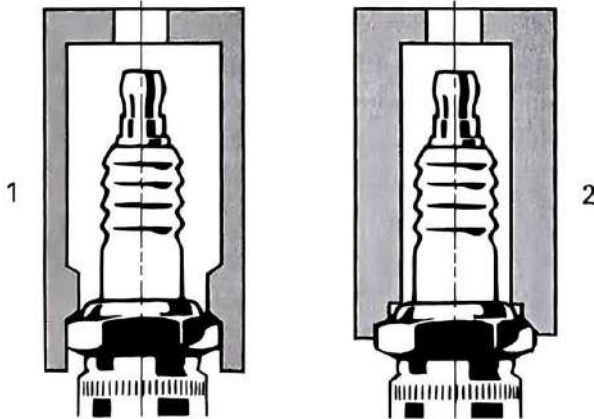

1. Proper socket

2. Improper socket

- Torque spark plug to 20 N m (15 lbf.ft).

12.5 Light System

12.5.1 Headlight

NOTICE: Poor lighting can result in reduced visibility when driving. Headlight and taillight lenses become dirty during normal operation. Clean lights frequently and replace burned out lamps promptly. Do not operate this vehicle at night or in low light conditions until the headlight is replaced. Always make sure lights are adjusted properly for best visibility.

When servicing a halogen lamp, don't touch the lamp with bare fingers. Oil from your skin leaves a residue, causing a hot spot that will shorten the life of the lamp.

Replacement

1. Remove the front headlight cover.
2. Locate the bulb on the back side of the headlight housing.
3. Disconnect the harness from the bulb.

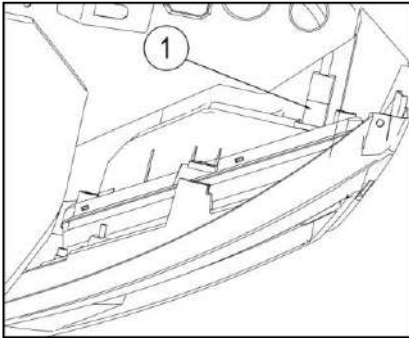

Headlight Beam Aiming

Turn adjustment screw to adjust beam height to your convenience.

NOTE: Adjust headlights evenly.

Headlight Beam Adjustment

To adjust the headlight beam, do the following:

1. Load the vehicle as per normal use.
2. Position vehicle on a level surface, 7.6 m (25 ft) in front of a test surface (wall or screen) as in first illustration.
3. Measure the distance from the center of each headlight to the ground (high beam and low beam).
4. Trace a line on the test surface parallel to the ground at each measured height (one for high beam and one for low beam).

Low beam aiming is correct when the cutoff at the top of the beam is on the applicable horizontal center line on the test surface.

High beam aiming is correct when the center of the high beam (focus point) is 33 mm (1-5/16 in) above the applicable horizontal center line traced on the test surface as per specification.

NOTE: The headlights can only be adjusted vertically.

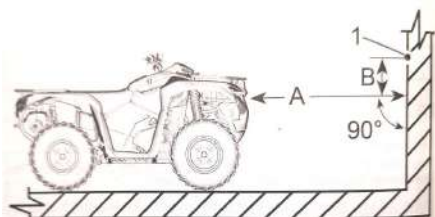

1. High beam focus point

A. Distance between headlight and the test surface

B. Beam aiming specification

5. Turn adjustment screw to adjust the headlight as needed.

Installation

For installation, reverse the removal procedure.

12.5.2 Tail light

Removal

- Disconnect light connector.
- Loose the three M6 bolts and nut, then remove the taillights.

Installation

For installation, reverse the removal procedure.

12.5.3 License plate light

Removal

- Disconnect license plate light connector.
- Loose the two M6 bolts then remove the license plate light from bracket.

Installation

For installation, reverse the removal procedure.

Tightening torque of M6 bolt: 9-12Nm.

12.5.4 Trailer power

Loose the M5 bolts and nut, then remove the trailer power from frame.

Installation

For installation, reverse the removal procedure.

Tightening torque of M5 screw: 5-9Nm.

12.5.5 Top light

Remove M8 bolts and nuts and then remove top light from roof.

Installation

For installation, reverse the removal procedure.

12.6 Cooling System

IF THE FAN MOTOR FAILS TO TURN

Inspection

1.Fan fuse

Check fan fuse. If not continuity, replace the fuse.

2. Battery

Check the battery condition refer to Battery Inspection in this section. If battery is incorrect, as following:

-Clean battery terminals.

-Recharge or replace the battery

3.Fan relay

Check fan relay. If not continuity, replace the relay.

4.Ignition switch

Check ignition switch for continuity or not. If it not continuity, replace the ignition switch.

5.Fan motor

Connect the battery to the fan motor. Check the fan motor operation. If does not move, replace the fan motor.

6. Thermostat switch

Remove the thermostat switch from the radiator.

Connect the pocket tester ($\Omega X1$) to the thermostat switch①.

-Immerse the thermostat switch in the water ②

-Check the thermostat switch for continuity.

NOTE: Measure temperatures while heating the coolant with the temperature gauge

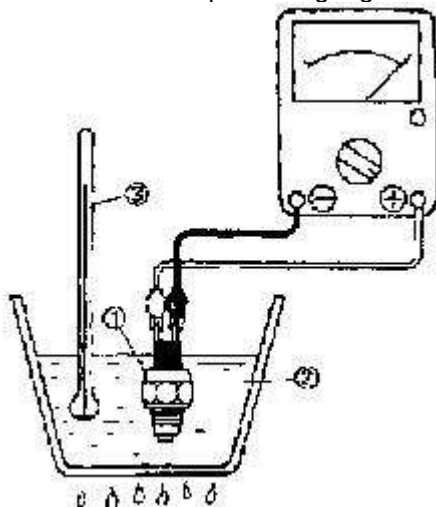

NOTICE:

-Handle the thermostat switch with special care.

Never subject it to strong shocks or allow it to be dropped. Should it be dropped, it must be replaced.

-Do not touch the thermostat switch to the bottom of the heated vessel.

88±3°C--Thermostat switch "ON"

80°C--Thermostat switch "OFF"

If out of specification, replace the thermostat switch.

7.Wiring connection

-Check the connection of the entire cooling system. Refer to the circuit diagram. If incorrect, replace the wiring connection.

12.7 Fuses

Removal

Tilt cargo box.

Loosen two M6 bolts and remove main fuse box.

Remove operator's seat, battery cover.

Disconnect BLACK (-) cable from battery.

⚠WARNING

Always disconnect BLACK (-) cable first and reconnect last.

Remove fuse holder hosing and positive fuse holder.

Tightening torque of M6 bolt for fuse box: 9-12Nm.

Fuse Inspection

Check fuse condition and replace it if necessary.

To remove fuse from holder, pull fuse out. Check if filament is melted.

Fuse description

F1	Ignition Switch	20A
F2	USB	20A
F3	EPS	40A
F4	Fan	40A
F5	Light Power	20A
F6	Wiper Motor	20A
F7	2WD/4WD Switch	10A
F8	Horn	10A
F9	Top Light	15A
F10	EFI	15A
F11	EPB	30A
F12	Oil Cooler Fan	10A
F13	AC	50A
F14	Vehicle Power	100A
F15	Charging Power	150A
F16	Winch positive	175A

12.8 Relay

Ensure to align tabs of relay with terminals of fuse holder at installation.

The easiest way to check a relay is remove it and bypass it with a jumper. If the components then work, replace the relay. See illustration to find where to bypass the relays.

Relays	RY 1	EFI Relay
	RY 2	Light Relay
	RY 3	Top Light Relay
	RY 4	Wiper Power Relay
	RY 5	Fuel Pump Relay
	RY 6	2WD/4WD Switch Relay 1
	RY 7	2WD/4WD Switch Relay 2
	RY 8	Oil Cooler Fan Relay
	RY 9	Low Headlight Relay
	RY 10	High Headlight Relay
	RY 11	Fan Relay
	RY 12	Horn Relay
	RY 13	AC Relay
	RY 14	Left Steering Relay
	RY 15	Rear Steering Relay

12.9 Speed meter System

Operation Of Speed Sensor

Speed sensor on the gearbox output shaft.

The following is the graphic illustration for sensor installation

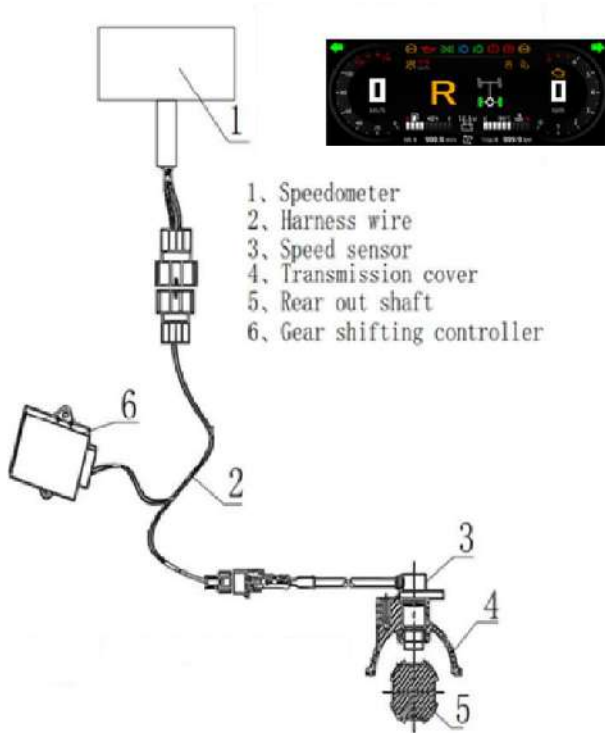

Turn ignition key ON.

Set engine run/ stop switch to RUN.

Use a multimeter and set it to Vdc.

Back-probe connector and read voltage as follows.

Speed Sensor Connector (harness side)		Voltage
Grey/red	Red/blue	Battery voltage

If voltage is not good, check/ repair wiring/connectors.

If voltage is good, do the following test.

Lift rear of vehicle so that rear wheels are off the ground.

Set transmission to 2WD and to Neutral.

Back-probe connector and read voltage while slowly rotating rear wheels with your hands.

If voltage is appropriate, check/repair wiring/ connector between sensor and BCM. If it is good, try a new BCM.

If voltage is wrong, try a new sensor.

12.10 Gear Position Indicator Sensor

Using a multimeter, measure the voltage as follows.

Gear position indicator sensor	BCM Pin	Voltage
Pin3 (Orange/black)	Pin1(Black)	5 Vac

If there is no voltage, check fuses, relay and wiring condition.

12.11 Oil Pressure Sensor

Switch Activation

When oil pressure is high than 13kPa, the switch is cut off.

When oil pressure is lower than 13kPa, the switch is connected.

Removal

Unplug and unscrew the oil pressure sensor. This sensor is located in the area between cylinder head and gearbox shift shaft.

Installation

Apply Loctite 234(blue) and torque switch to 9~12Nm.

12.12 2WD/4WD Switch/Front Diff Lock Switch

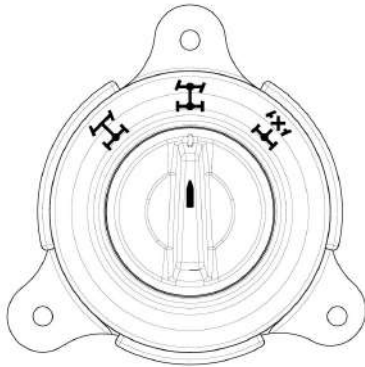

1. The rider turn the switch on dash.
2. The Switch gives signal to BCM.
3. The BCM gives power to the solenoid.

The switch position sensor fuction:

	Blue/Black	Blue/Green	Brown/Red	Grey	Grey	Grey/White	Light green/Brown	Black
2WD	●	●				●		
4WD	●		●	●				
Lock			●	●			●	●

Troubleshooting

Inspection

1. Fuse
Check 2WD/4WD switch for continuity or not. If it not continuity, replace the fuse.
2. Battery
Check the battery condition refer to Battery Inspection in this section. If battery is incorrect, as following:
Clean battery terminals.
Recharge or replace the battery.
3. Ignition switch
Check ignition switch for continuity or not. If it not continuity, replace the ignition switch.
4. 4WD/Diff lock switch
Check the operation of 4WD/Diff lock switch. If not continuity, replace the switch.
5. 2WD/4WD Relay 1 and Relay 2
Disconnect solenoid switch from the wire harness

Connect the solenoid to the battery.

Battery(+) lead → **Orange terminal**

Battery(-) lead → **Black ground**

If the switch does not move, replace the solenoid switch.

6. Wiring connection

- Check the connection of the entire ignition system. Refer to the circuit diagram.
- If it corrects, replace the ECU.

12.13 Rear differential lock switch

Use a multimeter and set it to Vdc.

Measure the voltage as following.

Switch position	Wires	Ground	Voltage
Unlock	Yellow/Red	Black	Battery voltage
Lock	Brow		

12.14 Multifunction Gauge

GENERAL

Most of the electrical tests require the following tool.

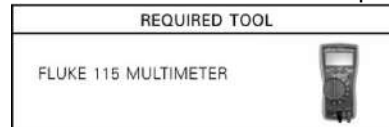

Refer to Wires Diagram subsection for diagnostic tips on troubleshooting electrical problems.

NOTICE: It is recommended to always disconnect the battery when replacing any electrical component. Always disconnect battery as specified, BLACK (-) cable first.

INDICATOR LAMPS DESCRIPTION







Important information about vehicle condition is displayed on the multifunction gauge. When starting the engine, always look at the gauge for any indicator lamps or special messages.

Important information messages can also be displayed by assist indicator lamps.



NOTE: Depending on the vehicle, not all the indicator lamps and messages will be applicable.

Item	Function	Icon
1	Left turn	
2	Right turn	
3	Position light	
4	High beam	
5	Low beam	
6	Engine fault	
7	EPS	

8	ABS fault	
9	Brake fault	
10	Oil change	
11	Trailer indicator light	
12	Handbrake activation	
13	Speed limit	

TROUBLESHOOTING DIAGNOSTIC TIPS

IMPORTANT: When solving an electrical problem, the first thing to do is to check the battery condition as well as its cables and connections. Make sure the battery is fully charged or install a power pack for any tests that involves a prolonged "key ON" period. If battery voltage gets too low, not only test results can be altered, but the vehicle electrical system may not operate normally. Pay attention to ground wires. They could become loose or corroded which causes them to act as an additional load in a circuit, dropping voltage and reducing current to components. Some components may be grounded through their outer casing and mounted hardware. This should also be considered.

Electrical Connectors

Pay particular attention to ensure that pins are not out of their connectors, loose, or damaged. The troubleshooting procedures may not cover problems resulting from one of these causes.

NOTICE: Ensure all terminals are properly crimped on wires and connect or housings are properly fastened. When replacing any electric or electronic part(s), always check electrical connections. Make sure that they are clean, corrosion-free, tight and make good contact. The voltage and current might be too weak to go through dirty or corroded connector pins or terminals.

MULTIFUNCTION GAUGE TROUBLESHOOTING GAUGE FUNCTIONS INOPERATIVE OR WORKING INTERMITTENTLY

1. Power supply or ground problem
-Check power supply and ground circuits.

PROCEDURES

Testing the Multifunction Gauge

Before beginning any troubleshooting, test or repair, always check for fault codes.

1. Check for fault codes using DELPHI DIAGNOSTIC TOOL.
2. Record all fault codes, then erase them.
3. Perform a complete shutdown of the electrical system and reactivate it.
4. Check fault codes. If a previous fault code reappears, perform the required service actions.

Testing the Multifunction Gauge Using DELPHI DIAGNOSTIC TOOL

Connect the DELPHI DIAGNOSTIC TOOL to OBD. In DELPHI DIAGNOSTIC TOOL, go to:
-Functions page
-Cluster button
-Routines-Execute Cluster WOW test.
All indications will come and stay ON so that you can verify each indication.

NOTE: The WOW Test only tests the gauge LEDs and LCD. It does not test the actual circuit functions related to each indication.

Testing the Multifunction Gauge Power Input

If the multifunction gauge is inoperative, first check for fault codes with DELPHI DIAGNOSTIC TOOL, record all faults then erase them. Reactivate the electrical system and recheck for faults. If any fault code appears, perform service actions required.

1. Remove multifunction gauge.
2. Perform the test at multifunction gauge connector as per following illustration and tables.

If there is no power at pin 9(Black), check fuse and the related circuit.

If the power test is within specification, continue with TESTING THE MULTIFUNCTION GAUGE GROUND CIRCUIT.

Testing the Multifunction Gauge Ground Circuit

Test as per the following table.

If the ground at pin 9(Black) is not within specification, check the related circuit.

If the ground tested to specification, continue with TESTING THE MULTIFUNCTION GAUGE CAN WIRE CIRCUIT.

Testing the Multifunction Gauge CAN Circuit

- 1.Remove the front service cover for access to the OBD. Refer to BODY subsection.
2. Test as per the following table.

Multifunction Gauge CAN WIRE TEST		
CL Connector	OBD	Results
Pin7 Pink (CAN L)	Pin 4 (Black)	Close to 0.4 Ω
Pin8 Purple (CAN H)		Close to 0.4 Ω

If the CAN wire verification test fails, check the related circuit.

If the multifunction gauge functions, however there is a suspected communication problem with another component, perform this test between the multifunction gauge and that component.

If the multifunction gauge power, ground and CAN verification tests are all to specifications and the multifunction gauge is inoperative, replace the multifunction gauge.

Removing the Multifunction Gauge

Remove gauge cover. Refer to procedure in BODY subsection

Disconnect the gauge connector. Remove following fasteners.

1. Loosen two M6 screws, disconnect the wires from gauge.
2. Remove gauge cover from gauge cover bracket.
3. Loosen M6 screws, separate gauge cover and gauge.

Installing the Multifunction Gauge

The installation is the reverse of the removal procedure. However, pay attention to the following.

TIGHTENING TORQUE	
Gauge screws	9~12 Nm

If the multifunction gauge was replaced, connect the vehicle to the DELPHI DIAGNOSTIC TOOL and apply any available updates. Also set the odometer reading, engine hours, time language the menu on the gauge.

Menu settings

Buzzer alarm: Sound alarm is triggered based on the vehicle status.

Text-based alarm: Text-based alarms include:

Item	Text-based alarm
1	Reset maintenance mileage
2	The parking brake is released.

Reset Maintenance Mileage:

When the remaining maintenance mileage is 0 km, a pop-up window prompts for a reset operation. Clicking the "Yes" button resets the maintenance mileage; clicking the "No" button does not reset the maintenance mileage (the pop-up window is canceled), and a pop-up window will prompt again after restarting the device.

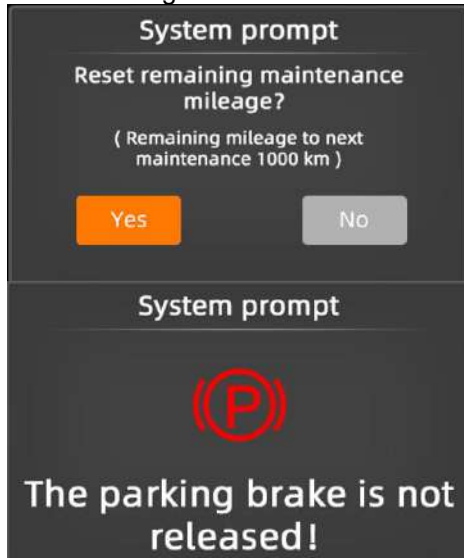

SETTING

Menu entry and exit: Click the area within the square on the screen to display the menu settings items.



In the menu area, simply swipe up and down to scroll through the menu options.

Click on any area other than the menu to exit the menu.



Backlight: Backlight adjustment mode, backlight

brightness value setting.

The backlight adjustment modes are: manual/automatic.

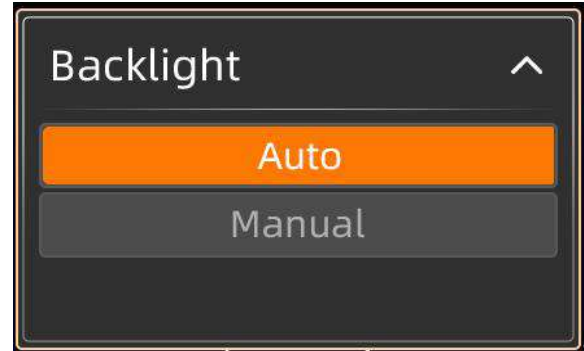

In automatic mode, the backlight brightness of the screen is automatically switched.

In manual mode, the manual adjustment range of brightness is: 1~100. 1 is the darkest and 100 is the brightest.

In manual mode, the backlight brightness values when the near light is turned on and off can be set and memorized separately.

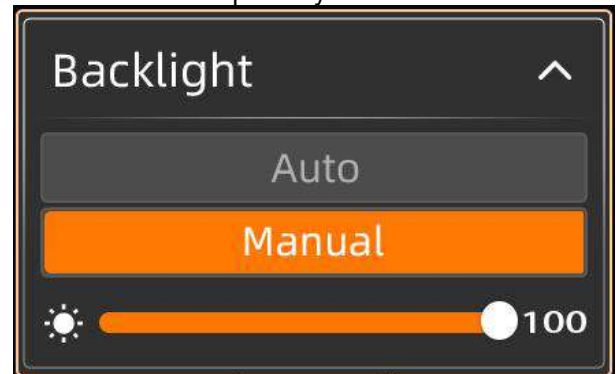

Tire diameter: You can set the option for tire diameter. After setting, it will be remembered.

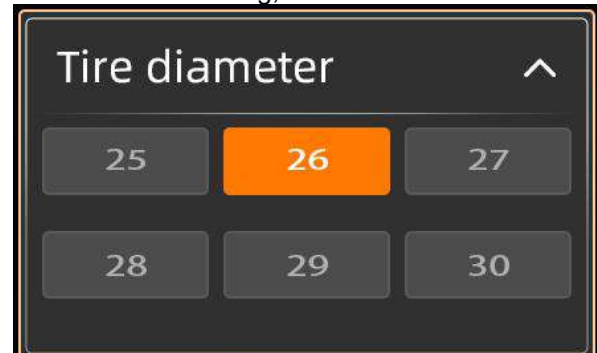

EPS gear position: EPS gear position options can be set. After setting, it will be memorized.

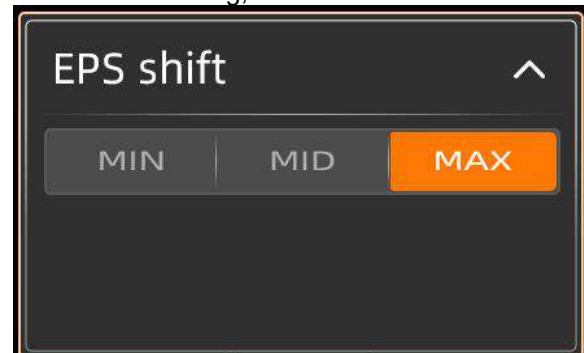

Clock: Set and remember the clock mode (24-hour format, 12-hour format); adjust the time.

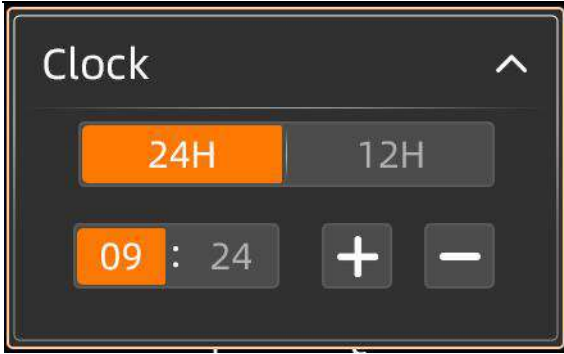

Language: Settings and memory for Chinese, English, or other languages.

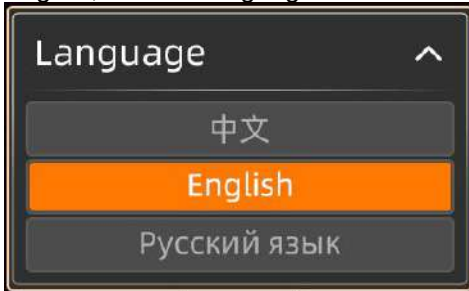

Unit: Set and memorize metric and imperial units.

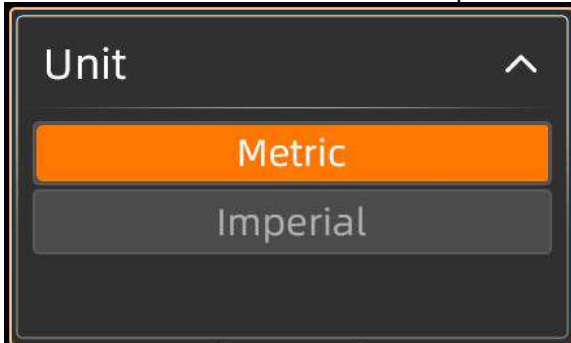

Fault Code: When the vehicle has a specific fault, the fault code will be displayed.



Maintenance Information: Displays the remaining mileage until the next scheduled maintenance. The reminder for the first maintenance is at 500 km, and the subsequent intervals are 2000 km.

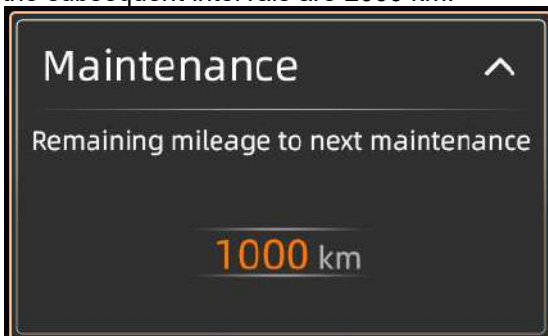

Vehicle Information: Displays the total working

time since the vehicle was started.

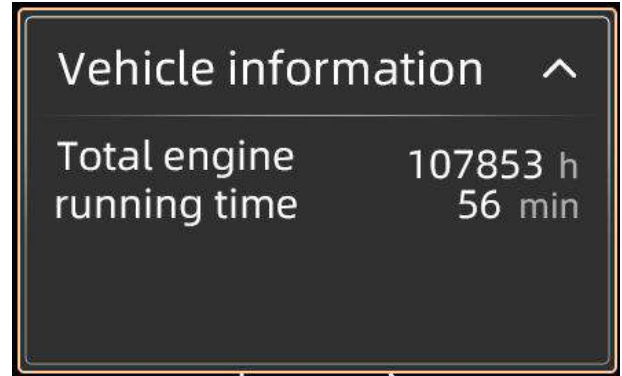

Version: Displays the current software (MCU, APP) version and hardware (HW) version number of the instrument.

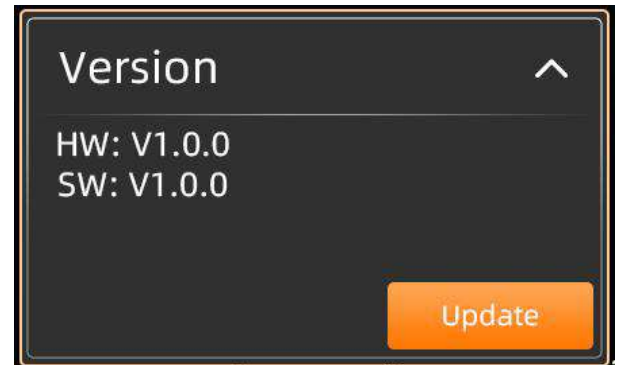

12.15 12-Volt Auxiliary Power Outlet

The 12-volt auxiliary power outlet allows the installation of additional accessories.

Test

The wires are located on the dashboard.

NOTE: Turn ignition key ON.

Using a multimeter, measure the voltage between White/Green and Black wires.

The obtained value should be between 12 and 14.5 Vdc.

- No voltage:
 - Check wiring condition.
- Voltage is good:
 - Check accessories.

12.16 12-Volt Power Outlet

Removal

Remove switch service cover.

Unplug the connectors of the power outlet.

Installation

Reverse the removal procedure.

Test

NOTE: No key required.

Remove the switch service cover.

Unplug the power outlet connectors.

Using a multimeter, measure the voltage between White/Blue and Black wires.

The obtained value should be between 12 and 14.5 Vdc.

- No voltage:
 - Check accessories fuse (15 A) and wiring condition.
- Voltage is good:
 - Change power outlet.

12.17 Multifunction Switch

Place shift lever to NETURAL position and start engine.

Low/Hi Beam Switch

Select low beam position on switch.

Using a multimeter, measure the voltage between GREEN and BLACK wires.

The value should be between 12 and 14.5 Vdc.

Select low beam position on switch.

Using a multimeter, measure the voltage between BULE and BLACK wires.

The value should be between 12 and 14.5 Vdc.

-No voltage

- Check switch and wiring condition.

-Voltage is good:

- Change headlight bulb.

Using a multimeter, measure the resistance between the following wires.

Switch Position	Wire Color		Resistance
Hi Beam	White/Blue	Yellow/Red	$0.2 \pm 0.2 \Omega$ max.
Lo Beam	Bule/Brown		$0.2 \pm 0.2 \Omega$ max.

Replace Low/Hi beam switch if defective.

Light Switch

Using a multimeter, measure the resistance between the following wires.

Ignition Switch	Wire Color	Resistance
Position light position	Brown/White and brown	$0.2 \pm 0.2 \Omega$ max.
OFF position		Infinite(0L)
Light position	Brown/White and brown	$0.2 \pm 0.2 \Omega$ max.
	Yellow/red and Brown/White	

Replace power switch if defective.

Horn Switch

Using a multimeter, measure the resistance between the following wires.

Switch	Wire Color	Resistance
ON position	Brown/white and Red/orange	$0.2 \pm 0.2 \Omega$ max.
OFF position		Infinite(0L)

Replace horn switch if defective.

Top Light Switch

Using a multimeter, measure the resistance between the following wires.

Switch	Wire Color	Resistance
OFF position	Brown/white and Red/green	Infinite(0L)
ON position		$0.2 \pm 0.2 \Omega$ max.

Replace top light switch if defective.

Steering light switch

Using a multimeter, measure the resistance between the following wires.

Switch	Wire Color	Resistance
Left position	Light blue and Black/brown	$0.2 \pm 0.2 \Omega$ max.

Right position	Orange And Black/brown	$0.2 \pm 0.2 \Omega$ max.
----------------	------------------------	---------------------------

Replace steering light switch if defective.

Warning lights switch

Using a multimeter, measure the resistance between the following wires.

Switch	Wire Color	Resistance
ON position	Black/brown And Orange	$0.2 \pm 0.2 \Omega$ max.
OFF position		Infinite(0L)

Replace warning light switch if defective.

Wiper Switch

Using a multimeter, measure the resistance between the following wires.

Switch	Wire Color		Resistance
Wiper position	Blue/yellow	green	$0.2 \pm 0.2 \Omega$ max.
Spray water position	Blue/yellow	green	$0.2 \pm 0.2 \Omega$ max.
	Blue		
OFF position	yellow	green	Infinite(0L)

Replace warning wiper switch if defective.

12.18 Winch

Test

Winch Motor

Using boosting cables, connector pore to IN post of winch the to OUT post.

If motor does not turn in any test, replace motor. If it works, continue testing.

Voltage Supply to Switch

Remove front panel and dashboard. Refer to BODY. Disconnect the winch control switch connector.

Using a multimeter, measure the resistance as follows.

Winch Switch Connector (harness side)		Voltage
Pin A	Battery ground	12 Vac

If there is no voltage, check fuses, relay and wiring condition.

If there is voltage, test switch as follows.

Winch Control Switch

Removal

Remove screws retaining winch control switch to handlebar.

Remove steering cover, refer to BODY.

Disconnect the winch control switch connector.

Remove steering cover, refer to BODY.

Disconnect the winch control switch connector.

Using a multimeter, measure the resistance.

Position	Connector Pin	Resistance
Switch to IN	Brown and Blue/yellow	$< 5 \Omega$
Switch to OUT	Green and Blue/yellow	$< 5 \Omega$

If the resistance is above 5Ω , replace the winch control switch.

Installation

For the installation, reverse the removal procedure.

Winch Relay

Reconnect terminals at winch relay.
Measure voltage drop between relay and motor as follows.

Position	Relay terminal	Voltage Drop
Switch pressed to IN and held	Battery post and IN cable	0.2 Vdc max.
Switch pressed to OUT and held	Battery post and OUT cable	0.2 Vdc max.

If voltage drop read is higher than specification in either test, check wiring/connectors. If they are good, replace winch relay.

If voltage read is battery voltage, the relay does not close. Replace with a new one.

Removal

Disconnect, the battery BLACK (-) cable first, then the RED (+) cable.

⚠ WARNING

Always respect this order for disassembly; disconnect BLACK (-) cable first. Electrolyte or fuel vapors can be present in engine compartment and a spark may ignite them and possibly cause personal injuries.

Disconnect the winch power cables.

NOTE: Note the position of the power cables for reinstallation.

Remove:

- locking pin
 - hook
 - M8 bolts for retaining the winch
- Remove winch.

Installation

For the installation, reverse the removal procedure.

12.19 Electronic parking brake switch

Using a multimeter, measure the resistance between the following wires.

Switch	Wire Color	Resistance
Release position	Light green/red And Light green/white	Infinite(0L)
Park position		0.2 ± 0.2 Ω max.

Replace electronic parking brake switch if defective.

12.20 EPS Controller

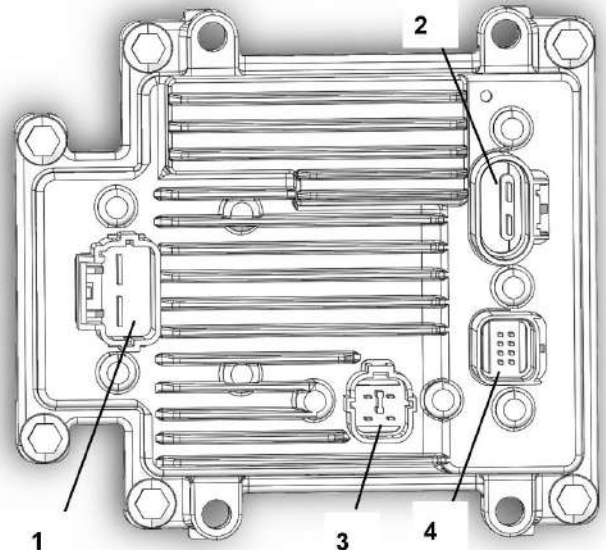

1. Motor drive module(Motor side)
2. Motor drive module(Battery side)
3. Analog/digital conversion
4. Control module

The wires diagram is as following:

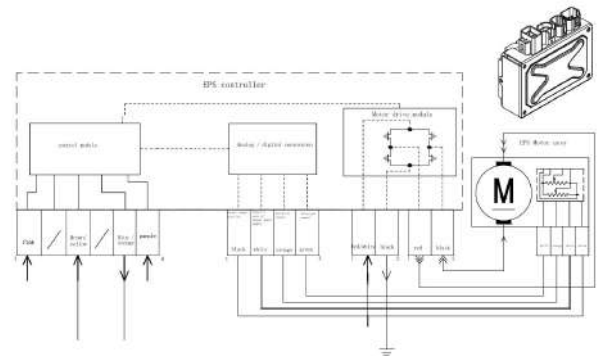

TEST

EPS Power Test

Using a multimeter, measure the voltage as follows.

EPS Connector		Voltage
Control Module	Motor Drive Module	
Pin 1(Red)	Pin1(Black)	12 Vac

If there is no voltage, check fuses, relay and wiring condition.

EPS CAN Resistance Test

Using a multimeter, measure the resistance as follows.

EPS Connector		Resistance
Control Module		
Pin1(Pink)	Pin 6(Purple)	55 Ω

13. TROUBLESHOOTING

ELECTRICAL SYSTEM.....	13-1	COOLING SYSTEM.....	13-1
MAGNETO SYSTEM.....	13-1	LUBRICATION.....	13-2
CYLINDER AND HEAD.....	13-3	CRANKSHAFT.....	13-3
GEARBOX.....	13-3	COUPLING UNIT.....	13-4
CVT.....	13-4	ENGINE GENERAL.....	13-5

13.1 ELECTRICAL SYSTEM

Symptom: NO SPARK OR POOR SPARK

1. Refer to ignition system.

Symptom: STARTER DOES NOT TURN

1. Refer to starting system.

Symptom: STARTER TURNS BUT DOES NOT CRANK THE ENGINE

1. Refer to starting system.
2. Check gear condition on electric starter.
Worn and/or damaged starter gear. Replace electric starter and/or starter drive.
3. Check condition of starter pinion gear.
Worn and/or damaged starter pinion and/or ring gear. Replace starter drive and/or drive pulley fixed sheave.
4. Check splines on starter drive.
Poor movement of pinion gear on splines. Clean and/or replace starter drive.

Symptom: STARTER TURNS BUT STARTER DRIVE DOES NOT MESH WITH RING GEAR

1. Refer to starting system.

Symptom: STARTER KEEPS RUNNING

1. Refer to starting system.

13.2 COOLING SYSTEM

Symptom: HIGH ENGINE OPERATING TEMPERATURE

1. Check coolant level.
Coolant level lower than recommended. Refill (refer to cooling system).
2. Check for air bubbles in cooling system.
Air in cooling system. Refill and bleed cooling system (refer to cooling system).
3. Check temperature sensor for electrical/mechanical failure.
Temperature sensor defective. Replace.
4. Check thermostat.
Thermostat defective (does not open when engine gets hot). Replace (refer to cooling system).
5. Check leak indicator hole (in crankcase MAG side-water pump housing area) if coolant leaks.
Coolant leaking from indicator hole means a damaged water pump rotary seal. Replace rotary seal (refer to cooling system).
6. Check condition of hoses and hose clamps fixation.
-Hoses are brittle and/or hard. Replace.
-Hose clamps are loose. Retighten clamps.
7. Check condition of impeller located on the water pump shaft.
Impeller wirings broken and/or impeller threads are damaged. Replace (refer to cooling system).
8. Check gasket on water pump housing.
Gasket on water pump housing leaks. Retighten screws and/or replace gasket.
9. Check cylinder head and/or cylinder base gasket.
Worn out gasket(s) is (are) causing coolant leakage. Replace.
10. Check coolant drain screw on water pump housing MAG side.
Copper ring on drain screw leaks. Retighten screw and/or replace copper ring.
11. Check intermediate gear(s) behind of PTO cover.
Worn out and/or broken gear(s) is/are causing less coolant supply. Replace worn out and/or broken gear(s) (refer to bottom end).
12. Check if water pump shaft is seized.
Water pump shaft does not turn. Replace defective part(s).
13. Check cooling fan and connection.
-Fan motor faulty. Replace.
-Wire harness is brittle or hard (no connection). Replace.
14. Check radiator fan switch and fuse.
Faulty fan switch and/or faulty fuse. Replace defective part(s).
15. Check radiator condition for leakage.
Radiator cracked or deformed. Replace radiator.
16. Check mud/dust in radiator fins.
Radiator fin obstructed, hard air cooling. Clean radiator fins.

13.3 MAGNETO SYSTEM

Symptom: BATTERY NOT CHARGING OR CHARGING VOLTAGE INADQUATE

1. Check battery
Battery shows less power. Reload battery.
2. Check magneto for damage and/or electrical failure.

- Radial position of rotor wrong due to broken woodruff key. Replace woodruff key.
 - Coating on stator winding is damaged. Replace stator.
 - Resistance value is out of specification (refer to technical specifications). Replace magneto.
 - Connector on magneto is damaged and/or has electrical failure. Repair and clean contacts of connector.
3. Check voltage regulator/rectifier.
Refer to charging system.
 4. Check wiring harness for cracks or other damages.
Harness shows electrical failure and/or other damages. Replace/repair wiring harness.

13.4 LUBRICATION

Symptom: LOW OR NO OIL PRESSURE/HIGH OIL CONSUMPTION

1. Check oil level and search for leakage on crankcase and/or sealing parts.
 - Crankcase is leaking due to damage. Rebuild engine with new crankcase and gasket parts. Use recommended oil (refer to technical specifications).
 - Crankcase is leaking due to loosen screws. Retighten screws with recommended torque
 - Sealing rings, O-rings and/or gaskets are brittle, hard or damaged. Replace damaged parts.
 - Piston rings worn out (blue colored engine exhaust emission). Replace piston rings (refer to cylinder and head).
 - Piston rings are broken (low compression). Replace piston rings (refer to cylinder and head).
 - Valve stem seal damaged and/or sealing lip is hard and/or brittle. Replace all valve stem seals.
2. Check oil filter for contamination.
Oil filter clogged. Replace oil and oil filter at the same time. Use recommended oil (refer to technical specifications).
3. Check oil drain plug on engine bottom.
Plug is loose and/or gasket ring is missing. Retighten the plug and/or place gasket ring.
4. Check leak indicator hole if oil leaks (in crankcase MAG side-water pump housing area).
-Oil leaking from leak indicator hole means a damaged oil seal on water pump shaft.
-Replace oil seal (refer to cooling system).
5. Check oil orifice(s) on the oil pump suction side.
Oil orifice(s) is (are) clogged. Clean from contamination. Replace oil and oil filter if necessary (refer to maintenance or lubrication system).
6. Check oil pump function.
 - Oil pump rotor is out of wear limit. Replace oil pump (refer to lubrication system).
 - Oil pump seized due to oil leakage and/or air inclusion. Replace oil pump (refer to lubrication system).
 - Gears driving oil pump are broken or otherwise damaged. Replace gears.
 - Incorrect oil being used. Use recommended oil (refer to technical specifications).
7. Check oil pressure regulator valve (spring) function.
 - Valve spring damaged (valve always open). Replace spring.
 - Valve piston is worn or broken. Replace valve piston (refer to lubrication system).
 - Valve piston stays open due to contamination. Clean or repair valve piston.
8. Check plain bearings in crankcase for heavy wear.
Plain bearings out of specification (increased clearance). Replace plain bearings (refer to bottom end).
9. Check engine oil strainer in crankcase.
Oil strainer is clogged due to contamination. Clean or replace strainer and diagnose causes. Replace possible damaged parts (refer to bottom end).

Symptom: OIL CONTAMINATION (white appearance)

1. Check leak indicator hole (in crankcase MAG side-water pump housing area) if water and oil leaks.
Leakage of oil/water mixture from indicator bore means damaged water pump seal ring and rotary seal. Replace sealing ring, rotary seal and change oil, oil filter and/or coolant (refer to lubrication system, cooling system and bottom end).
2. Check cylinder head and/or cylinder base gasket.
Gasket damaged or leaking. Retighten cylinder head with recommended torque and/or replace gasket.
3. Check tightening torque of cylinder head screws.
Screws not properly tightened. Retighten screws to recommended torque and replace oil.
4. Check oil for particles (may indicate possible engine internal damages).
Oil contamination due to metal or plastic particles. Replace possibly damaged part(s) including oil and oil filter. Use recommended oil (refer to technical specifications).

13.5 CYLINDER AND HEAD

Symptom: UNUSUAL ENGINE NOISE AND/OR VIBRATION

1. Check noise coming from cylinder head area.
-Improper valve clearance adjustment. Readjust valve clearance and/or replace defective part(s).

- Faulty chain tensioner. Replace spring and/or mechanism.
- Chain guide worn out. Replace chain guide.
- Stretched chain and/or worn-out sprockets. Replace chain and sprockets.
- Sprocket screws got loose. Retighten screws with recommended torque.
- Rocker arm(s) is (are) worn out (valve adjustment). Readjust valve clearance and/or replace rocker arm(s).
- Incorrect camshaft timing adjustment. Replace damaged components and readjust camshaft timing (refer to cylinder and head).

Symptom: OIL CONTAMINATION ON CYLINDER AND/OR HEAD

1. Check screws for torque.
 - Loose screws. Retighten screws with recommended torque.
 - Gaskets are brittle, hard, worn out or otherwise damaged. Replace damaged gaskets, O-rings.

13.6 CRANKSHAFT

Symptom: UNUSUAL ENGINE NOISE AND/OR VIBRATION

1. Check noise coming from crankshaft area.
 - Crankshaft plain bearings are damaged. Replace crankshaft plain bearings.
 - Connecting rod plain bearings are damaged. Replace connecting rod plain bearings.
 - Magnetorotor got loose. Replace damaged components and retighten rotor retaining screw with recommended torque (refer to MAGNETO SYSTEM).

13.7 GEARBOX

Symptom: UNUSUAL GEARBOX NOISE AND/OR VIBRATION

1. Check oil level in gearbox.
 - Oil leakage from gearbox. Replace damaged gasket(s) and/or oil seal(s), torque screws and refill with oil up to specified level (refer to TECHNICAL SPECIFICATIONS and GEARBOX)
2. Check bearings in the gearbox for free movement.
 - Bearing(s) do(es) not move freely. Replace bearing(s)
3. Check for knocking noise.
 - Tooth of gears are damaged and/or worn. Replace respective gears.

Symptom: GEAR INDICATION FAILS.

1. Check contact screws on gear housing center.
 - Check contact screw outside for contamination and wetness. Clean contact screw and screw for wiring harness.
 - Contact(s) is (are) corroded and/or contact screw for wiring harness got loose. Clean contact surface and retighten contact screw(s) with recommended torque.
 - Wiring harness has broken cables. Replace wiring harness.
 - Shifting indicator switch(es) pin(s) is (are) worn and/or damaged. Replace shifting indicator switch(es).

Symptom: GEAR(S) IS (ARE) HARD TO SHIFT

1. Check shift shaft splines and/or shift forks for wear and/or damages.
 - Shift shaft is worn out and/or shows damaged splines. Replace shift shaft.
 - Shift drum track(s) and/or splines is (are) worn out or damaged. Replace shift drum and damaged part(s).
 - Shift fork(s) is (are) worn out and/or engagement pins are damaged. Replace shift fork(s).
 - Shift fork(s) is (are) worn out and/or fork(s) is (are) damaged. Replace shift fork(s).
 - Shift gear(s) is (are) worn out. Replace shift gear(s).
 - Shifting indicator switch(es) pin(s) is (are) worn out (no rounding on top of pin). Replace shifting indicator switch(es).
2. Check engine idle speed.
 - Check throttle cable and throttle adjustment.
 - Check bypass idle valve and connectors.
3. Check CVT one way clutch on drive pulley.
 - CVT one way clutch was not lubricated correctly. Lubricate CVT one way clutch (refer to CONTINUOUSLY VARIABLE TRANSMISSION (CVT)).
 - CVT one way clutch is worn out or damaged. Replace defective part(s) (refer to CONTINUOUSLY VARIABLE TRANSMISSION (CVT)).
 - Check if friction washer at one way clutch is worn. Replace friction washer (refer to CONTINUOUSLY VARIABLE TRANSMISSION (CVT)).
4. Check transmission lever and connecting rod.
 - Ball joint and/or ball joint nut is (are) loose. Retighten or replace the ball joint.
5. Check spring on shift shaft in gearbox.
 - Broken spring. Replace the spring (refer to GEARBOX).
6. Check for any mud intrusions.
 - CVT parts dirty. Clean all CVT parts.

13.8 COUPLING UNIT

Symptom: 4 WHEEL DRIVE INDICATION FAILS

1. Check contact screw on gear housing right side for damage and/or wear.
 - Shifting indicator switch pin is worn and/or damaged. Replace shifting indicator switch.
 - Contact is corroded and/or contact screw for wiring harness got loose. Clean contact surface and retighten contact screw with recommended torque.

-Wiring harness has broken cable. Replace wiring harness.

Symptom: 4 WHEEL DRIVE DOES NOT ENGAGE OR DISENGAGE

1. Check actuator and/or actuator shifting fork for wear and/or damages.
 - Check if selector works properly. If so, check actuator.
 - If selector is out of specifications, check wires, connectors and/or replace selector.
 - Actuator shifting fork is worn out and/or damaged. Replace shifting fork of actuator.
 - Check function of actuator. Replace if actuator is not turning, refer to GEARBOX.
2. Check shifting sleeve splines and/or shifting fork for wear and/or damages.
 - Check sleeve shows damaged splines. Replace shifting sleeve (refer to GEARBOX).
 - Shifting fork is worn out and/or engagement pin is damaged. Replace shifting fork.

13.9 CVT

Symptom: UNUSUAL ACCELERATION BEHAVIOR

1. Check drive belt condition.
 - Belt is too narrow (drive belt engagement is higher in drive pulley). Replace belt if width is less than specified.
2. Check lever condition on drive pulley sliding sheave and/or roller(s) on governor cup.
 - Lever(s) on drive pulley sliding sheave is (are) worn and/or damaged. Replace all levers at the same time (lever kit).
 - Roller(s) is (are) worn and/or damaged. Replace governor cup assembly.
3. Check drive/driven pulley sliding sheave for free axial movement.
 - Sliding sheave is stuck. Replace damaged part(s).
4. Check condition of drive/driven pulley spring.
 - Drive pulley spring tension is too smooth and/or damaged. Replace spring.
 - Driven pulley spring tension is too stiff. Replace spring.
5. Check if cam of driven pulley is worn.
 - Replace if out of specifications.
6. Check condition of fixed and sliding sheaves (drive and driven pulley).
 - Check surface of fixed and sliding sheaves (drive and driven pulley) for grooves or other damages.
7. Check valve adjustment.
 - Intake and/or exhaust valves are not adjusted correctly. Adjust valves.
8. Check engine condition.
 - Low engine compression.
9. Check ignition condition.
 - Faulty spark plug. Install new spark plug(s).
10. Check differentials operation.
 - Vehicle on Neutral is hard to move. Repair or replace defective part(s).

Symptom: ENGINE MAXIMUM RPM IS TOO HIGH AND VEHICLE TOP SPEED IS NOT REACHED.

1. Check drive/driven pulley area for contamination and/or water intrusion.
 - CVT area is contaminated with water, dirt or oil. Clean CVT system and replace damaged part(s).
2. Check drive/driven pulley spring tension.
 - Drive pulley spring tension is too stiff. Replace spring.
 - Driven pulley spring tension is too smooth and/or damaged. Replace spring.

Symptom: DRIVE PULLEY NOISE IN IDLE SPEED

1. Check slider shoes (drive pulley).
 - Worn slider shoes (increased clearance between governor cup and drive pulley sliding sheave). Replace all slider shoes at the same time (slider shoes kit).
2. Check driven pulley sliding mechanism (between driven pulley outer and inner sheave).
 - Mechanism is stuck and/or damaged. Replace driven pulley assembly.
3. Check roller(s) and/or levers for wear (located on sliding sheave of drive pulley).
 - Roller(s) on governor cup is (are) worn out and/or damaged. Replace governor cup assembly.
 - Lever(s) on drive pulley sliding sheave is (are) worn out and/or damaged. Replace all levers at the same time (lever kit).
4. Check drive pulley screw for torque.
 - Loose screw. Retighten screw with recommended torque.
5. Check one-way clutch condition on drive pulley sliding sheave.
 - Bearing(s) do(es) not move freely. Replace damaged part(s) and lubricate inside of one-way clutch.
 - Spring sleeve(s) inside one-way clutch is (are) worn out. Replace both sleeves and springs and lubricate inside of one-way clutch.
 - Spring(s) inside one-way clutch is (are) worn out. Replace both pins and springs and lubricate inside of one-way clutch.

Symptom: DRIVE PULLEY NOISE WHEN ACCELERATING/DECELERATING

1. Check if belt runs in dry condition.
 - Drive pulley area is wet/contaminated due to water/dirt intrusion. Clean driven pulley area and/or drain water out of CVT cover.
2. Check drive/driven pulley screw for torque.
 - Loose screw on drive pulley. Retighten screw with recommended torque.
3. Check cam and driven pulley fixed sheave for wear.
 - Cam and/or drive pulley fixed sheave out of wear limit and/or damaged. Replace damaged part(s).

4. Check torque gear fixed in driven pulley sliding sheave for wear.
Torque gear out of wear limit and/or damaged. Replace torque gear).
5. Check for foreign particles in CVT area (stones, dirt, etc.).
Small particles damaged belt and/or pulley surface(s). clean system and replace damaged parts.

Symptom: VIBRATIONS ORIGINATING FROM DRIVE PULLEY

1. Check tightening torque of drive pulley screw.
Moving sliding sheave. Retighten screw.
2. Check fixed sheave bushings.
Excessive gap between bushings and fixed sheave shaft, thus restraining sliding sheave movements. Replace fixed sheave assembly.
3. Check if slider shoes are present and/or placed in correct position.
Slider shoe(s) is (are) missing and/or damaged. Replace all slider shoes at the same time (slider shoes kit).

Symptom: VIBRATIONS ORIGINATING FROM DRIVEN PULLEY

1. Check fixed and sliding sheave bushings on driven pulley.
Excessive gap between bushings and CVT shaft, thus restraining sliding sheave movements. Replace fixed and/or sliding sheave of driven pulley, polish CVT shaft area with fine emery cloth and wipe clean with a cloth.

Symptom: PULLEYS DO NOT DOWN/UP SHIFT PROPERLY.

1. Check drive pulley bushings (cleanliness, wear, etc.)
-Check items 1 and 2 of UNUSUAL ACCELERATION BEHAVIOR.
-Bushings stick to fixed sheave pulley shaft. Clean or replace.
-Spring seat sticks to sliding sheave pulley bushing. Clean system and/or replace sliding sheave pulley.
-One-way clutch does not operate properly. Clean system and/or replace damaged part(s).
2. Check driven pulley spring tension.
-Driven pulley spring tension is too weak or broken. Replace.
-Driven pulley cam is worn or damaged. Replace.

Symptom: BELT GLAZED EXCESSIVELY OR HAVING BAKED APPEARANCE

1. Check if CVT air intake and/or outlet is clogged.
-CVT area heats up due to contamination. Clean air intake and/or outlet from contamination.
-Fans located on drive pulley is worn or damaged. Replace.
2. Check if pulley sheaves are clean.
-Oil on pulley surfaces. Clean pulley sheaves and replace belt.
-Water intrusion in CVT area. Find root cause and repair. Drain water and replace belt.

Symptom: BELT WORN EXCESSIVELY IN TOP WIDTH.

1. Check drive belt width.
-Considerable wear. Replace belt if narrower than specified (refer to CONTINUOUSLY VARIABLE TRANSMISSION (CVT) OR TECHNICAL SPECIFICATIONS).
2. Check driver belt identification number.
Wrong type of belt. Replace belt with an appropriate drive belt.
3. Check for localized belt wear caused by belt slippage.
Localized wear. Replace belt.

Symptom: BELT DISINTEGRATION.

1. Check drive belt lifetime is exceeded.
Clean CVT system and rebuild with a new drive belt.
2. Check drive belt identification number.
Excessive belt speed. Using unspecified type of belt. Replace belt with proper type of belt.
3. Check if pulley sheaves are clean.
-Oil on pulley surfaces. Clean pulley surfaces with fine emery cloth and wipe clean using pulley flange cleaner and a cloth.
-Drive/driven pulley sheaves are damaged through stones inside CVT area. Clean pulley surfaces with fine emery cloth, wipe clean with a cloth or replace drive/driven pulley sheaves and belt.

Symptom: BACK BETWEEN COGS

1. Check drive belt condition.
-Considerable use, belt wearing out. Replace.
-Brittle belt condition through aging. Replace belt.

13.10 ENGINE GENERALSymptom: ENGINE CRANKS BUT FAIL TO START

1. Check if spark plug connectors fit on spark plugs (refer to IGNITION SYSTEM).
2. Check spark plugs.
Define spark plugs (no spark) or wrong spark plug gap. Readjust gap and clean spark plugs or replace.
3. Check for fuel on spark plugs.
Flooded engine (spark plugs wet when removed). Activate engine drowned mode and crank engine with rags over the spark plug holes.
4. Check battery voltage.
Battery is discharged and starter works not properly. Charge battery.
5. Check fuel level in fuel tank and fuel pressure. Ensure fuel pump was not disabled.

- Low or no fuel pressure. Replace defective part(s).
- 6. Check fuel injectors.
 - Plugged or faulty injector(s). Replace defective part(s).
- 7. Check idle bypass valve.
 - Stuck or defective.
- 8. Check encoder wheel.
 - Bent tooth. Refer to MAGNETO SYSTEM.
- 9. Check engine compression.
 - Insufficient engine compression. Replace defective part(s).
- 10. Check fault codes in DIAGNOSTIC TOOL system.
 - Check if actuator(s) is/are defective. Replace defective part(s) (refer to COMPONENT INSPECTION AND ADJUSTMENT).

Symptom: ENGINE DOES NOT START

- 1. Electrical problem.
 - Determine if the electrical system works correctly (fuse(s), battery, wiring harness, etc.). Refer to IGNITION SYSTEM.
- 2. Problem with fuel system (carburetor, fuel pump, hoses, etc.).
 - Clean, inspect, repair or replace defective parts.
- 3. Check engine compression.
 - Insufficient engine compression. Replace defective parts.
 - Valve seat worn and/or damaged. Repair by performing valve guide procedure (refer to CYLINDER AND HEAD). Readjust valve clearance.
- 4. Internal engine problem.
 - Overhaul engine to find defective parts. Refer to the appropriate section in ENGINE.

Symptom: ENGINE HARD TO START

- 1. Check idle bypass valve.
 - Stuck or defective. Refer to ENGINE MANAGEMENT.
- 2. Check closed throttle and idle actuator with DIAGNOSTIC TOOL.
 - Wrong TPS zero setting/idle bypass valve reset. Refer to ENGINE MANAGEMENT.
- 3. Check engine compression.
 - Wrong adjustment (likely too tight). Refer to ENGINE MANAGEMENT.
- 4. Check engine compression.
 - Insufficient engine compression. Replace defective part(s) refer to LEAK TEST.
- 5. Verify spark plug condition.
 - Defective, improperly set, worn out, fouled. Identify source of problem and correct. Replace.
- 6. Check fuel level in fuel tank and fuel pressure.
 - Low or no fuel pressure. Replace defective part(s) refer to FUEL TANK AND FUEL PUMP.
- 7. Check CAPS (camshaft position sensor).
 - Defective sensor/wiring. Refer to ENGINE MANAGEMENT.

Symptom: ENGINE SUDDENLY TURNS OFF

- 1. Perform engine leak test.
 - Damaged head gasket and/or seal and/or leaking inlet/exhaust valve(s). replace and/or repair defective parts.
- 2. Check spark plugs condition and/or gap.
 - Fouled spark plugs or wrong spark plug gap. Readjust gap and clean spark plugs or replace.
- 3. Piston seizure.
 - Spark plugs heat range is too hot. Install spark plugs with appropriate heat range (refer to TECHNICAL SPECIFICATIONS).
 - Compression ratio is too high. Install genuine parts.
 - Poor oil quality. Use recommended oil.
 - Leaks at air intake manifold (engine gets too lean). Retighten screws or replace air intake manifold gasket.
 - Snow/water intrusion through intake system into combustion chamber. Clean intake system and replace defective part(s).
- 4. Melted and/or perforated piston dome; melted section at ring end gap.
 - Spark plugs heat range is too hot. Install recommended spark plugs (refer to TECHNICAL SPECIFICATIONS).
 - Coolant less than recommended level (engine gets too hot). Repair cooling circuit and/or refill with recommended liquid.
 - Poor quality and/or wrong fuel. Clean from contamination and use appropriate fuel (refer to TECHNICAL SPECIFICATIONS).
- 5. Piston color is dark due to seizure on intake and exhaust side.
 - Cooling system leaks and lowers coolant level. Tighten clamps or replace defective parts. Add antifreeze in cooling system until appropriate level reached. Replace damaged parts.
- 6. Cracked or broken piston.
 - Cracked or broken piston due to excessive piston/cylinder clearance or engine overheating. Replace piston. Check piston/cylinder clearance (refer to CYLINDER AND HEAD).
- 7. Check piston rings and cylinder surface for grooves.
 - Poor oil quality. Use recommended oil.

- Contamination through engine intake. Replace defective part(s) and use new air filter.
- 8. Check crankshaft, rocker arms movement.
 - Oil pump failure due to lack of oil. Repair and replace defective parts and use new recommended oil.
 - Oil contamination due to clogged oil filter/oil strainer. Replace oil and oil filter at the same time, replace defective part(s).
- 9. Check valve springs exhaust/intake.
 - Broken valve spring damages the cylinder head, valve(s), rocker arm(s), piston, piston rings and connecting rod. Replace defective part(s).
- 10. Check if fuel supply is sufficient.
 - Low fuel level.
 - Clogged fuel filter or fuel injector filter.
 - Fuel line is contaminated and/or bent. Clean and/or replace defective part(s).

Symptom: ENGINE BACKFIRES

1. Check spark plugs.
 - Carbon accumulation caused by defective spark plugs. Replace spark plugs.
2. Check leakage on intake manifold.
 - Air leak on intake system. Retighten screws and/or replace intake manifold gasket.
3. Check exhaust air leaking.
 - Exhaust gasket is leaking. Retighten screws and/or replace exhaust gasket.
4. Check intake valve(s) for leaking.
 - Intake valve(s) is (are) leaking. Repair or replace valve(s).
5. Check if fuel supply is sufficient.
 - Fuel line is contaminated and/or bent (engine gets lean). Clean and/or replace defective part(s).
6. Check engine ground.
 - Poor engine ground. Clean.

Symptom: ENGINE DOES NOT OFFER MAXIMUM POWER AND/OR DOES NOT REACH MAXIMUM OPERATING RPM

1. Check spark plugs condition and/or gap.
 - Fouled spark plugs or wrong spark plug gap. Readjust gap and clean spark plugs or replace.
2. Check spark plugs type.
 - Improper spark plugs heat range. Install recommended spark plugs (refer to TECHNICAL SPECIFICATIONS).
3. Perform engine leak test.
 - Damaged head gasket and/or seal and/or leaking intake/exhaust valve(s). replace and/or repair defective parts.
4. Check for water in fuel (wrong fuel).
 - There is water in fuel or wrong fuel. Drain fuel system, search for leakage and refill it with appropriate fuel.
5. Check engine compression.
 - Worn piston(s) and/or piston ring(s). Replace defective part(s).
6. Check fuel pressure.
 - Low fuel pressure. Perform fuel pressure test (refer to FUEL SYSTEM).
7. Check air intake system.
 - Air filter is clogged due to contamination. Replace air filter.
8. Check if EMS (engine management system) is in limp home mode. Check fault codes in DIAGNOSTIC TOOL system.
 - Check if electrical actuator(s) is/are defective. Replace defective part(s).
9. Check drive belt.
 - Worn. Replace belt if its width is less than specified.

Symptom: HIGH ENGINE OPERATING TEMPERATURE

1. Check if cooling system shows any failure (see COOLING SYSTEM).
 - System is leaking. Repair and/or replace damaged part(s).
2. Check function of lubrication system (see LUBRICATION SYSTEM).
 - Lubrication is not working properly. Repair and/or replace damaged part(s).
3. Check condition and heat range of spark plugs.
 - Melted spark plug tip or inadequate heat range. Replace.
4. Check air leakage on engine intake.
 - Leakage causes overheating. Replace/repair damaged part(s).
5. Check air inlet and outlet of the CVT cover.
 - Air circulation is clogged (overheating). Clean air circulation from contamination.
 - Drive belt worn and/or damaged. Replace belt with an appropriate drive belt (refer to TECHNICAL SPECIFICATIONS).

13.11 HEATER SYSTEMSymptom: LACKING HEATING

1. Engine running time is too short, and the coolant is too cool.
 - Engine running at least 10 minutes.
2. Check air inlet filter
 - Air filter is clogged due to contamination. Clean air filter.

3. Temperature switch is not working.
Replace a new switch.
4. Temperature controlled solenoid valve is clogged or not working.
Replace a new solenoid valve.
5. Check coolant level.
Coolant level lower than recommended. Refill (refer to cooling system).

Symptom: NO WIND AT THE OUTLET

1. Air outlet hose loose or damaged.
Connect or replace new hose.
2. Temperature switch is not working.
Replace a new switch.
3. Electrical problem.
Determine if the electrical system works correctly (fuse(s), battery, wiring harness, etc.).

13.12 HVAC SYSTEM

Symptom: LACKING HEATING

1. Engine running time is too short, and the coolant is too cool.
-Engine running at least 10 minutes.
2. Check air inlet filter
-Air filter is clogged due to contamination. Clean air filter.
3. Temperature switch is not working.
-Replace a new switch.
4. Temperature controlled solenoid valve is clogged or not working.
-Replace a new solenoid valve.
5. Check coolant level.
-Coolant level lower than recommended. Refill (refer to cooling system).

Symptom: LACKING COOLING

1. Check air inlet filter.
-Air filter is clogged due to contamination. Clean air filter.
2. Check condenser.
-Condenser fins obstructed, hard air cooling. Clean condenser fins.
3. Check cooling fan and connection (must all fan can work).
-Fan motor faulty. Replace.
-Wire harness is brittle or hard (no connection). Replace.
4. Check AC compressor.
-Compressor is not working. Replace.
-Compressor belt loose and/or worn. Adjust or Replace belt with an appropriate drive belt.
5. Refrigerant is shortage.
-Check the air bubbles from sight glass in the pipe between condenser and evaporator. If there are a lot of air bubbles all the time when the compressor is running. Refill refrigerant.
6. Heating solenoid valve can not close completely.
-Solenoid valve is damaged. Replace

Symptom: AC COMPRESSOR DOES NOT START

1. Refrigerant is serious shortage.
-There is NO pressure in the pipe. Refill refrigerant.
2. Temperature switch is not working.

- Replace a new switch.
- 3. Temperature controller system is damaged.
 - Replace a new sensor or/and controller.
- 4. The electromagnetic clutch of compressor is not working.
 - Replace a new electromagnetic clutch.
- 5. Internal AC compressor problem.
 - Replace a new AC compressor.

Symptom: NO WIND AT THE OUTLET

- 4. Air outlet hose loose or damaged.
 - Connect or replace new hose.
- 5. Temperature switch is not working.
 - Replace a new switch.
- 6. Electrical problem.
 - Determine if the electrical system works correctly (fuse(s), battery, wiring harness, etc.).
- 7. Air blower assy is not working.
 - Replace a new blower.

Symptom: HVAC SYSTEM NOISE

- 1. AC compressor drive belt is too loose or tight.
 - Adjust the belt degree of tightness.
- 2. Compressor belt is worn.
 - Replace belt with an appropriate drive belt.
- 3. Air blower assy is damaged.
 - Replace a new blower.
- 4. Internal AC compressor problem.
 - Replace a new AC compressor.

14.SPECIFICATIONS

Item		Parameter
Dimensions		
Overall length		3095mm
Overall width		1700mm
Overall height		2090mm
Wheelbase		2145mm
Tread		1340mm (Front)/1293mm (Rear)
Min. Ground clearance		310mm
Cargo bed dimensions		920*1260*285mm
Min. Turning radius		6m
Max Speed		100km/h
Engine		
Type		Two-cylinder, 4-stroke, SOHC, water cooling,
Number of valves		8(mechanical adjustment)
Cylinder diameter		91mm
Piston stroke		75 mm
Compression ratio		10.5:1
Displacement		976cm ³
Maximum power		53kw/6500rpm
Maximum torque		85Nm/5500rpm
Idle speed		1250rpm
Lubrication	Type	Wet tank lubrication, oil filters can be changed
	Oil pressure	0.18-0.3 MPa at 1250 rpm
	Type of oil	SAE10W-40 SJ
	Oil quantity	2200ml
	Replacement of capacity	1850ml
Fuel	Type	Unleaded gasoline only 93# or higher
	Fuel pressure	350 KPa
	Fuel tank capacity	48L
Valve clearance	Intake	0.05 to 0.09mm
	Exhaust	0.10 to 0.15mm
Spark plug	Type/manufacturer	DCPR8E / NGK
	Gap	0.7 to 0.9mm
Transmission type		CVT (Continuously Variable Transmission) + Gearbox
Continuously variable ratio		0.71 to 3.1
Drive belt width	Service limit	30.00mm
Gearbox type		Dual range(H/L) with park, neutral and reverse
Gearbox oil capacity		1500mL (GL-5 75W140)

Gear ratio	H	3.183
	L	7.841
	R	6.919
Capacity of cooling liquid	Type	Ethyl glycol/water mix (-35°C)
	Maximum load	7100mL
	Capacity of water tank	800ml
Cooling liquid temperature thermostat	Valve opening	76°C
	Fan opening	82°C
Capacity of Refrigerant		450g(R134a-US), 450g(R1234yf-EU),
Tire		
Type		Tubeless
Pressure		97 to 110 KPa
Size Front		AT27×9–14/30x10-14(Rim14x7)
Size Rear		AT27×11–14/30x10-14(Rim14x8)
Brake		
System		Front and rear unified
Type Front		Dual disc brake
Type Rear		Dual disc brake
Operation		Foot/Electrical Parking Brake
Brake fluid type		265ml (DOT 4)

Suspension and shock absorber			
Front suspension		Double A-arm independent	
Rear suspension		Double A-arm independent	
Front shock absorber		Coil spring/Oil damper/Airbag shock absorption	
Front shock absorber travel		254mm	
Rear shock absorber		Coil spring/Oil damper/Airbag shock absorption	
Rear shock absorber travel		245mm	
Drive train			
Front differential		Shaft driven/single auto-lock differential	
Front differential ratio		3.6:1	
Front differential oil capacity		280mL (GL-5 80W90)	
Rear axle		Shaft driven/single differential	
Rear axle ratio		3.6:1	
Electrical			
Ignition system		EFI	
Battery		Type	Maintenance Free
		Voltage	12V
		capacity	45AH
Fuses	F1	Ignition Switch	20A
	F2	USB	20A
	F3	EPS	40A
	F4	Fan	40A
	F5	Light Power	20A
	F6	Wiper Motor	20A
	F7	2WD/4WD Switch	10A
	F8	Horn	10A
	F9	Top Light	15A
	F10	EFI	15A
	F11	EPB	30A
	F12	Oil Cooler Fan	10A
Relays	RY1	EFI System Relay	-
	RY2	Light Relay	-
	RY3	Top Light Relay	-
	RY4	Wiper Power Relay	-
	RY5	Fuel Pump Relay	-
	RY6	2WD/4WD Switch Relay 1	-
	RY7	2WD/4WD Switch Relay 2	
	RY8	Oil Cooler Fan relay	
	RY9	Low Headlight Relay	-
	RY10	High Headlight Relay	-
	RY11	Horn Relay	-
	RY12	AC Relay	-
	RY13	Rear left trailer Relay	
	RY14	Rear right trailer Relay	



Wire diagram